

0CV10-M55100EN

P R E F A C E

1. This Parts Catalog carries all parts incorporated in YANMAR Model 4TNE94 - ACG engine manufactured since December, 1997.
2. Each illustration corresponds to the parts list on the following page.
3. When ordering parts, clearly write down the engine model and serial number, as well as the name and number of each part in your order sheet. This will help insure reliable delivery of the parts you have ordered.

Directions for the Parts Catalog.

1. This Parts Catalog shows both standard and optional parts.
2. Parts may change without prior notice.
3. The following is an example of the Parts Catalog format.

REF.	LEV.	PARTS NO.	DESCRIPTION	Q'TY						I	R
				(A)	(B)	(C)	(D)	(E)	(F)		
1	1	729595-51390	FUEL INJECTION PUMP	1	1	1	1	1			1
1-1	1	729595-51391	FUEL INJECTION PUMP	1	1	1	1	1		N	1
		(A=E00185) (B=E00200)									
3	2	26022-060162	SCREW M 6X 16	9	9	9	9	9			
3-1	2	26022-060162	SCREW M 6X 16	4	4	4	4	4		K	
		(A=E00156) (B=E00156) (C=E00156) (D=E00156) (E=E00156)									
4	2	129470-51040	CAMSHAFT	1	1	1	1	1			
5	2	122710-51050	BEARING, ROLLER	2	2	2	2	2			
6	2	129470-51060	RETAINER	1	1	1	1	1			

Remarks
(1) BOOST COMPEMSATOR TYPE. OPTIONAL PART, TO E00155,(4JH-DT, 4JH-DTZ

① Ref. No.

The Ref. No. listed may not be in accordance with the illustration Ref. No.

(Ex.) Illustration No. 1 List Ref No. 1 (Before change) → 1-1 (After change)

For interchangeable symbols N, R and K, illustrations for new parts may be abbreviated.

② Lev. (Level)

Level indication

The numbers below indicate the level of relativity towards the main part.

1 ----- Main parts (Assembly parts)

2 ----- Sub component included in " 1 ".

3 ----- Sub component included in " 2 ".

Note) Parts that are not for sale are partially illustrated but not listed.

③ Interchangeability Symbol

When a part change takes place, one of the following interchangeability symbols is indicated beside the part.

Symbol	Interchangeability	Contents note
N	Old $\begin{matrix} \leftarrow \text{Yes} \\ \text{No} \rightarrow \end{matrix}$ New	New Part is interchangeable for Old Part but Old Part is not interchangeable for New Part.
Q	Old $\begin{matrix} \leftarrow \text{No} \\ \text{Yes} \rightarrow \end{matrix}$ New	New Part is not interchangeable for Old Part but Old Part is interchangeable for New Part.
R	Old $\begin{matrix} \leftarrow \text{Yes} \\ \text{Yes} \rightarrow \end{matrix}$ New	New/ Old Parts are both interchangeable.
S	Old $\begin{matrix} \leftarrow \text{No} \\ \text{No} \rightarrow \end{matrix}$ New	New/ Old Parts are both not interchangeable.
W		Part newly added.
Z		Part discontinued.
F		Not interchangeable by a single part but interchangeable together with related parts.
K		Changes only for used parts quantities.

④ Effective Machine No.

When a part changes, the effective Machine No. will be indicated in the (A)-(F) column.

Product Symbol	Product No.	Product Symbol	Product No.
C	Clutch No. Compressor No.	F	Machine No. (Agricultural Equip.)
D	Drive No.	M	Machine No.
E	Engine No.		

Note 1) A date may follow the symbol. (Ex.) 1996.01

Note 2) "XXXXX" and "ZZZZZ" are for parts that could not be predicted or for engine models that could not be identified.

Note 3) (A=E00185) is the E (Engine Serial Number) for the column (A) model (in this case 4JH-DT) after the parts design change.

⑤ Remarks

Figures or alphabets (symbols) are entered in the remarks column.

The comments (remarks) on parts that are indicated at the bottom of the illustration are the same symbols as those stated above.

Fig. No. Fig. Name

ENGINE SECTION (4TNE94-ACG)

1. CYLINDER BLOCK
2. GEAR HOUSING
3. FLYWHEEL HOUSING & OIL SUMP
4. CYLINDER HEAD & BONNET
5. SUCTION MANIFOLD
6. EXHAUST MANIFOLD
7. CAMSHAFT & DRIVING GEAR
8. CRANKSHAFT & PISTON
9. LUB.OIL SYSTEM
10. COOLING WATER SYSTEM
11. FUEL INJECTION PUMP
12. GOVERNOR
13. FEED PUMP
14. FUEL INJECTION VALVE
15. FUEL LINE
16. ENGINE STOP DEVICE
17. STARTING MOTOR
18. GENERATOR
19. GASKET SET

Fig. No. Fig. Name



2. GEAR HOUSING

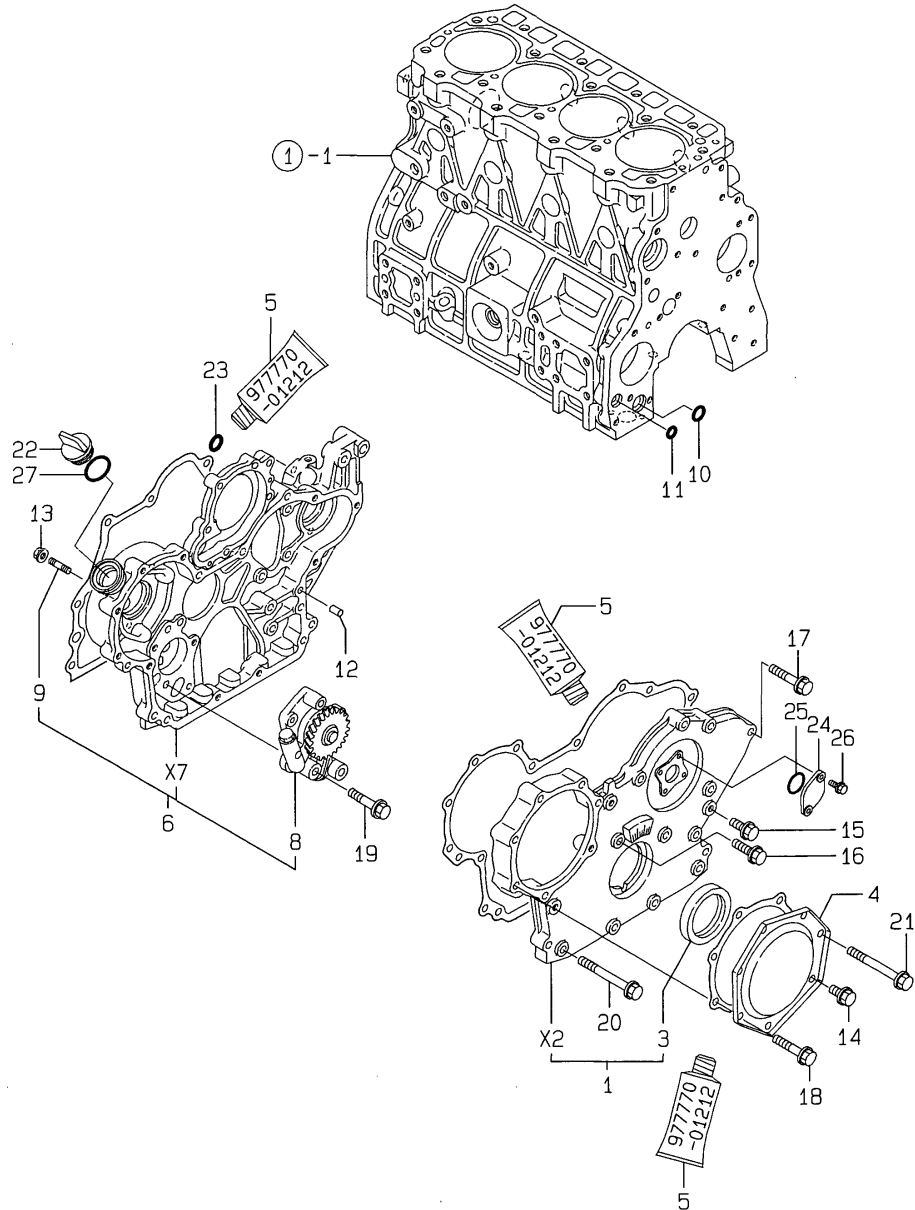

(A)=4TNE94-ACG

(B)=

(C)=

(D)=

(E)=

(F)=

No.	Lev.	Parts No.	Description	Q'ty						I	R
				(A)	(B)	(C)	(D)	(E)	(F)		
1	1	729900-01570	COVER ASSY,GEAR CASE	1							
3	2	129900-01780	SEAL, OIL	1							
4	1	129900-01740	COVER	1							
5	1	977770-01212	GASKET, LIQUID	1							1
6	1	129900-01820	CASE ASSY, GEAR	1							
8	2	129900-32000	PUMP ASSY, OIL	1							
9	2	26216-100302	STUD, M10X 30	4							
10	1	129900-32030	O-RING, P20	1							
11	1	129900-32040	O-RING, P14	1							
12	1	22312-080160	PIN, PARALLEL M8X16	4							
13	1	26366-100002	NUT, M10	4							
14	1	26106-080162	BOLT, M8X 16 PLATED	1							
15	1	26106-080202	BOLT, M8X 20 PLATED	3							
16	1	26106-080302	BOLT, M8X 30 PLATED	1							
17	1	26106-080402	BOLT, M8X 40 PLATED	5							
18	1	26106-080402	BOLT, M8X 40 PLATED	5							
19	1	26106-080452	BOLT, M8X 45 PLATED	3							
20	1	26106-080702	BOLT, M8X 70 PLATED	6							
21	1	26106-080702	BOLT, M8X 70 PLATED	1							
22	1	124160-01751	COVER, FILLER	1							
23	1	24311-000070	O-RING, 1AP7.0	1							
24	1	121023-01550	COVER	1							
25	1	24341-000240	O-RING, 1AS24.0	1							
26	1	26106-060162	BOLT, M6X 16 PLATED	2							
27	1	24311-000320	O-RING, 1AP32.0	1							

Remarks

(1) OPTIONAL PART.

N:Old $\xrightarrow{\text{Yes}}$ New, Q:Old $\xrightarrow{\text{No}}$ New, R:Old $\xrightarrow{\text{Yes}}$ New, S:Old $\xrightarrow{\text{No}}$ New, W:Add, Z:Discontinued, F:Interchangeable by set, K:Q'ty Change

3, FLYWHEEL HOUSING & OIL SUMP

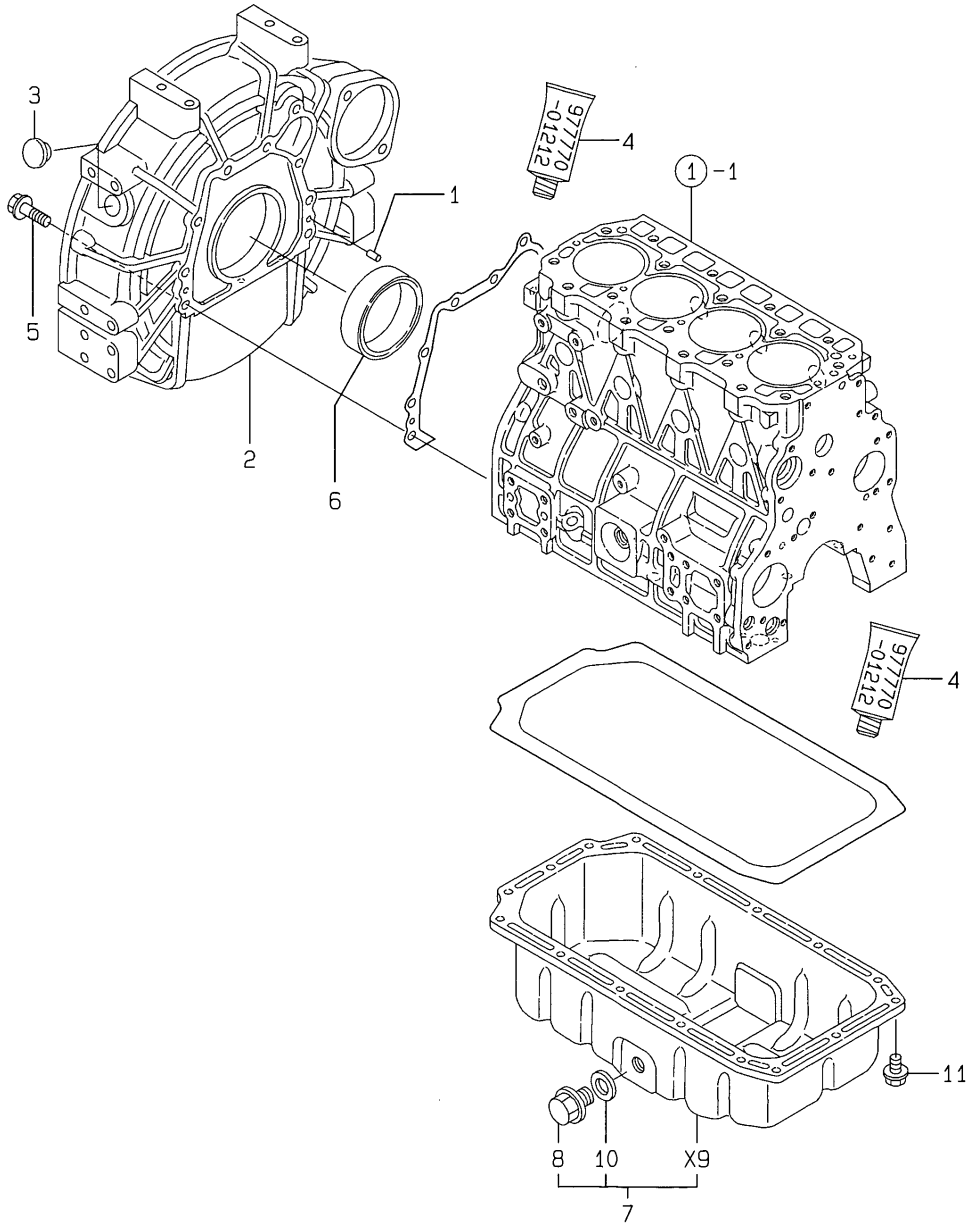

(A)=4TNE94-ACG

(B)=

(C)=

(D)=

(E)=

(F)=

No.	Lev.	Parts No.	Description	Q'ty						I	R
				(A)	(B)	(C)	(D)	(E)	(F)		
1	1	129100-01580	PIN, M8X16	2							
2	1	129915-01610	HOUSING, FLYWHEEL	1							
3	1	119000-01840	PLUG, RUBBER	1							
4	1	977770-01212	GASKET, LIQUID	1							1
5	1	26206-100352	BOLT, M10X 35 PLATED	9							
6	1	124411-01780	SEAL, HTC95X115X12	1							
7	1	129902-01710	SUMP ASSY, OIL	1							
8	2	119640-01640	PLUG, DRAIN M22	1							
10	2	22190-220002	WASHER, SEAL 22	1							
11	1	26106-080122	BOLT, M8X 12 PLATED	21							

Remarks

(1) OPTIONAL PART.

N:Old $\xrightarrow{\text{Yes}}$ New, Q:Old $\xrightarrow{\text{No}}$ New, R:Old $\xrightarrow{\text{Yes}}$ New, S:Old $\xrightarrow{\text{No}}$ New, W:Add, Z:Discontinued, F:Interchangeable by set, K:Q'ty Change

Copyright (C) YANMAR CO., LTD. All Rights Reserved.

4, CYLINDER HEAD & BONNET

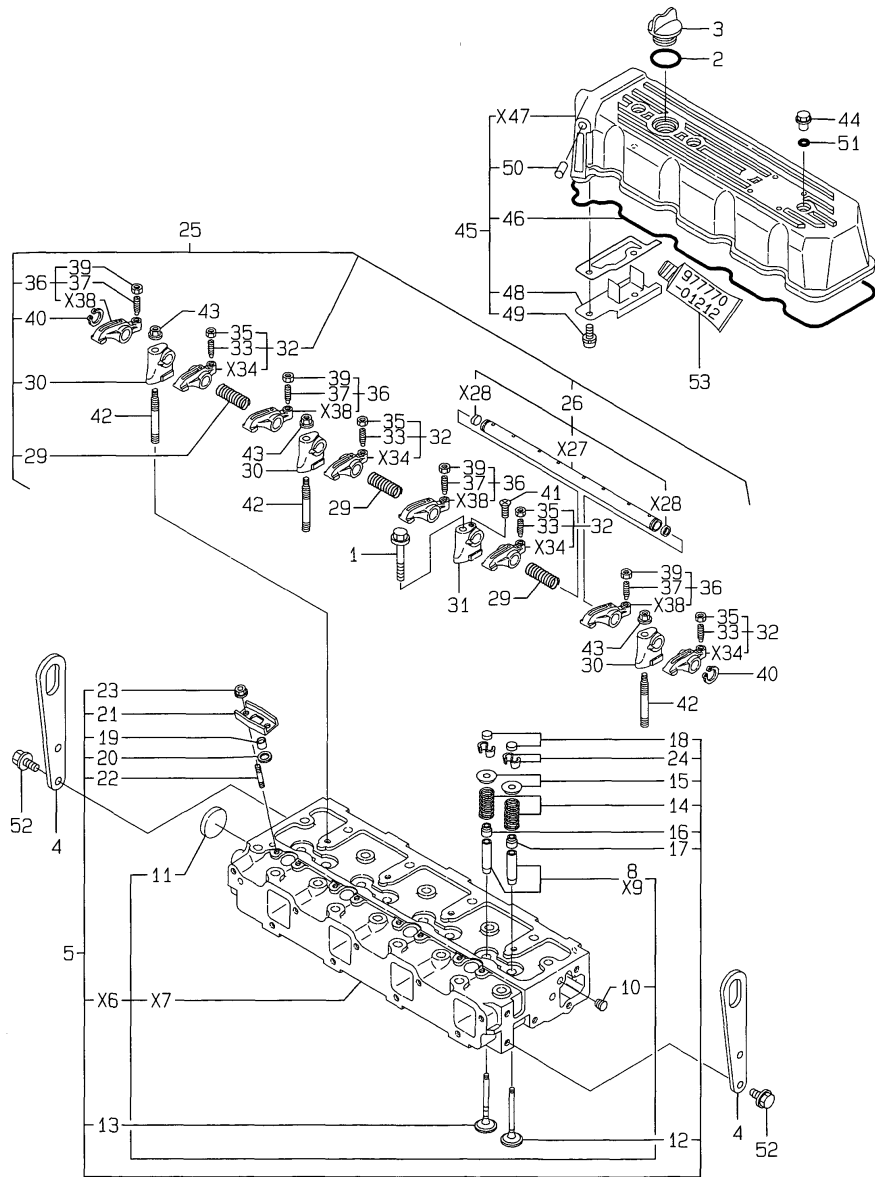

x-MARK PARTS: NOT SOLD SEPARATELY.

Remarks
 (1) REPAIR PART.
 (2) OPTIONAL PART.

(A)=4TNE94-ACG
 (B)=
 (C)=

(D)=
 (E)=
 (F)=

No.	Lev.	Parts No.	Description	Q'ty						I	R
				(A)	(B)	(C)	(D)	(E)	(F)		
1	1	26106-100652	BOLT, M10X 65 PLATED	1							
2	1	24311-000320	O-RING, 1AP32.0	1							
3	1	124160-01751	COVER, FILLER	1							
4	1	129900-07900	LIFTER	2							
5	1	729900-11100	HEAD ASSY, CYLINDER	1							
8	3	129150-11810	GUIDE, VALVE	8							1
10	3	23871-005000	PLUG, R005	1							
11	3	27241-400000	PLUG, 40	1							
12	2	129900-11100	VALVE, INTAKE	4							
13	2	129900-11110	VALVE, EXHAUST	4							
14	2	129900-11120	SPRING, VALVE	8							
15	2	129795-11180	RETAINER, SPRING	8							
16	2	121400-11340	SEAL, VALVE STEM	4							
17	2	124460-11340	SEAL, VALVE STEM	4							
18	2	129150-11370	CAP, VALVE	8							
19	2	119625-11870	PROTECTOR, NOZZLE	4							
20	2	119625-11880	SEAT, NOZZLE	4							
21	2	119625-11900	RETAINER, NOZZLE	4							
22	2	26216-060202	STUD, M6X 20	8							
23	2	26366-060002	NUT, M6	8							
24	2	27310-080001	COTTER, 8	8							
25	1	129900-11200	SUPPORT ASSY, ARM	1							
26	2	129900-11240	SHAFT ASSY, ROCKER	1							
29	2	129900-11280	SPRING	3							
30	2	129900-11510	SUPPORT, ROCKER ARM	3							
31	2	129900-11520	SUPPORT, ROCKER ARM	1							
32	2	129900-11650	ARM, ROCKER	4							
33	3	129150-11230	SCREW, VALVE ADJUST	4							
35	3	129150-11750	NUT, M8	4							
36	2	129900-11660	ARM, ROCKER	4							
37	3	129150-11230	SCREW, VALVE ADJUST	4							
39	3	129150-11750	NUT, M8	4							
40	2	22242-000180	RING, 18	2							
41	2	26577-040162	SCREW, M4X16	1							
42	1	129900-11530	STUD	3							
43	1	26366-100002	NUT, M10	3							
44	1	124160-11360	KNOB	3							
45	1	129900-11370	BONNET ASSY, HEAD	1							
46	2	129900-11310	GASKET, BONNET	1							
48	2	129900-11600	PLATE, BAFFLE	1							
49	2	22857-500100	SCREW, 5X10	2							
50	2	27225-080080	PLUG, 8X 8	1							
51	1	24311-000120	O-RING, 1AP12.0	3							
52	1	26106-080162	BOLT, M8X 16 PLATED	4							
53	1	977770-01212	GASKET, LIQUID	1							2

5. SUCTION MANIFOLD

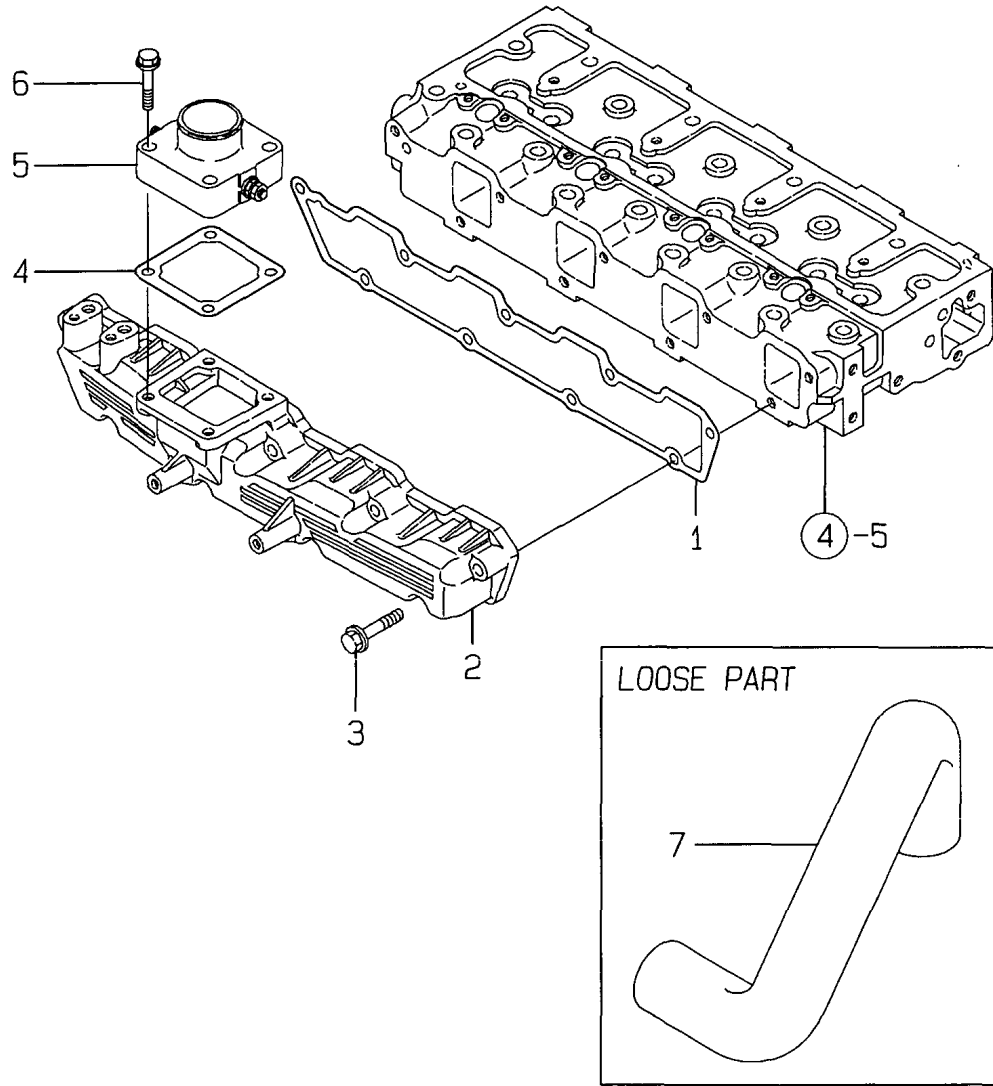

(A)=4TNE94-ACG
(B)=
(C)=

(D)=
(E)=
(F)=

No.	Lev.	Parts No.	Description	Q'ty						I	R
				(A)	(B)	(C)	(D)	(E)	(F)		
1	1	129900-12050	GASKET, MANIFOLD	1							
2	1	129900-12100	MANIFOLD, AIR INTAKE	1							
3	1	26106-080452	BOLT, M8X 45 PLATED	9							
4	1	121850-77021	GASKET	1							
5	1	129915-77050	HEATER	1							
6	1	26106-080352	BOLT, M8X 35 PLATED	4							
7	1	119140-12040	PIPE, AIR INTAKE	1							

6. EXHAUST MANIFOLD

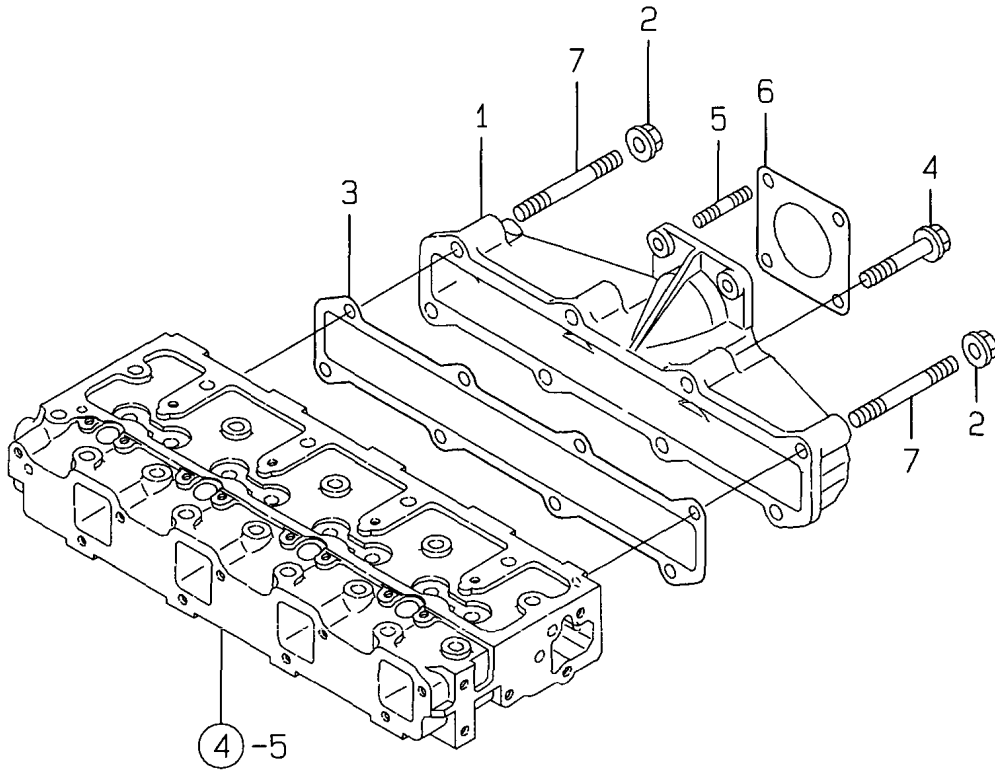

(A)=4TNE94-ACG
(B)=
(C)=

(D)=
(E)=
(F)=

No.	Lev.	Parts No.	Description	Q'ty						I	R
				(A)	(B)	(C)	(D)	(E)	(F)		
1	1	129900-13120	MANIFOLD, EXHAUST	1							
2	1	26366-080002	NUT, M8	2							
3	1	129900-13150	GASKET	1							
4	1	26106-080452	BOLT, M8X 45 PLATED	6							
5	1	119131-18320	STUD, M8X22	4							
6	1	129400-13201	GASKET, SILENCER	1							
7	1	26216-080452	STUD, M8X 45	2							

7, CAMSHAFT & DRIVING GEAR

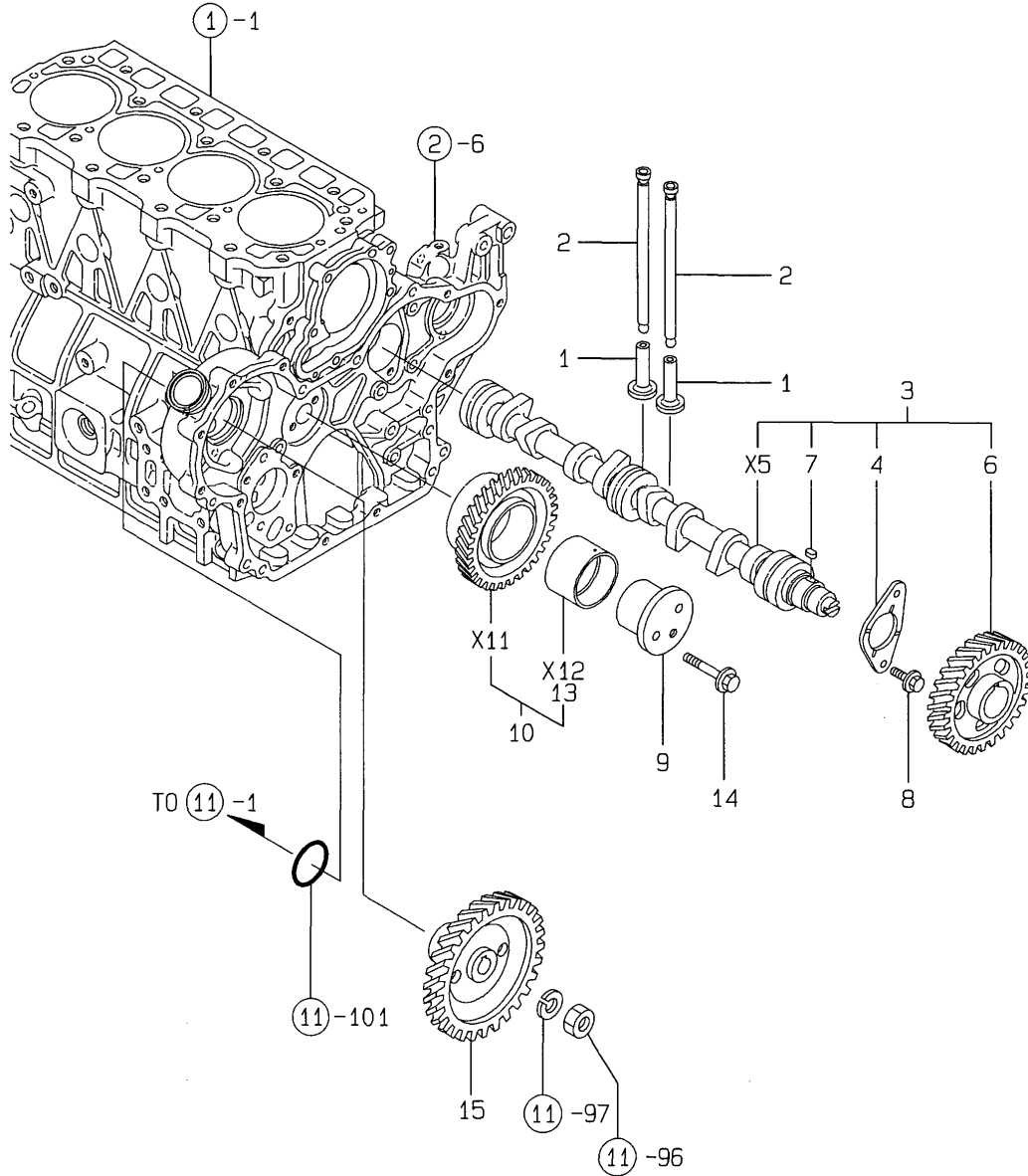

No.	Lev.	Parts No.	Description	Q'ty						I	R
				(A)	(B)	(C)	(D)	(E)	(F)		
1	1	129150-14200	TAPPET	8							
2	1	129900-14400	ROD, PUSH	8							
3	1	129900-14580	CAMSHAFT ASSY	1							
4	2	129150-02450	BEARING, THRUST	1							
6	2	129900-14100	GEAR, CAMSHAFT	1							
7	2	22512-070140	KEY, 7X 14	1							
8	1	26106-080162	BOLT, M8X 16 PLATED	2							
9	1	129900-25060	SHAFT, IDLE	1							
10	1	129900-25100	GEAR ASSY, IDLE	1							
13	2	129150-25920	BUSH, IDLE GEAR	1							1
14	1	26106-080552	BOLT, M8X 55 PLATED	2							
15	1	129900-25900	GEAR, PUMP	1							



Remarks
(1) REPAIR PART.

8, CRANKSHAFT & PISTON

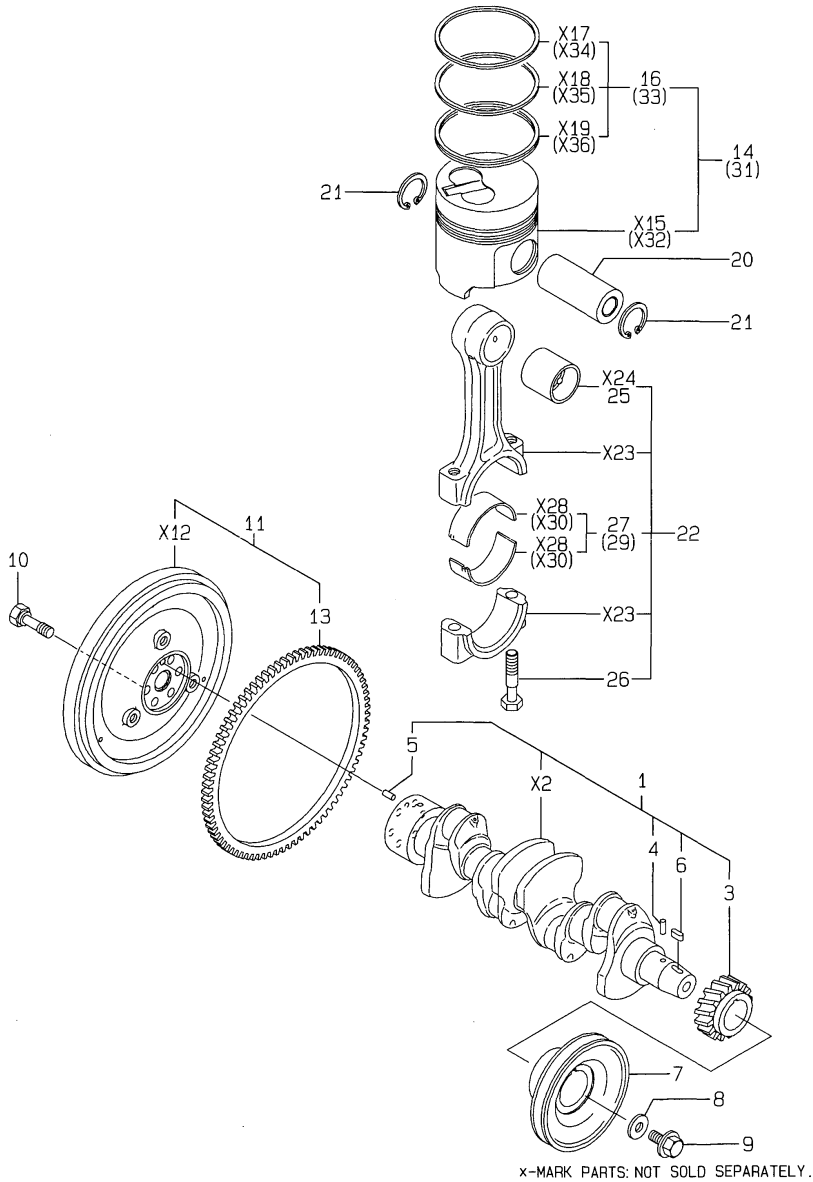

No.	Lev.	Parts No.	Description	Q'ty						I	R
				(A)	(B)	(C)	(D)	(E)	(F)		
1	1	129900-21000	CRANKSHAFT ASSY	1							
3	2	129900-21200	GEAR, CRANKSHAFT	1							
4	2	121850-21290	PIN	1							
5	2	121850-21920	PIN, M10X22	1							
6	2	22512-070140	KEY, 7X 14	1							
7	1	129900-21660	V-PULLEY, 130	1							
8	1	129900-21640	WASHER	1							
9	1	121850-21680	BOLT	1							
10	1	121850-21130	BOLT, FLYWHEEL	6							
11	1	129920-21580	FLYWHEEL	1							
13	2	127410-21480	GEAR, RING Z=129	1							
14	1	129900-22080	PISTON ASSY, DI	4							
16	2	129901-22050	RING SET, PISTON	4							
20	1	120130-22301	PIN, PISTON	4							
21	1	22252-000300	RING, 30	8							
22	1	129900-23000	ROD ASSY, CONNECTING	4							
25	2	129900-23910	BEARING, PISTON PIN	4							1
26	2	129900-23200	BOLT, CONNECTING ROD	8							
27	2	129900-23600	BEARING, CRANK PIN	4							
29	1	129900-23610	BEARING, 0.25 US	4							2
31	1	129900-22900	PISTON ASSY, 0.25 OS	4							3
33	2	129901-22950	RING SET, 0.25 OS	4							3

Remarks

- (1) REPAIR PART.
- (2) UNDER-SIZE(U.S=0.25)PART.
- (3) OVER-SIZE(O.S=0.25)PART.

9, LUB. OIL SYSTEM

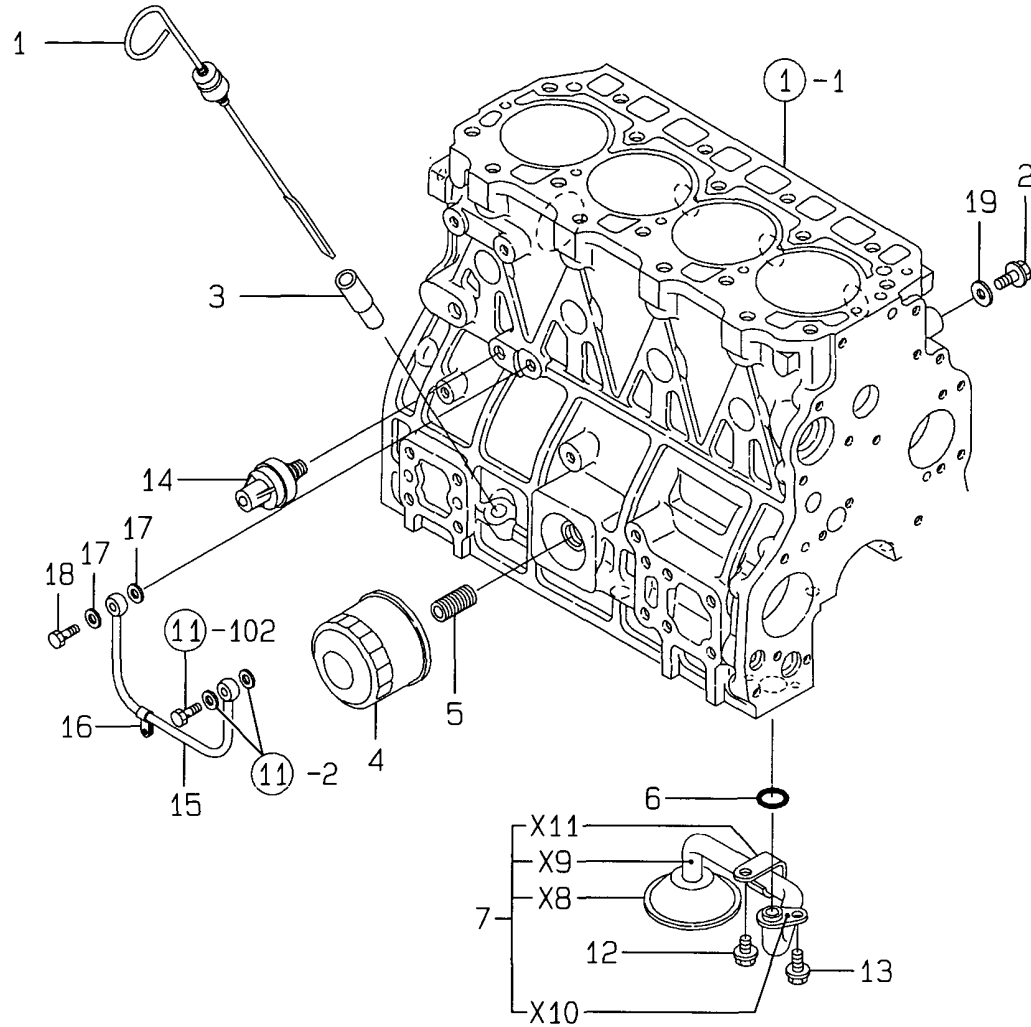

(A)=4TNE94-ACG
(B)=
(C)=

(D)=
(E)=
(F)=

No.	Lev.	Parts No.	Description	Q'ty						I	R
				(A)	(B)	(C)	(D)	(E)	(F)		
1	1	129900-34800	DIPSTICK, OIL	1							
2	1	26106-080122	BOLT, M8X 12 PLATED	1							
3	1	121520-34810	GUIDE, DIPSTICK	1							
4	1	129150-35151	FILTER, D80XL80	1							
5	1	119000-35140	BOLT, FILTER	1							
6	1	129900-32030	O-RING, P20	1							
7	1	129900-35000	PIPE ASSY, OIL INLET	1							
12	1	26106-080122	BOLT, M8X 12 PLATED	1							
13	1	26106-080162	BOLT, M8X 16 PLATED	1							
14	1	119265-39450	SWITCH	1							
15	1	129900-39350	PIPE, OIL	1							
16	1	23297-060081	CLAMP, A6X 8	1							
17	1	23414-080000	GASKET, 8X1.0	2							
18	1	23857-030000	BOLT, JOINT 3	1							
19	1	22190-080002	WASHER, SEAL 6	1							

10. COOLING WATER SYSTEM

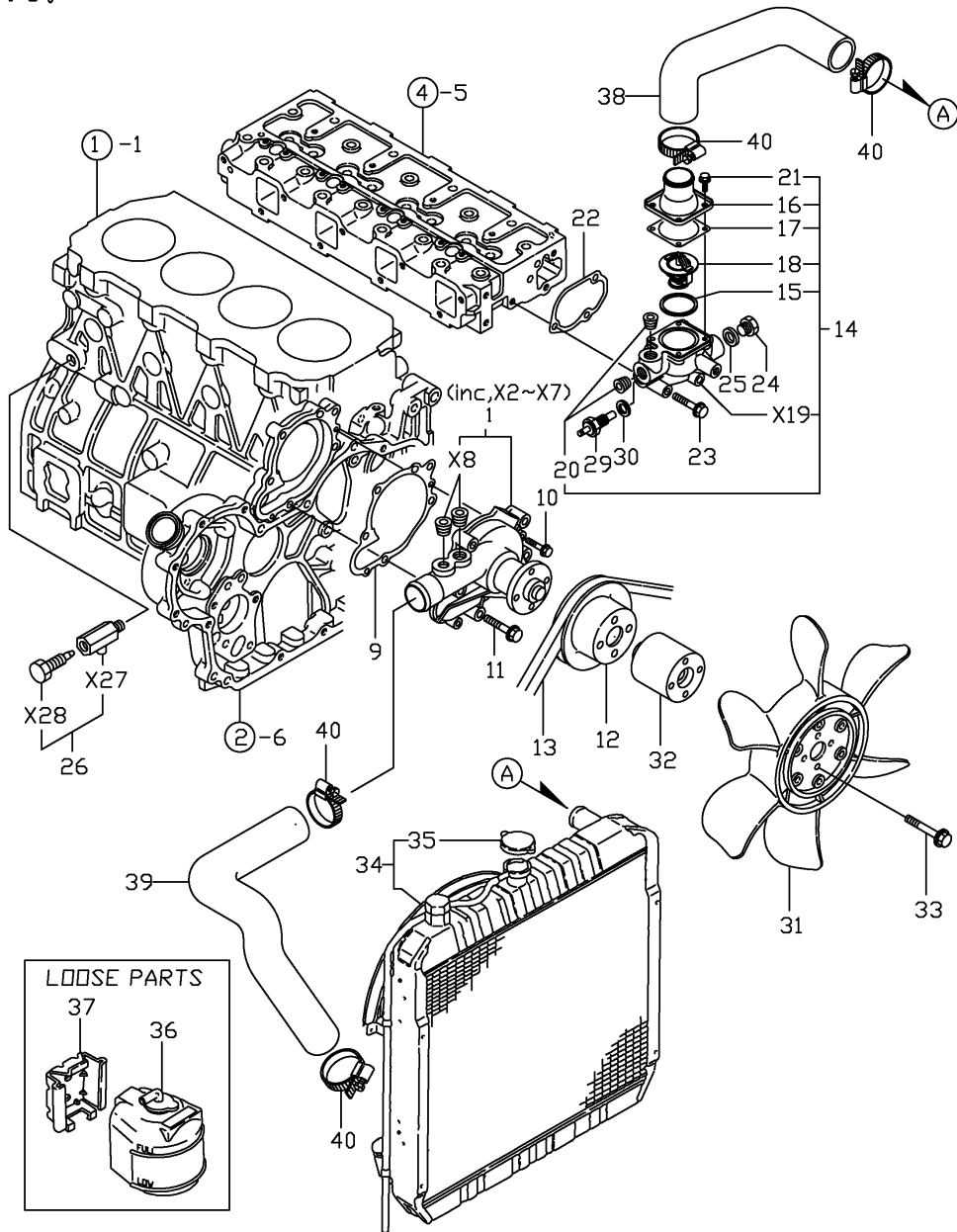

X-MARK PARTS: NOT SOLD SEPARATELY.

(A)=4TNE94-ACG

(B)=

(C)=

(D)=

(E)=

(F)=

No.	Lev.	Parts No.	Description	Q'ty						I	R
				(A)	(B)	(C)	(D)	(E)	(F)		
1	1	129900-42001	PUMP ASSY, WATER	1							
9	1	129900-42020	GASKET, WATER PUMP	1							
10	1	26106-060302	BOLT, M6X 30 PLATED	2							
11	1	26106-080552	BOLT, M8X 55 PLATED	5							
12	1	129900-42450	V-PULLEY	1							
13	1	25132-004200	V-BELT, A42	1							
14	1	129900-49860	CASE ASSY, THERMOSTAT	1							
15	2	121850-49550	GASKET, THERMOSTAT	1							
16	2	121850-49530	COVER, THERMOSTAT	1							
17	2	121850-49540	GASKET, THERMOSTAT	1							
18	2	121850-49810	THERMOSTAT, 71	1							
20	2	23871-030000	PLUG, R03	2							
21	2	26106-060142	BOLT, M6X 14 PLATED	4							
22	1	129900-49870	GASKET	1							
23	1	26106-080602	BOLT, M8X 60 PLATED	3							
24	1	121450-42450	PLUG, M16	1							
25	1	124465-44950	GASKET, 16	1							
26	1	119620-49290	COCK ASSY, 1/4	1							
29	1	129110-44900	SWITCH	1							
30	1	124465-44950	GASKET, 16	1							
31	1	129900-44700	FAN, COOLING D=410	1							
32	1	119117-44760	SPACER, FAN	1							
33	1	26106-080802	BOLT, M8X 80 PLATED	4							
34	1	171093-44500	RADIATOR	1							
35	2	119259-44570	CAP, RADIATOR	1							
36	1	120445-44530	TANK, SUB	1							
37	1	120445-44540	SUPPORT	1							
38	1	129915-49010	PIPE, WATER	1							
39	1	129911-49020	PIPE, WATER	1							
40	1	23000-054000	CLAMP, 54	4							

11.FUEL INJECTION PUMP

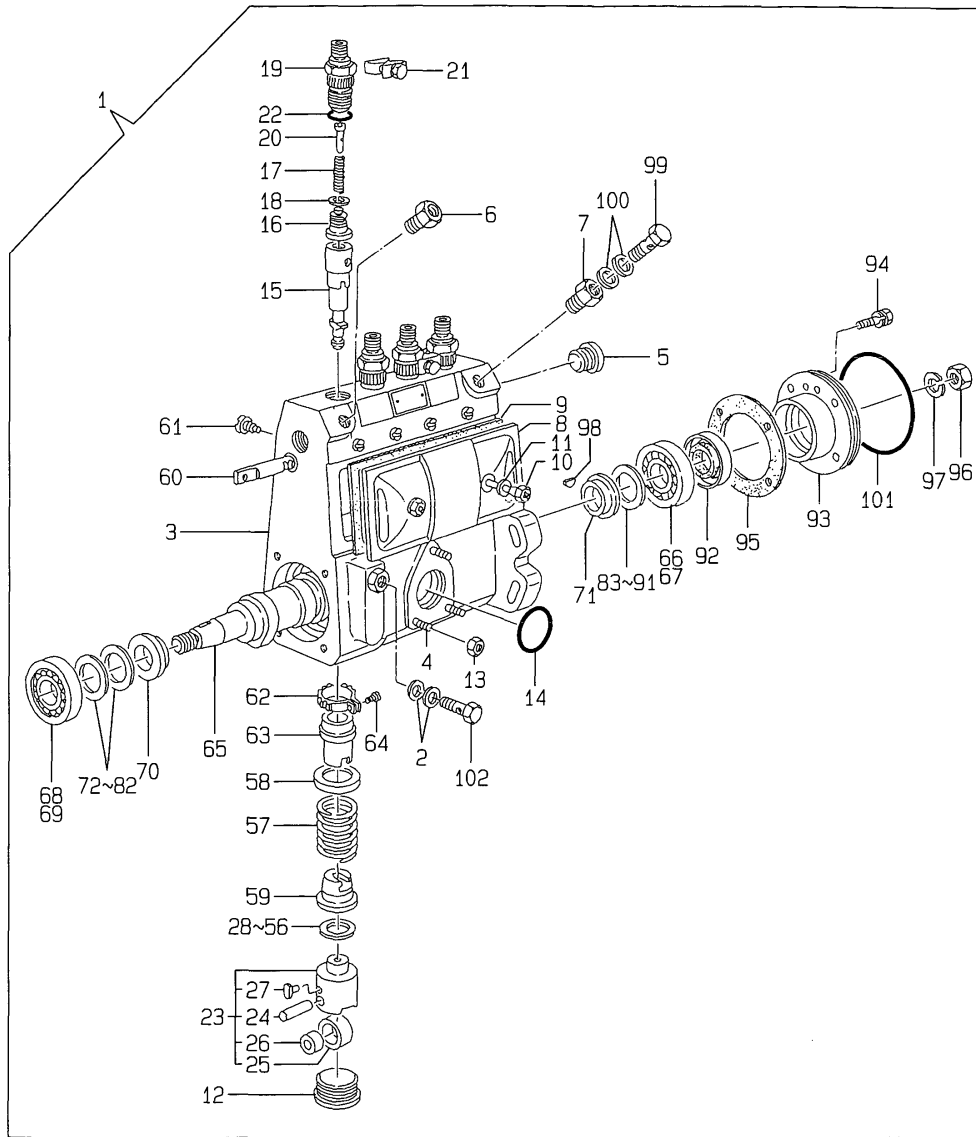

Remarks
 (1) GOVERNOR(FIG.NO.12) & FEED PUMP
 (FIG.NO.13) IS INCORPORATED IN
 THIS FUEL INJECTION PUMP
 (REF.NO.1).

(A)=4TNE94-ACG
 (B)=
 (C)=

(D)=
 (E)=
 (F)=

No.	Lev.	Parts No.	Description	Q'ty						I	R
				(A)	(B)	(C)	(D)	(E)	(F)		
1	1	129915-51020	PUMP ASSY, INJECTION	1							1
2	2	X0265101340	GASKET	2							
3	2	X1310641621	FLANGED HOUSING	1							
4	2	X0290406020	STUD	3							
5	2	X1340260000	PLUG	1							
6	2	X1310022000	CAP	1							
7	2	X1310022000	CAP	1							
8	2	X1310286220	COVER	1							
9	2	X1310111900	GASKET	1							
10	2	X1310171000	SCREW	2							
11	2	X0293406020	GASKET	2							
12	2	X1310341401	PLUG	4							
13	2	X1392060400	NUT	3							
14	2	X0296331010	O-RING	1							
15	2	X1311540820	PLUNGER ASSY	4							
16	2	X1311607920	DELIVERY VALVE	4							
17	2	X1311123500	SPRING	4							
18	2	X1311151600	GASKET	4							
19	2	X1311167600	HOLDER	4							
20	2	X1311172300	STOPPER	4							
21	2	X1311220520	PLATE	2							
22	2	X0296320030	O-RING, 21X17X2	4							
23	2	X1312000220	TAPPET	4							
24	3	X1312030200	PIN	4							
25	3	X1312041000	ROLLER	4							
26	3	X1312050500	BUSH	4							
27	3	X1312060200	GUIDE	4							
28	2	X0293110020	SHIM	1							
29	2	X0293110030	SHIM	1							
30	2	X0293110040	SHIM	1							
31	2	X0293110050	SHIM	1							
32	2	X0293110060	SHIM	1							
33	2	X0293110070	SHIM	1							
34	2	X0293110080	SHIM	1							
35	2	X0293110090	SHIM	1							
36	2	X0293110110	SHIM	1							
37	2	X0293110120	SHIM	1							
38	2	X0293110130	SHIM	1							
39	2	X0293110140	SHIM	1							
40	2	X0293110270	SHIM	1							
41	2	X0293110280	SHIM	1							
42	2	X0293110290	SHIM	1							
43	2	X0293110310	SHIM	1							
44	2	X0293110320	SHIM	1							
45	2	X0293110330	SHIM	1							
46	2	X0293110340	SHIM	1							
47	2	X0293110350	SHIM	1							
48	2	X0293110490	SHIM	1							
49	2	X0293110500	SHIM	1							
50	2	X0293110580	SHIM	1							
51	2	X0293110590	SHIM	1							

11.FUEL INJECTION PUMP

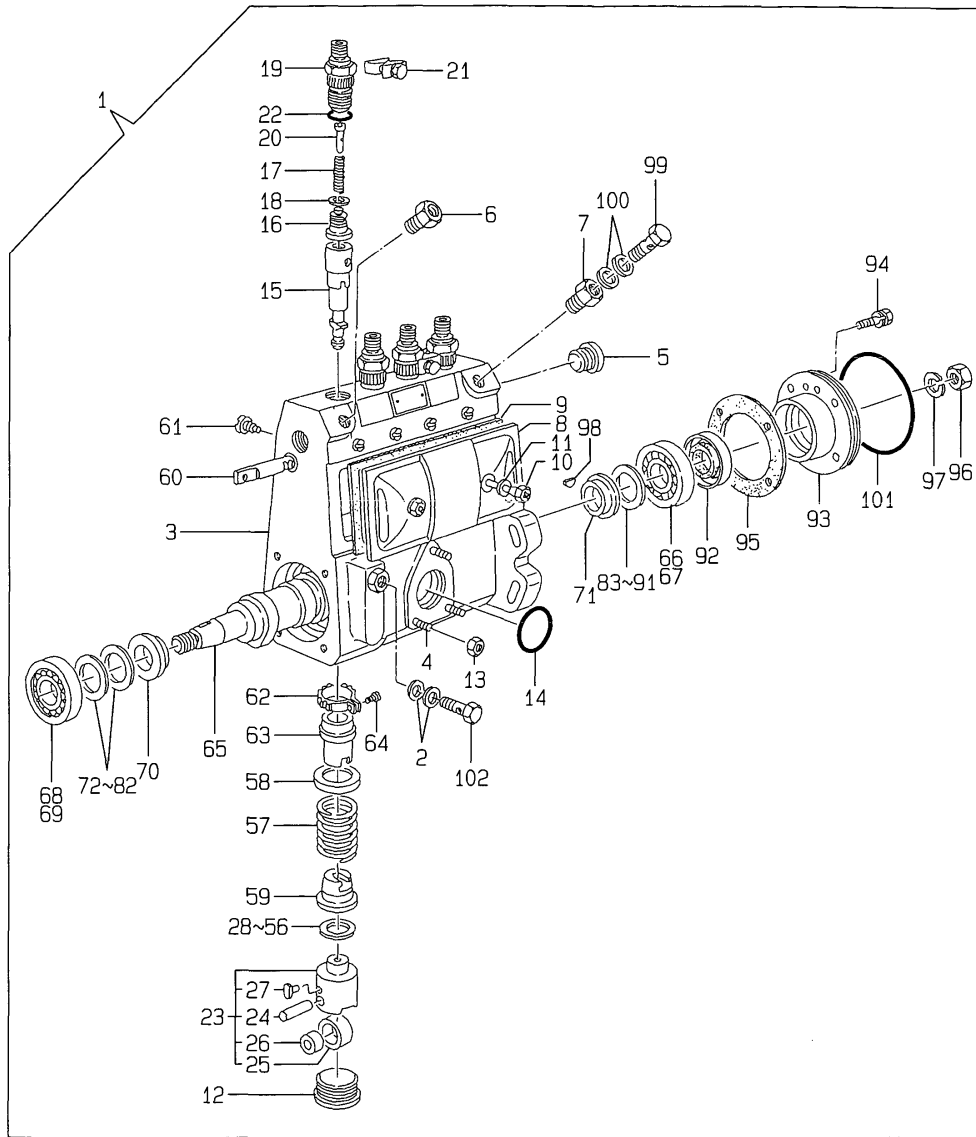

Remarks
 (1) GOVERNOR(FIG.NO.12) & FEED PUMP
 (FIG.NO.13) IS INCORPORATED IN
 THIS FUEL INJECTION PUMP
 (REF.NO.1).

(A)=4TNE94-ACG

(B)=

(C)=

(D)=

(E)=

(F)=

No.	Lev.	Parts No.	Description	Q'ty						I	R
				(A)	(B)	(C)	(D)	(E)	(F)		
52	2	X0293110600	SHIM	1							
53	2	X0293110610	SHIM	1							
54	2	X0293110620	SHIM	1							
55	2	X0293110630	SHIM	1							
56	2	X0293110710	SHIM	1							
57	2	X1312152500	SPRING	4							
58	2	X1312160100	SEAT, SPRING	4							
59	2	X1312170200	SEAT, SPRING	4							
60	2	X1312540600	RACK, CONTROL	1							
61	2	X1312260300	SCREW	1							
62	2	X1312400100	PINION	4							
63	2	X1312410100	SLEEVE, CONTROL	4							
64	2	X1312420100	SCREW	4							
65	2	X1313612700	CAMSHAFT	1							
66	2	X0166402030	BEARING	1							
67	2	X0282020020	BEARING	1							
68	2	X0166302030	BEARING	1							
69	2	X0282017020	BEARING	1							
70	2	X1313020300	RING	1							
71	2	X1313021000	RING	1							
72	2	X0293117010	SHIM	1							
73	2	X0293117020	SHIM	1							
74	2	X0293117030	SHIM	1							
75	2	X0293117040	SHIM	1							
76	2	X0293117050	SHIM	1							
77	2	X0293117060	SHIM	1							
78	2	X0293117070	SHIM	1							
79	2	X0293117090	SHIM	1							
80	2	X0293117210	SHIM	1							
81	2	X0293117220	SHIM	1							
82	2	X1394170000	SHIM	1							
83	2	X0293120220	SHIM	1							
84	2	X0293120230	SHIM	1							
85	2	X0293120240	SHIM	1							
86	2	X0293120250	SHIM	1							
87	2	X0293120260	SHIM	1							
88	2	X0293120270	SHIM	1							
89	2	X0293120290	SHIM	1							
90	2	X0293120300	SHIM	1							
91	2	X1394200400	SHIM	1							
92	2	X0296220190	SEAL, D30/20 T=6	1							
93	2	X1313301800	COVER	1							
94	2	X0200062040	BOLT	4							
95	2	X1313211900	GASKET	1							
96	2	X0131214140	NUT	1							
97	2	X0293214010	SPRING WASHER	1							
98	2	X0294704030	WOODRUFF KEY	1							
99	2	X0297314680	EYE BOLT	1							
100	2	X0265141840	GASKET	2							
101	2	X0296375020	O-RING	1							
102	2	X0297310120	EYE BOLT	1							

N:Old $\xrightarrow{\text{Yes}}$ New, Q:Old $\xrightarrow{\text{No}}$ New, R:Old $\xrightarrow{\text{Yes}}$ New, S:Old $\xrightarrow{\text{No}}$ New, W:Add, Z:Discontinued, F:Interchangeable by set, K:Q'ty Change

12. GOVERNOR

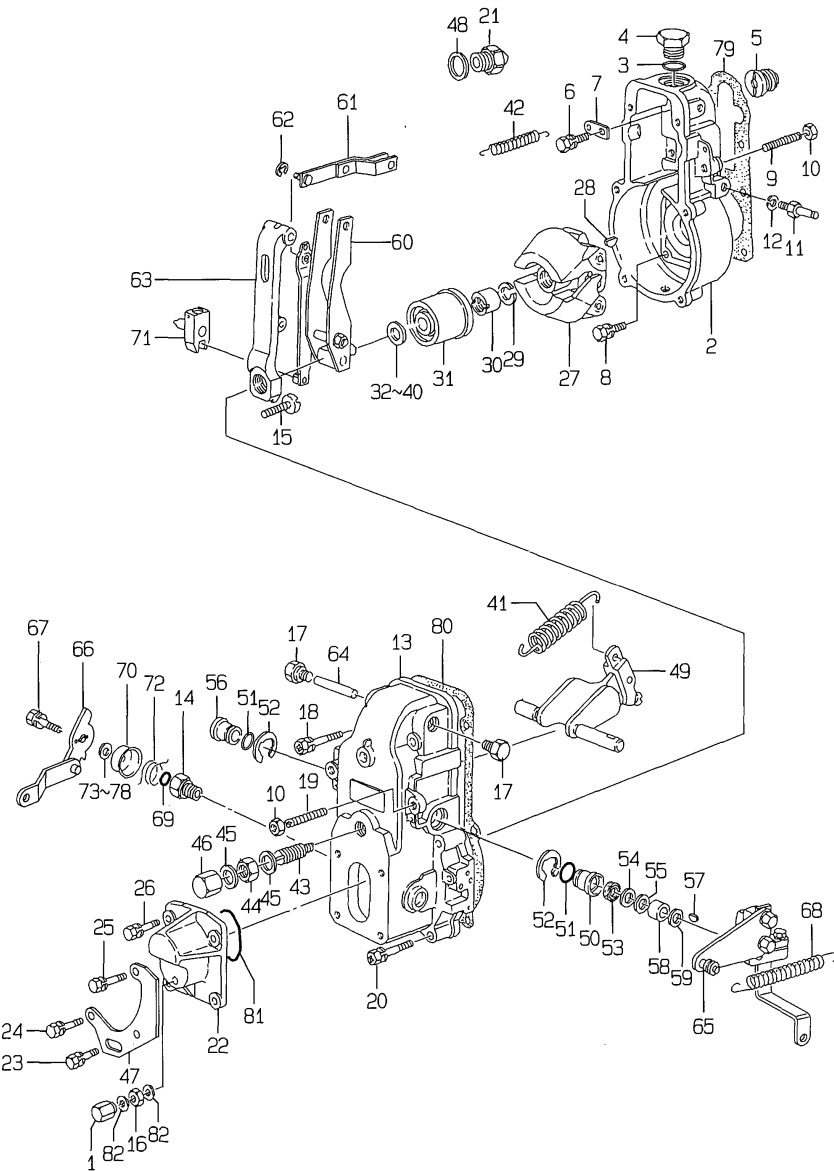

No.	Lev.	Parts No.	Description	Qty						I	R
				(A)	(B)	(C)	(D)	(E)	(F)		
1	2	X1540351600	CAP NUT	1							
2	2	X1540006400	FLANGED HOUSING	1							
3	2	X0296325070	O-RING	1							
4	2	X1540072900	PLUG	1							
5	2	X1540070200	ADAPTOR	1							
6	2	X0200181840	BOLT	1							
7	2	X1543501900	PLATE	1							
8	2	X0290106810	BOLT	6							
9	2	X1540101100	SCREW	1							
10	2	X1540110100	NUT	2							
11	2	X1540132320	BOLT	1							
12	2	X0141108440	SPRING WASHER	1							
13	2	X1545001020	COVER	1							
14	2	X1543210400	BUSH	1							
15	2	X1540313000	SCREW	1							
16	2	X1392060600	NUT	1							
17	2	X1540360300	PLUG	2							
18	2	X0201065040	BOLT	2							
19	2	X1540100100	SCREW	1							
20	2	X0201063840	BOLT	4							
21	2	X1530205220	LIMITER	1							
22	2	X1540635100	COVER	1							
23	2	X0290206260	BOLT	1							
24	2	X0290206260	BOLT	1							
25	2	X0200062040	BOLT	1							
26	2	X0200061640	BOLT	1							
27	2	X1541010020	FLYWAIGHT ASSY.	1							
28	2	X0258031610	WOODRUFF KEY	1							
29	2	X0293212020	SPRING WASHER	1							
30	2	X0292312030	NUT	1							
31	2	X1541230120	SLEEVE	1							
32	2	X0293110010	SHIM T0.2 D14/10.1	1							
33	2	X0293110180	SHIM T0.3 D14/10.1	1							
34	2	X0293110190	SHIM T0.4 D14/10.1	1							
35	2	X0293110210	SHIM T1.0 D14/10.1	1							
36	2	X1394100000	SHIM T0.5 D14/10.1	1							
37	2	X1394100100	SHIM T1.5 D14/10.1	1							
38	2	X1394103000	SHIM T2.0 D14/10.1	1							
39	2	X1394103100	SHIM T3.0 D14/10.1	1							
40	2	X1394103200	SHIM T4.0 D14/10.1	1							
41	2	X1541500400	SPRING	1							
42	2	X1541540701	SPRING	1							
43	2	X1541581720	SPRING CAPSULE	1							
44	2	X1540111700	NUT	1							
45	2	X0265121540	GASKET	2							
46	2	X1541591200	NUT, CAP	1							
47	2	X1543587200	BRACKET	1							
48	2	X0265182240	GASKET	1							
49	2	X1542006920	LEVER	1							
50	2	X1542043000	BUSH	1							
51	2	X0296318020	O-RING	2							

Remarks
 * THIS FIGURE(GOVERNOR ASSY)IS
 INCORPORATED IN THE FUEL INJECTION
 PUMP ASSY(FIG.11).

12. GOVERNOR

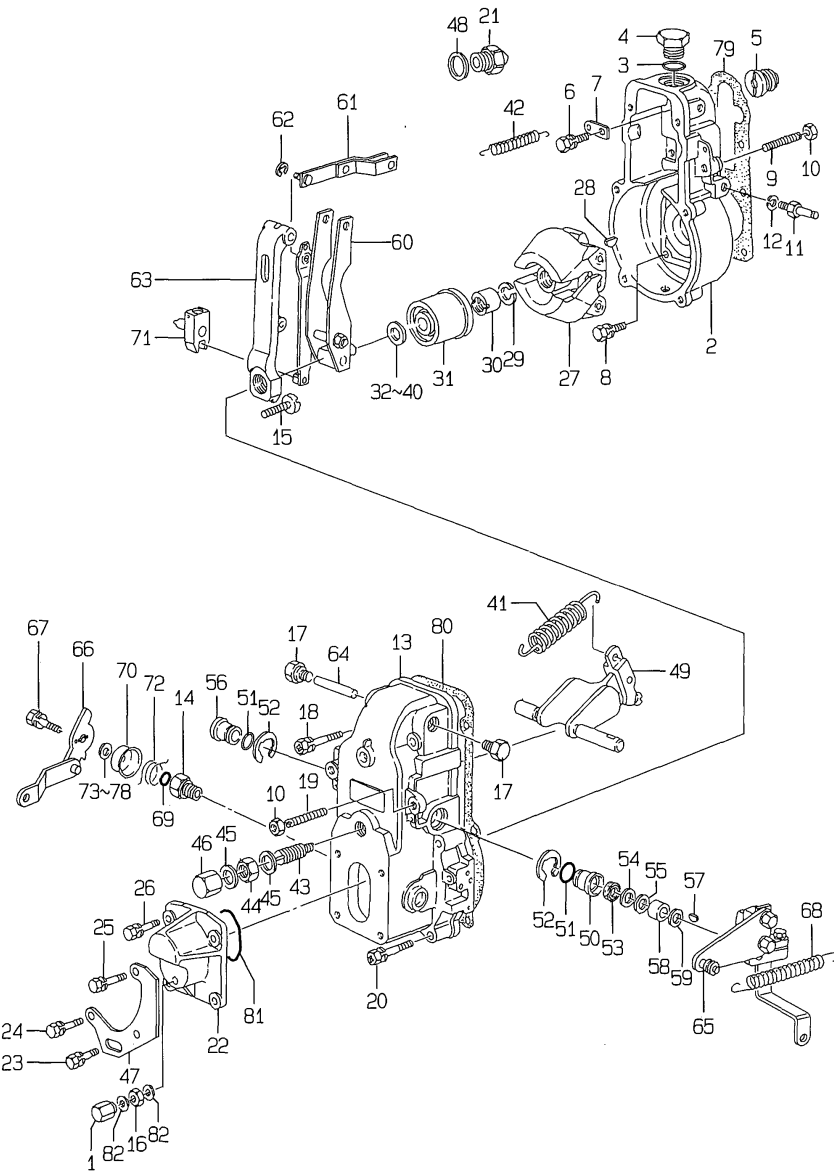

(A)=4TNE94-ACG

(B)=

(C)=

(D)=

(E)=

(F)=

No.	Lev.	Parts No.	Description	Qty						I	R
				(A)	(B)	(C)	(D)	(E)	(F)		
52	2	X0160101640	RING, SNAP	2							
53	2	X1396110000	SEAL, OIL	1							
54	2	X1394110000	SHIM	1							
55	2	X0293111070	SHIM	1							
56	2	X1542043100	BUSH	1							
57	2	X0258031310	WOODRUFF KEY	1							
58	2	X1542062800	COLLAR	1							
59	2	X1542060200	WASHER	1							
60	2	X1542163820	LEVER ASSY, GUIDE	1							
61	2	X1542303920	LINK	1							
62	2	X0160100540	RING, SNAP	1							
63	2	X1542364100	LEVER, TENSION	1							
64	2	X1542370100	PIN	1							
65	2	X1543956420	LEVER	1							
66	2	X1543829320	LEVER	1							
67	2	X0200061640	BOLT	1							
68	2	X1543142600	SPRING	1							
69	2	X0296310030	O-RING	1							
70	2	X1543220100	CAP	1							
71	2	X1543265020	LEVER ASSY	1							
72	2	X1543277400	SPRING	1							
73	2	X0293110520	SHIM	1							
74	2	X0293110530	SHIM	1							
75	2	X0293110540	SHIM	1							
76	2	X0293110550	SHIM	1							
77	2	X0293110560	SHIM	1							
78	2	X0293110570	SHIM	1							
79	2	X1543507700	GASKET	1							
80	2	X1543507800	GASKET	1							
81	2	X0296352020	O-RING	1							
82	2	X0265061040	GASKET	2							

Remarks

* THIS FIGURE(GOVERNOR ASSY)IS INCORPORATED IN THE FUEL INJECTION PUMP ASSY(FIG.11).

13. FEED PUMP

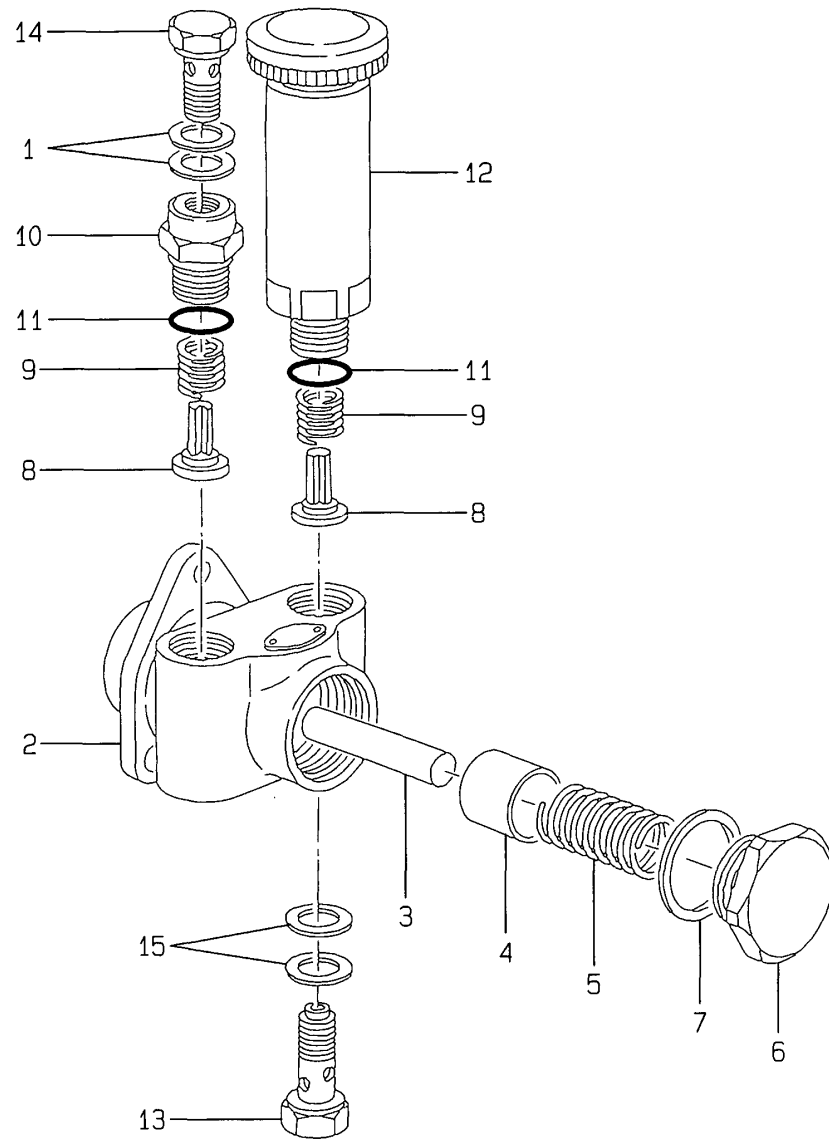

(A)=4TNE94-ACG
(B)=
(C)=

(D)=
(E)=
(F)=

No.	Lev.	Parts No.	Description	Q'ty						I	R
				(A)	(B)	(C)	(D)	(E)	(F)		
1	2	X0265141840	GASKET	2							
2	2	X1520620020	HOUSING	1							
3	2	X1520300200	ROD, PUSH	1							
4	2	X1521002301	PISTON	1							
5	2	X1521020400	SPRING, PISTON	1							
6	2	X1521051500	PLUG	1							
7	2	X1395260000	GASKET	1							
8	2	X1521150500	VALVE	2							
9	2	X1521160200	SPRING	2							
10	2	X1521180900	ADAPTER	1							
11	2	X0296316060	O-RING	2							
12	2	X1522006720	PRIMING PUMP	1							
13	2	X1523005920	BOLT	1							
14	2	X0297314680	EYE BOLT	1							
15	2	X0265141840	GASKET	2							

Remarks
* THIS FIGURE(FEED PUMP ASSY)IS
INCORPORATED IN THE FUEL INJECTION
PUMP ASSY(FIG.11).

14. FUEL INJECTION VALVE

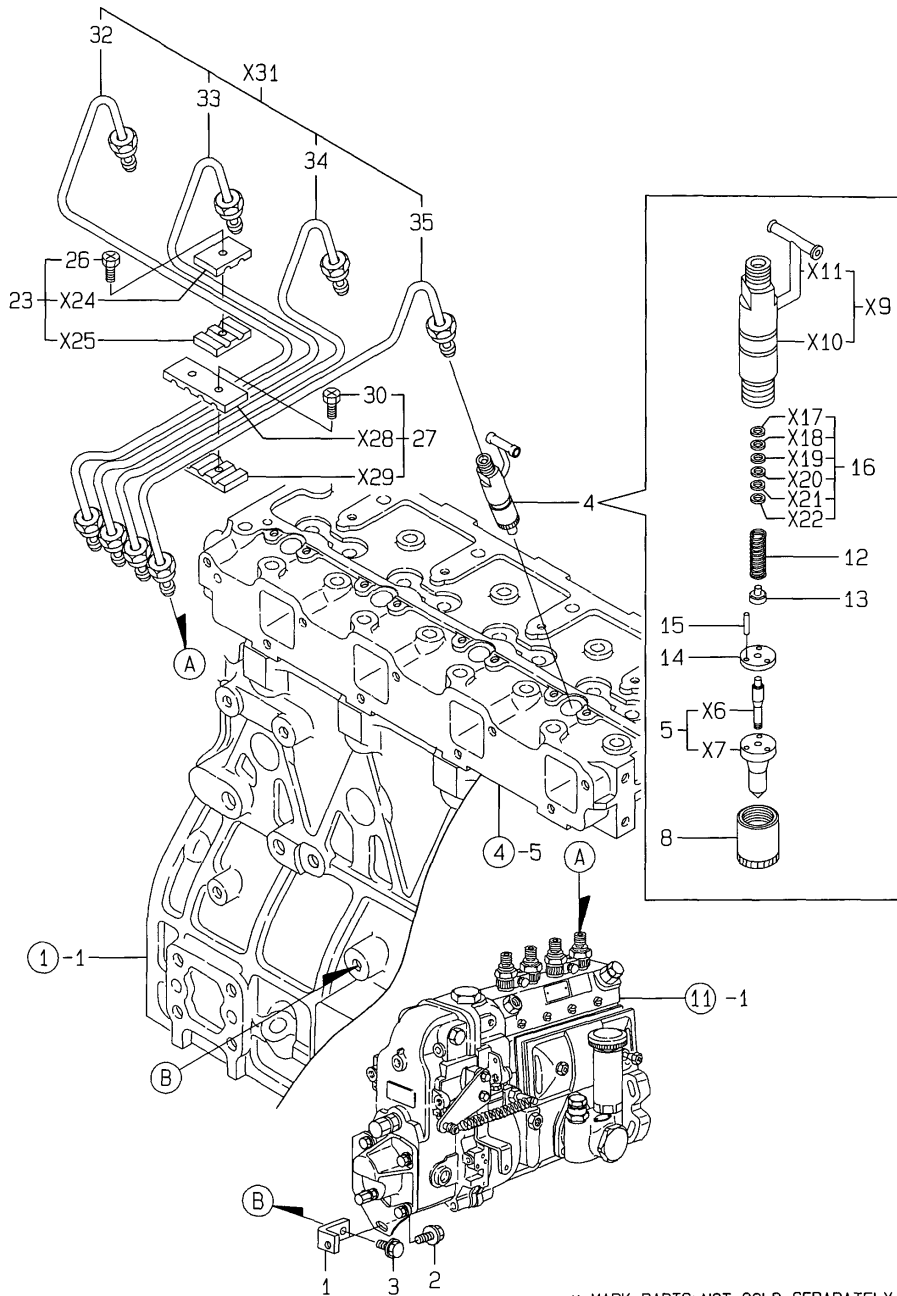

x-MARK PARTS: NOT SOLD SEPARATELY.

(A)=4TNE94-ACG

(B)=

(C)=

(D)=

(E)=

(F)=

No.	Lev.	Parts No.	Description	Q'ty						I	R
				(A)	(B)	(C)	(D)	(E)	(F)		
1	1	129900-01950	RETAINER	1							
2	1	26106-100142	BOLT, M10X 14 PLATED	1							
3	1	26106-080202	BOLT, M8X 20 PLATED	1							
4	1	729982-53100	VALVE ASSY,INJECTION	4							
5	2	129982-53000	VALVE ASSY,INJECTION	4							
8	2	114250-53080	NUT, NOZZLE D16.95	4							
12	2	114250-53120	SPRING, NOZZLE	4							
13	2	114250-53130	SEAT, SPRING	4							
14	2	114250-53140	PLATE	4							
15	2	114250-53210	PIN	8							
16	2	114250-53400	SHIM SET	4							
23	1	119305-59120	RETAINER, PIPE	2							
26	2	129150-59131	BOLT, M4X14	2							
27	1	129550-59120	RETAINER, PIPE	1							
30	2	129150-59131	BOLT, M4X14	2							
32	2	129902-59810	PIPE ASSY, INJECTION	1							
33	2	129902-59820	PIPE ASSY, INJECTION	1							
34	2	129902-59830	PIPE ASSY, INJECTION	1							
35	2	129902-59840	PIPE ASSY, INJECTION	1							

N:Old $\begin{matrix} \leftarrow \text{Yes} \\ \text{No} \end{matrix}$ New, Q:Old $\begin{matrix} \leftarrow \text{No} \\ \text{Yes} \end{matrix}$ New, R:Old $\begin{matrix} \leftarrow \text{Yes} \\ \text{Yes} \end{matrix}$ New, S:Old $\begin{matrix} \leftarrow \text{No} \\ \text{No} \end{matrix}$ New, W:Add, Z:Discontinued, F:Interchangeable by set, K:Q'ty Change

Copyright (C) YANMAR CO., LTD. All Rights Reserved.

15. FUEL LINE

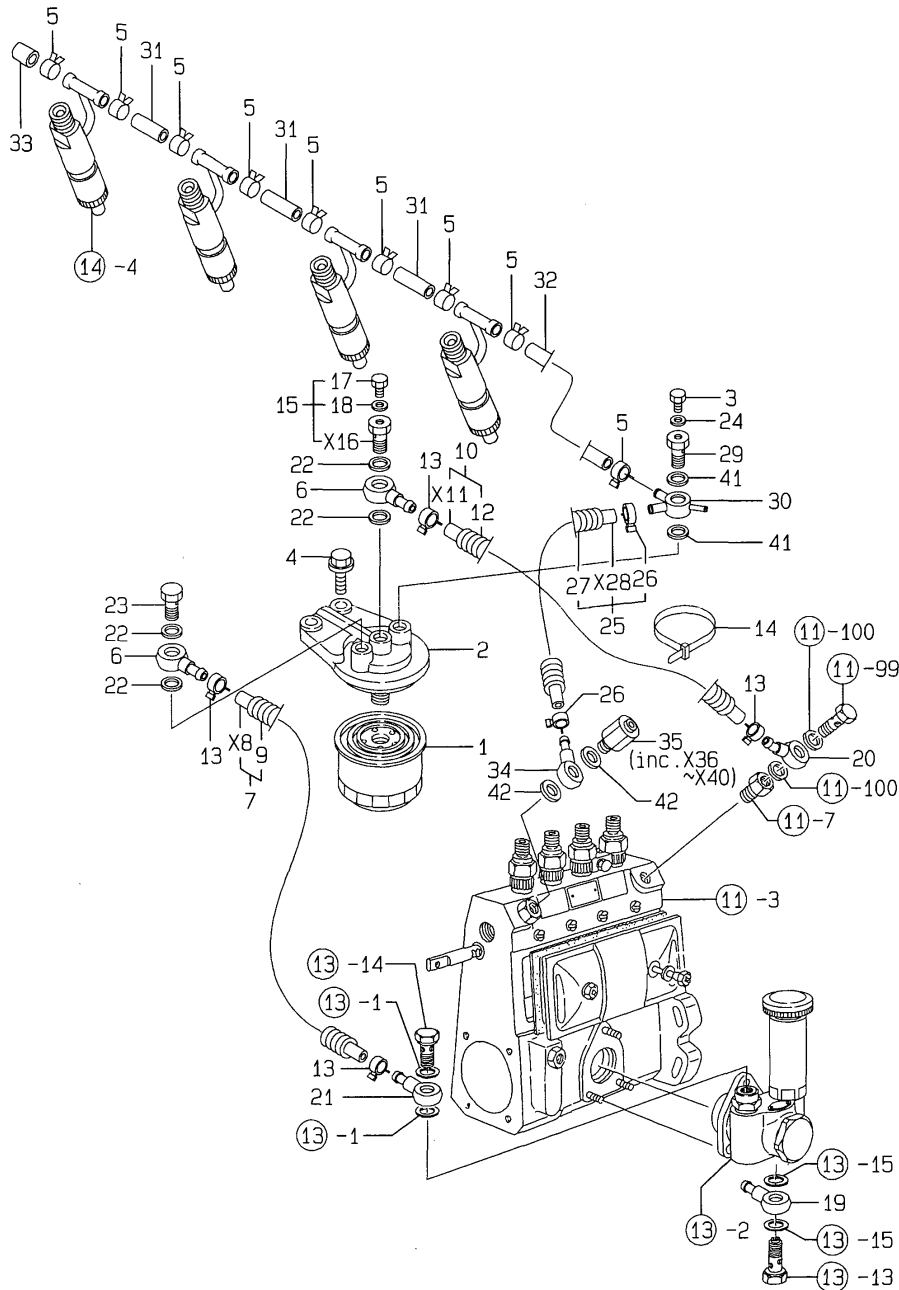

x-MARK PARTS: NOT SOLD SEPARATELY.

(A)=4TNE94-ACG

(B)=

(C)=

(D)=

(E)=

(F)=

No.	Lev.	Parts No.	Description	Q'ty						I	R
				(A)	(B)	(C)	(D)	(E)	(F)		
1	1	119000-55600	FILTER, FUEL	1							
2	1	129470-55610	BODY, STRAINER	1							
3	1	26106-080102	BOLT, M8X 10 PLATED	1							
4	1	26106-100252	BOLT, M10X 25 PLATED	2							
5	1	124066-59100	CLIP, HOSE 8	9							
6	1	101304-59020	JOINT, PIPE 12	2							
7	1	129957-59040	PIPE, FUEL	1							
9	2	119560-59110	TUBE, CORRUGATED	1							
10	1	129957-59040	PIPE, FUEL	1							
12	2	119560-59110	TUBE, CORRUGATED	1							
13	1	124766-59050	CLIP, HOSE 12	4							
14	1	121855-59111	CLAMP, PIPE 610	2							
15	1	103854-59191	BOLT ASSY, JOINT M12	1							
17	2	124060-59380	PLUG, 6	1							
18	2	22190-060002	WASHER, SEAL 6	1							
19	1	121855-59880	JOINT, PIPE	1							
20	1	121855-59880	JOINT, PIPE	1							
21	1	119006-59910	JOINT, PIPE	1							
22	1	22190-120002	WASHER, SEAL 12	4							
23	1	23857-060000	BOLT, JOINT 6	1							
24	1	23414-080000	GASKET, 8X1.0	1							
25	1	129950-59311	PIPE, FUEL	1							
26	2	124766-59050	CLIP, HOSE 12	2							
27	2	129961-59110	TUBE, CORRUGATED	1							
29	1	129495-59300	BOLT, PIPE JOINT	1							
30	1	129980-59530	JOINT	1							
31	1	121250-59550	PIPE, FUEL D8X120	3							
32	1	129915-59120	PIPE, FUEL RETURN	1							
33	1	129150-59580	CAP	1							
34	1	121855-59880	JOINT, PIPE	1							
35	1	128300-59910	VALVE ASSY, OVERFLOW	1							
41	1	22190-140002	WASHER, SEAL 14	2							
42	1	22190-140002	WASHER, SEAL 14	2							

N:Old $\begin{matrix} \leftarrow \text{Yes} \\ \text{No} \end{matrix}$ New, Q:Old $\begin{matrix} \leftarrow \text{No} \\ \text{Yes} \end{matrix}$ New, R:Old $\begin{matrix} \leftarrow \text{Yes} \\ \text{Yes} \end{matrix}$ New, S:Old $\begin{matrix} \leftarrow \text{No} \\ \text{No} \end{matrix}$ New, W:Add, Z:Discontinued, F:Interchangeable by set, K:Q'ty Change

Copyright (C) YANMAR CO., LTD. All Rights Reserved.

16, ENGINE STOP DEVICE

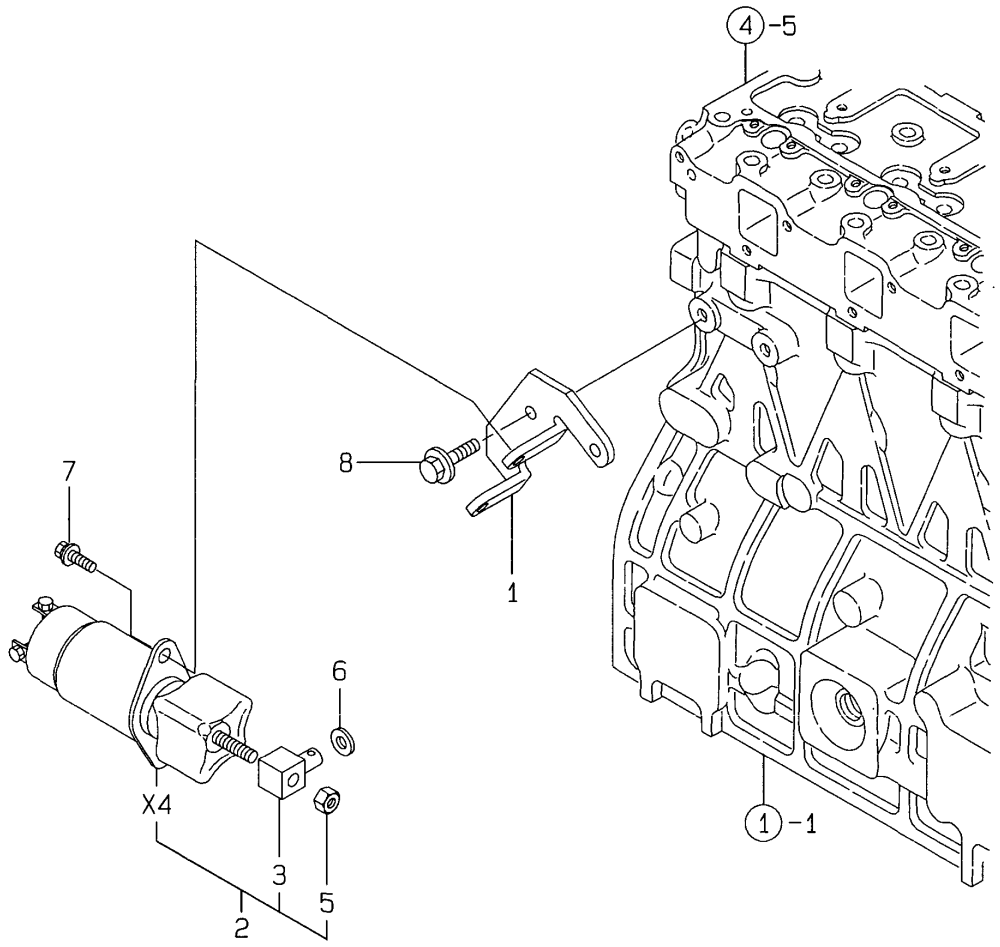

x-MARK PARTS: NOT SOLD SEPARATELY.

(A)=4TNE94-ACG
(B)=
(C)=

(D)=
(E)=
(F)=

No.	Lev.	Parts No.	Description	Q'ty						I	R
				(A)	(B)	(C)	(D)	(E)	(F)		
1	1	129915-66810	BRACKET, SOLENOID	1							
2	1	129955-77810	SOLENOID ASSY	1							
3	2	119620-66820	JOINT	1							
5	2	26716-060002	NUT, M6	1							
6	1	22117-060000	WASHER, 6	1							
7	1	26106-060102	BOLT, M6X 10 PLATED	2							
8	1	26106-080162	BOLT, M8X 16 PLATED	2							

17. STARTING MOTOR

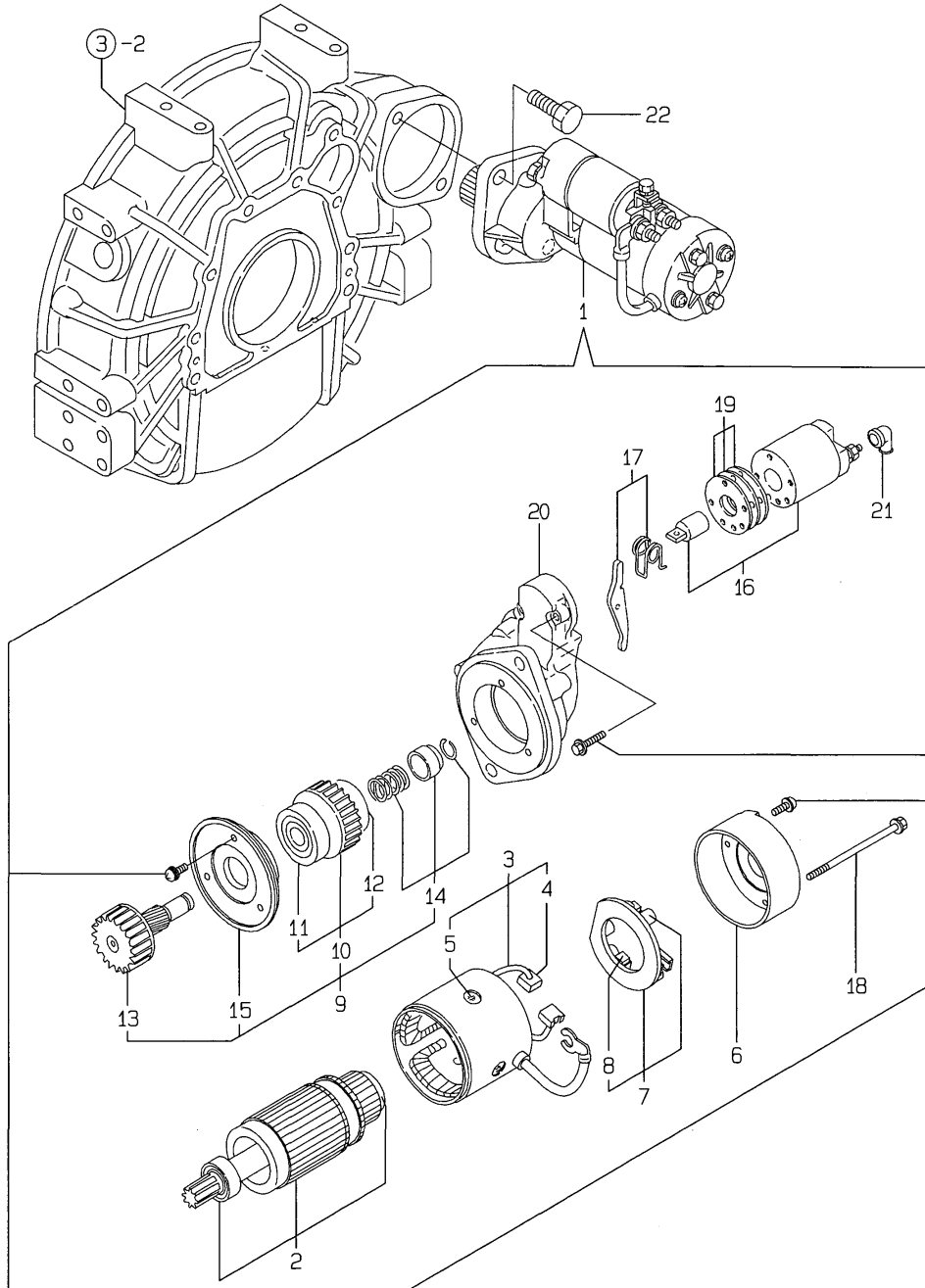

(A)=4TNE94-ACG

(B)=

(C)=

(D)=

(E)=

(F)=

No.	Lev.	Parts No.	Description	Qty						I	R
				(A)	(B)	(C)	(D)	(E)	(F)		
1	1	129900-77010	STARTER(2.3KW	1							
2	2	129900-77400	ARMATURE ASSY	1							
3	2	129900-77440	COIL ASSY, FIELD	1							
4	3	129900-77450	BRUSH (+)	2							
5	3	171008-77450	SCREW	4							
6	2	129900-77460	COVER, REAR	1							
7	2	129900-77480	HOLDER ASSY, BRASH	1							
8	3	129900-77500	BRASH (-)	2							
9	2	129900-77510	PINION ASSY	1							
10	3	129900-77520	CLUTCH ASSY	1							
11	4	171008-77730	BALL BEARING (3)	1							
12	4	171008-77740	BALL BEARING (4)	1							
13	3	129900-77540	SHAFT, PINION	1							
14	3	129900-77550	STOPPER SET	1							
15	3	129900-77610	RETAINER, BEARING	1							
16	2	129900-77590	SWITCH ASSY,MAGNETIC	1							
17	2	129900-77620	SHIFT LEVER SET	1							
18	2	129900-77640	BOLT, THROUGH	2							
19	2	129900-77650	COVER ASSY, DUST	1							
20	2	129900-77710	HOUSING, GEARS	1							
21	2	171008-77750	COVER, M TERMINAL	1							
22	1	26116-120302	BOLT, M12X 30 PLATED	2							

18. GENERATOR

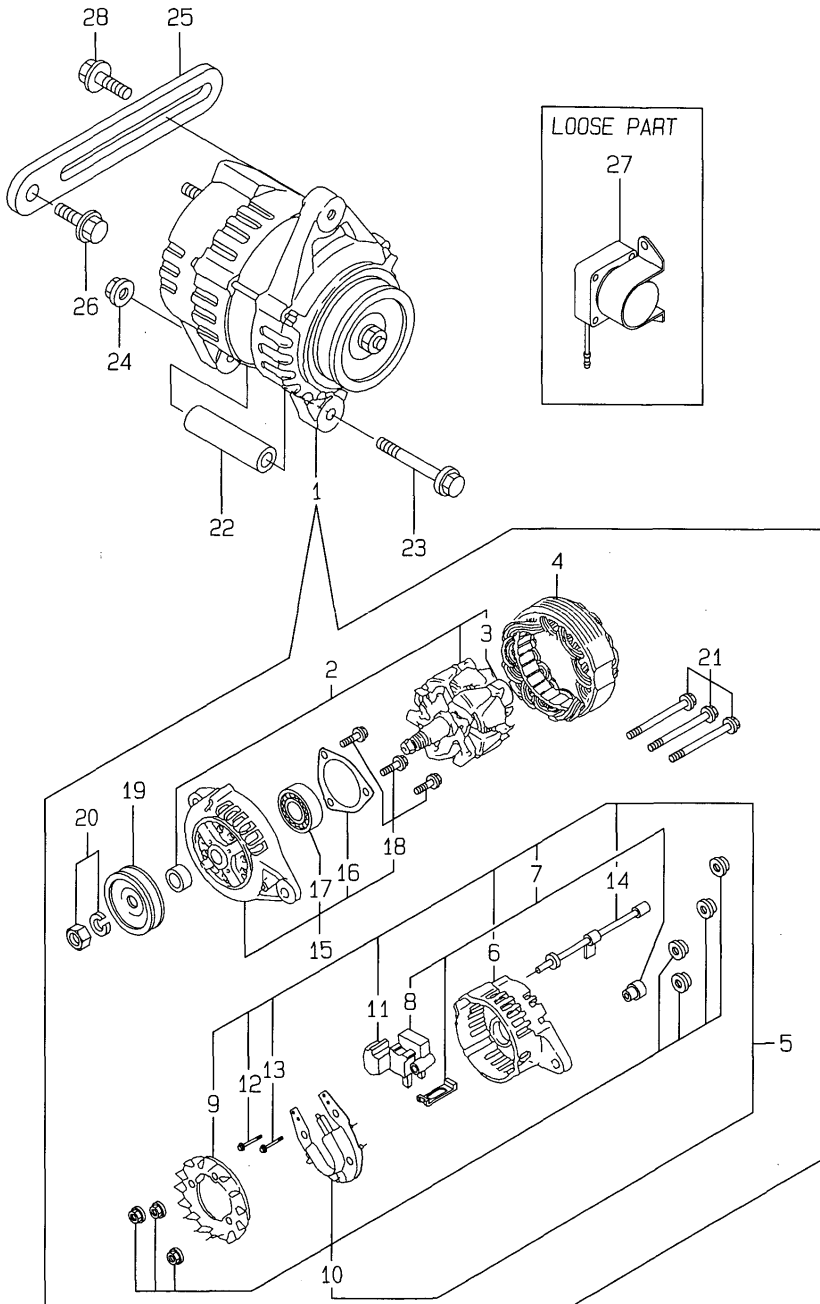

(A)=4TNE94-ACG

(B)=

(C)=

(D)=

(E)=

(F)=

No.	Lev.	Parts No.	Description	Q'ty						I	R
				(A)	(B)	(C)	(D)	(E)	(F)		
1	1	119836-77200	GENERATOR	1							
2	2	119836-77700	ROTOR ASSY	1							
3	3	119836-77850	BALL BEARING	1							
4	2	119836-77710	STATOR ASSY	1							
5	2	119836-77721	COVER ASSY, REAR	1							
6	3	119836-77730	COVER, REAR	1							
7	3	119836-77741	BRUSH ASSY,REGULATOR	1							
8	4	119836-77750	BRUSH ASSY	1							
9	3	119836-77760	GUIDE, FAN SIDE	1							
10	3	119836-77770	DIODE ASSY	1							
11	3	119836-77780	CONDENSER	1							
12	3	119836-77871	BOLT (1)	1							
13	3	119836-77880	BOLT (2)	1							
14	3	119836-77890	WIRE ASSY, LEAD	1							
15	2	119836-77790	COVER ASSY, FRONT	1							
16	3	119836-77800	RETAINER, BEARING	1							
17	3	119836-77840	BALL BEARING	1							
18	3	119836-77860	SCREW KID	1							
19	2	119836-77810	PULLEY	1							
20	2	119836-77820	NUT ASSY, PULLEY	1							
21	2	119836-77830	BOLT, THROUGH	1							
22	1	129150-77340	SPACER	1							
23	1	129136-77251	BOLT, M8X110	1							
24	1	26366-080002	NUT, M8	1							
25	1	129900-77330	ADJUSTER	1							
26	1	26014-080252	BOLT, M8X 25	1							
27	1	129100-77910	RELAY, MAGNETIC	2							
28	1	119810-77340	BOLT, ADJUSTER	1							

19. GASKET SET

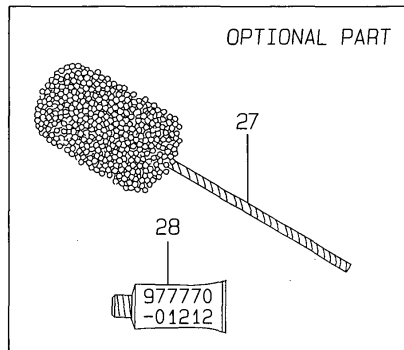
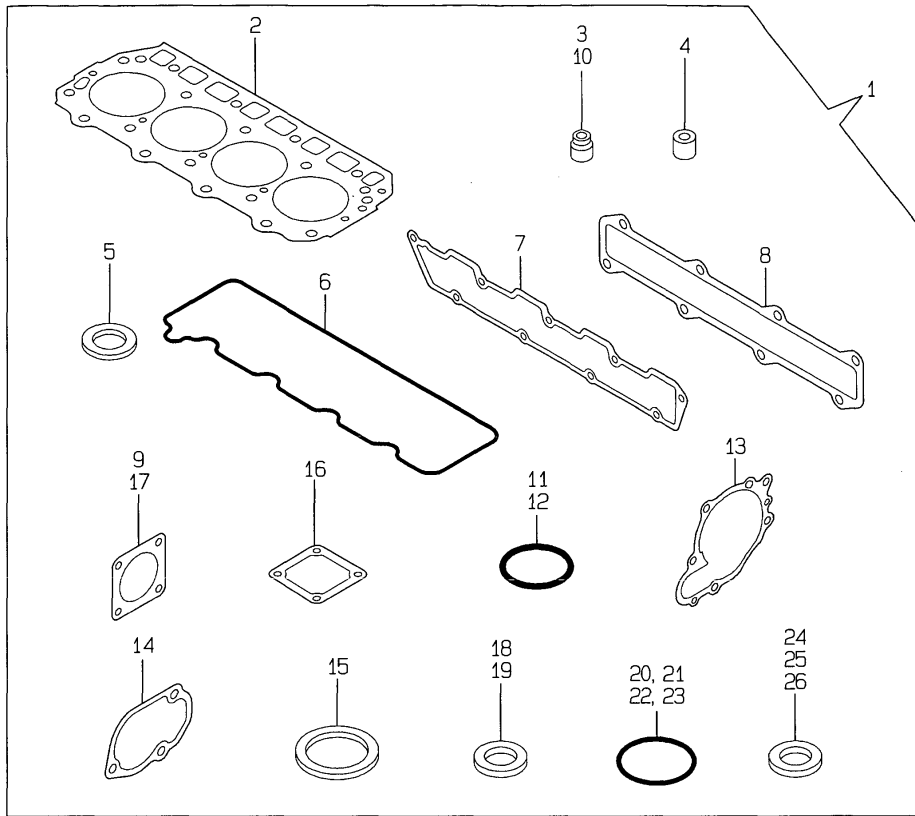

(A)=4TNE94-ACG

(B)=

(C)=

(D)=

(E)=

(F)=

No.	Lev.	Parts No.	Description	Q'ty						I	R
				(A)	(B)	(C)	(D)	(E)	(F)		
1	1	729900-92620	GASKET SET	1							1
2	2	129900-01331	GASKET, HEAD	1							
3	2	124460-11340	SEAL, VALVE STEM	4							
4	2	119625-11870	PROTECTOR, NOZZLE	4							
5	2	119625-11880	SEAT, NOZZLE	4							
6	2	129900-11310	GASKET, BONNET	1							
7	2	129900-12050	GASKET, MANIFOLD	1							
8	2	129900-13150	GASKET	1							
9	2	129400-13201	GASKET, SILENCER	1							
10	2	121400-11340	SEAL, VALVE STEM	4							
11	2	129900-32030	O-RING, P20	2							
12	2	129900-32040	O-RING, P14	1							
13	2	129900-42020	GASKET, WATER PUMP	1							
14	2	129900-49870	GASKET	1							
15	2	121850-49550	GASKET, THERMOSTAT	1							
16	2	121850-77021	GASKET	1							
17	2	121850-49540	GASKET, THERMOSTAT	1							
18	2	23414-080000	GASKET, 8X1.0	3							
19	2	124465-44950	GASKET, 16	2							
20	2	24311-000070	O-RING, 1AP7.0	1							
21	2	24311-000120	O-RING, 1AP12.0	3							
22	2	24341-000240	O-RING, 1AS24.0	1							
23	2	24311-000320	O-RING, 1AP32.0	2							
24	2	22190-080002	WASHER, SEAL 6	1							
25	2	22190-120002	WASHER, SEAL 12	4							
26	2	22190-140002	WASHER, SEAL 14	4							
27	1	129400-92440	HONE	1							1
28	1	977770-01212	GASKET, LIQUID	1							1

Remarks

(1) OPTIONAL PART.



Parts No. Index

Parts No.	Fig. No.	Ref. No.
101304-59020	15	6
103854-59191	15	15
114250-53080	14	8
114250-53120	14	12
114250-53130	14	13
114250-53140	14	14
114250-53210	14	15
114250-53400	14	16
119000-01840	3	3
119000-35140	9	5
119000-55600	15	1
119006-59910	15	21
119117-44760	10	32
119131-18320	6	5
119140-12040	5	7
119259-44570	10	35
119265-39450	9	14
119305-59120	14	23
119560-59110	15	9
	12	
119620-49290	10	26
119620-66820	16	3
119625-11870	4	19
	19	4
119625-11880	4	20
	19	5
119625-11900	4	21
119640-01640	3	8
119810-77340	18	28
119836-77200	18	1
119836-77700	18	2
119836-77710	18	4
119836-77721	18	5
119836-77730	18	6
119836-77741	18	7
119836-77750	18	8
119836-77760	18	9
119836-77770	18	10
119836-77780	18	11
119836-77790	18	15
119836-77800	18	16
119836-77810	18	19
119836-77820	18	20
119836-77830	18	21
119836-77840	18	17
119836-77850	18	3
119836-77860	18	18
119836-77871	18	12
119836-77880	18	13
119836-77890	18	14

Parts No.	Fig. No.	Ref. No.
120130-22301	8	20
120445-44530	10	36
120445-44540	10	37
121023-01550	2	24
121250-59550	15	31
121400-11340	4	16
	19	10
121450-42450	10	24
121520-34810	9	3
121850-21130	8	10
121850-21290	8	4
121850-21680	8	9
121850-21920	8	5
121850-49530	10	16
121850-49540	10	17
	19	17
121850-49550	10	15
	19	15
121850-49810	10	18
121850-77021	5	4
	19	16
121855-59111	15	14
121855-59880	15	19
	20	
	34	
124060-59380	15	17
124066-59100	15	5
124160-01751	2	22
	4	3
124160-11360	4	44
124411-01780	3	6
124460-11340	4	17
	19	3
124465-44950	10	25
	30	
	19	19
124766-59050	15	13
	26	
127410-21480	8	13
128300-59910	15	35
129100-01580	3	1
129100-77910	18	27
129110-44900	10	29
129136-77251	18	23
129150-02450	7	4
129150-11230	4	33
	37	
129150-11370	4	18
129150-11750	4	35
	39	

Parts No.	Fig. No.	Ref. No.
129150-11810	4	8
129150-14200	7	1
129150-25920	7	13
129150-35151	9	4
129150-59131	14	26
	30	
129150-59580	15	33
129150-77340	18	22
129400-13201	6	6
	19	9
129400-92440	19	27
129470-55610	15	2
129495-59300	15	29
129550-59120	14	27
129795-11180	4	15
129900-01200	1	21
129900-01331	1	22
	19	2
129900-01740	2	4
129900-01780	2	3
129900-01820	2	6
129900-01950	14	1
129900-02020	1	6
129900-02340	1	23
129900-02410	1	9
129900-02800	1	15
129900-02930	1	18
129900-02940	1	26
129900-07900	4	4
129900-11100	4	12
129900-11110	4	13
129900-11120	4	14
129900-11200	4	25
129900-11240	4	26
129900-11280	4	29
129900-11310	4	46
	19	6
129900-11370	4	45
129900-11510	4	30
129900-11520	4	31
129900-11530	4	42
129900-11600	4	48
129900-11650	4	32
129900-11660	4	36
129900-12050	5	1
	19	7
129900-12100	5	2
129900-13120	6	1
129900-13150	6	3
	19	8

Parts No.	Fig. No.	Ref. No.
129900-14100	7	6
129900-14400	7	2
129900-14580	7	3
129900-21000	8	1
129900-21200	8	3
129900-21640	8	8
129900-21660	8	7
129900-22080	8	14
129900-22900	8	31
129900-23000	8	22
129900-23200	8	26
129900-23600	8	27
129900-23610	8	29
129900-23910	8	25
129900-25060	7	9
129900-25100	7	10
129900-25900	7	15
129900-32000	2	8
129900-32030	2	10
	9	6
	19	11
129900-32040	2	11
	19	12
129900-34800	9	1
129900-35000	9	7
129900-39350	9	15
129900-42001	10	1
129900-42020	10	9
	19	13
129900-42450	10	12
129900-44700	10	31
129900-49860	10	14
129900-49870	10	22
	19	14
129900-77010	17	1
129900-77330	18	25
129900-77400	17	2
129900-77440	17	3
129900-77450	17	4
129900-77460	17	6
129900-77480	17	7
129900-77500	17	8
129900-77510	17	9
129900-77520	17	10
129900-77540	17	13
129900-77550	17	14
129900-77590	17	16
129900-77610	17	15
129900-77620	17	17
129900-77640	17	18



Parts No. Index

Parts No.	Fig. No.	Ref. No.
129900-77650	17	19
129900-77710	17	20
129901-22050	8	16
129901-22950	8	33
129902-01710	3	7
129902-59810	14	32
129902-59820	14	33
129902-59830	14	34
129902-59840	14	35
129911-49020	10	39
129915-01610	3	2
129915-49010	10	38
129915-51020	11	1
129915-59120	15	32
129915-66810	16	1
129915-77050	5	5
129920-21580	8	11
129950-59311	15	25
129955-77810	16	2
129957-59040	15	7
		10
129961-59110	15	27
129980-59530	15	30
129982-53000	14	5
171008-77450	17	5
171008-77730	17	11
171008-77740	17	12
171008-77750	17	21
171051-01921	1	5
171093-44500	10	34
22117-060000	16	6
22190-060002	15	18
22190-080002	9	19
	19	24
22190-120002	15	22
	19	25
22190-140002	15	41
		42
	19	26
22190-220002	3	10
22242-000180	4	40
22252-000300	8	21
22312-080160	2	12
22351-060012	1	10
22512-070140	7	7
	8	6
22857-500100	4	49
23000-054000	10	40
23297-060081	9	16
23414-080000	9	17

Parts No.	Fig. No.	Ref. No.
23414-080000	15	24
	19	18
23857-030000	9	18
23857-060000	15	23
23871-005000	4	10
23871-030000	1	4
		11
		13
	10	20
24311-000070	2	23
	19	20
24311-000120	4	51
	19	21
24311-000320	2	27
	4	2
	19	23
24341-000240	2	25
	19	22
25132-004200	10	13
26014-080252	18	26
26106-060102	16	7
26106-060142	10	21
26106-060162	2	26
26106-060302	10	10
26106-080102	15	3
26106-080122	3	11
		9
		12
26106-080162	2	14
	4	52
	7	8
	9	13
	16	8
26106-080202	2	15
	14	3
26106-080302	2	16
26106-080352	5	6
26106-080402	2	17
		18
26106-080452	2	19
	5	3
	6	4
26106-080552	7	14
	10	11
26106-080602	10	23
26106-080702	2	20
		21
26106-080802	10	33
26106-100142	14	2
26106-100252	15	4

Parts No.	Fig. No.	Ref. No.
26106-100652	4	1
26116-120302	17	22
26206-100352	3	5
26216-060202	4	22
26216-080452	6	7
26216-100302	2	9
26366-060002	4	23
26366-080002	6	2
	18	24
26366-100002	2	13
	4	43
26577-040162	4	41
26716-060002	16	5
27225-080080	4	50
27231-550000	1	12
27241-300000	1	14
27241-400000	4	11
27310-080001	4	24
729900-01560	1	1
729900-01570	2	1
729900-11100	4	5
729900-92620	19	1
729982-53100	14	4
977770-01212	2	5
	3	4
	4	53
	19	28
X0131214140	11	96
X0141108440	12	12
X0160100540	12	62
X0160101640	12	52
X0166302030	11	68
X0166402030	11	66
X0200061640	12	26
		67
X0200062040	11	94
	12	25
X0200181840	12	6
X0201063840	12	20
X0201065040	12	18
X0258031310	12	57
X0258031610	12	28
X0265061040	12	82
X0265101340	11	2
X0265121540	12	45
X0265141840	11	100
	13	1
		15
X0265182240	12	48
X0282017020	11	69

Parts No.	Fig. No.	Ref. No.
X0282020020	11	67
X0290106810	12	8
X0290206260	12	23
		24
X0290406020	11	4
X0292312030	12	30
X0293110010	12	32
X0293110020	11	28
X0293110030	11	29
X0293110040	11	30
X0293110050	11	31
X0293110060	11	32
X0293110070	11	33
X0293110080	11	34
X0293110090	11	35
X0293110110	11	36
X0293110120	11	37
X0293110130	11	38
X0293110140	11	39
X0293110180	12	33
X0293110190	12	34
X0293110210	12	35
X0293110270	11	40
X0293110280	11	41
X0293110290	11	42
X0293110310	11	43
X0293110320	11	44
X0293110330	11	45
X0293110340	11	46
X0293110350	11	47
X0293110490	11	48
X0293110500	11	49
X0293110520	12	73
X0293110530	12	74
X0293110540	12	75
X0293110550	12	76
X0293110560	12	77
X0293110570	12	78
X0293110580	11	50
X0293110590	11	51
X0293110600	11	52
X0293110610	11	53
X0293110620	11	54
X0293110630	11	55
X0293110710	11	56
X0293111070	12	55
X0293117010	11	72
X0293117020	11	73
X0293117030	11	74
X0293117040	11	75



Parts No. Index

Parts No.	Fig. No.	Ref. No.
X0293117050	11	76
X0293117060	11	77
X0293117070	11	78
X0293117090	11	79
X0293117210	11	80
X0293117220	11	81
X0293120220	11	83
X0293120230	11	84
X0293120240	11	85
X0293120250	11	86
X0293120260	11	87
X0293120270	11	88
X0293120290	11	89
X0293120300	11	90
X0293212020	12	29
X0293214010	11	97
X0293406020	11	11
X0294704030	11	98
X0296220190	11	92
X0296310030	12	69
X0296316060	13	11
X0296318020	12	51
X0296320030	11	22
X0296325070	12	3
X0296331010	11	14
X0296352020	12	81
X0296375020	11	101
X0297310120	11	102
X0297314680	11	99
	13	14
X1310022000	11	6
		7
X1310111900	11	9
X1310171000	11	10
X1310286220	11	8
X1310341401	11	12
X1310641621	11	3
X1311123500	11	17
X1311151600	11	18
X1311167600	11	19
X1311172300	11	20
X1311220520	11	21
X1311540820	11	15
X1311607920	11	16
X1312000220	11	23
X1312030200	11	24
X1312041000	11	25
X1312050500	11	26
X1312060200	11	27
X1312152500	11	57

Parts No.	Fig. No.	Ref. No.
X1312160100	11	58
X1312170200	11	59
X1312260300	11	61
X1312400100	11	62
X1312410100	11	63
X1312420100	11	64
X1312540600	11	60
X1313020300	11	70
X1313021000	11	71
X1313211900	11	95
X1313301800	11	93
X1313612700	11	65
X1340260000	11	5
X1392060400	11	13
X1392060600	12	16
X1394100000	12	36
X1394100100	12	37
X1394103000	12	38
X1394103100	12	39
X1394103200	12	40
X1394110000	12	54
X1394170000	11	82
X1394200400	11	91
X1395260000	13	7
X1396110000	12	53
X1520300200	13	3
X1520620020	13	2
X1521002301	13	4
X1521020400	13	5
X1521051500	13	6
X1521150500	13	8
X1521160200	13	9
X1521180900	13	10
X1522006720	13	12
X1523005920	13	13
X1530205220	12	21
X1540006400	12	2
X1540070200	12	5
X1540072900	12	4
X1540100100	12	19
X1540101100	12	9
X1540110100	12	10
X1540111700	12	44
X1540132320	12	11
X1540313000	12	15
X1540351600	12	1
X1540360300	12	17
X1540635100	12	22
X1541010020	12	27
X1541230120	12	31

Parts No.	Fig. No.	Ref. No.
X1541500400	12	41
X1541540701	12	42
X1541581720	12	43
X1541591200	12	46
X1542006920	12	49
X1542043000	12	50
X1542043100	12	56
X1542060200	12	59
X1542062800	12	58
X1542163820	12	60
X1542303920	12	61
X1542364100	12	63
X1542370100	12	64
X1543142600	12	68
X1543210400	12	14
X1543220100	12	70
X1543265020	12	71
X1543277400	12	72
X1543501900	12	7
X1543507700	12	79
X1543507800	12	80
X1543587200	12	47
X1543829320	12	66
X1543956420	12	65
X1545001020	12	13

Parts No.	Fig. No.	Ref. No.
-----------	----------	----------