

OCR10-M75000EN

# Introduction

1. This parts catalog is a first edition of the 4JH5E Diesel engine.

	Parts catalog No.	Date of issue	Remarks
First edition	OCR10-G75000	Dec. , 2008	

2. Standard finish color.

	Yanmar ecole silver metallic
Parts No. 977620-10070	1L (Packed in a can)
Parts No. 977620-40070	4L (Packed in a can)
Parts No. TOR-90090003	Spray (1 piece)

3. This parts catalog does not contain the technical data needed for maintenance service.

4. The illustrations used in this parts catalog have been simplified for clarity.

5. The contents of this parts catalog are subject to change without notice.

6. Be sure to use only Yanmar genuine part for repairs. If imitation parts are used, it may cause engine defects.

Fig. No.	Fig. Name	Fig. No.	Fig. Name
4JH5E		25.	FUEL FEED PUMP
1.	CYLINDER BLOCK	26.	FUEL INJECTION VALVE
2.	GEAR HOUSING	27.	FUEL INJECTION PIPE
3.	FLYWHEEL HOUSING	28.	FUEL PIPE & FUEL STRAINER
4.	MOUNTING FOOT	29.	OIL/WATER SEPARATER
5.	LUB. OIL SUMP	30.	FUEL TANK(OPTIONAL)
6.	LABEL	31.	CABLE SUPPORT
7.	CYLINDER HEAD	32.	CLUTCH
8.	BONNET	33.	COUPLING(OPTIONAL)
9.	SUCTION MANIFOLD	34.	STARTER MOTOR
10.	MIXING ELBOW	35.	GENERATOR(12V-80A)(HITACHI: TO E14235)
11.	CAMSHAFT	48.	(35A)GENERATOR(12V-120A)(VALEO: FROM E14236)
12.	CRANKSHAFT & FLYWHEEL	36.	V-BELT COVER
13.	PISTON & CONNECTING ROD	37.	V-BELT COVER & GENERATOR ATTACHMENT PARTS(OPTIONAL)
14.	LUB. OIL SYSTEM	38.	WIRE HARNESS & SENSOR
15.	LUB. OIL PIPE	50.	(38A)ELECTRICAL PARTS
16.	COOLING SEA WATER PUMP	39.	INSTRUMENT PANEL(B-TYPE/OPTIONAL)
17.	COOLING FRESH WATER PUMP	40.	INSTRUMENT PANEL(C-TYPE/OPTIONAL)
18.	COOLING FRESH WATER COOLER	41.	INSTRUMENT PANEL(B-TYPE/KEYLES/OPTIONAL)
19.	COOLING SEA WATER PIPE	42.	INSTRUMENT PANEL(C-TYPE/KEYLES/OPTIONAL)
20.	COOLING FRESH WATER PIPE	46.	(42A)INSTRUMENT PANEL(B20)(MEDALLION/FROM JAN., 2012)
21.	COOLING FILTER(SEA WATER)(OPTIONAL)	47.	(42B)INSTRUMENT PANEL(C30)(MEDALLION/FROM JAN., 2012)
22.	BILGE PUMP(OPTIONAL)	43.	TOOL
23.	FUEL INJECTION PUMP	44.	GASKET SET(OPTIONAL)
24.	GOVERNOR	45.	GENERATOR(ADDITION) & GENERATOR MOUNT PART(OPTIONAL)



Fig. No.	Fig. Name
49.	S2 DRIVE(OPTIONAL)

Fig. No.	Fig. Name
----------	-----------



(A)=4JH5E

(B)=

(C)=

(D)=

(E)=

(F)=

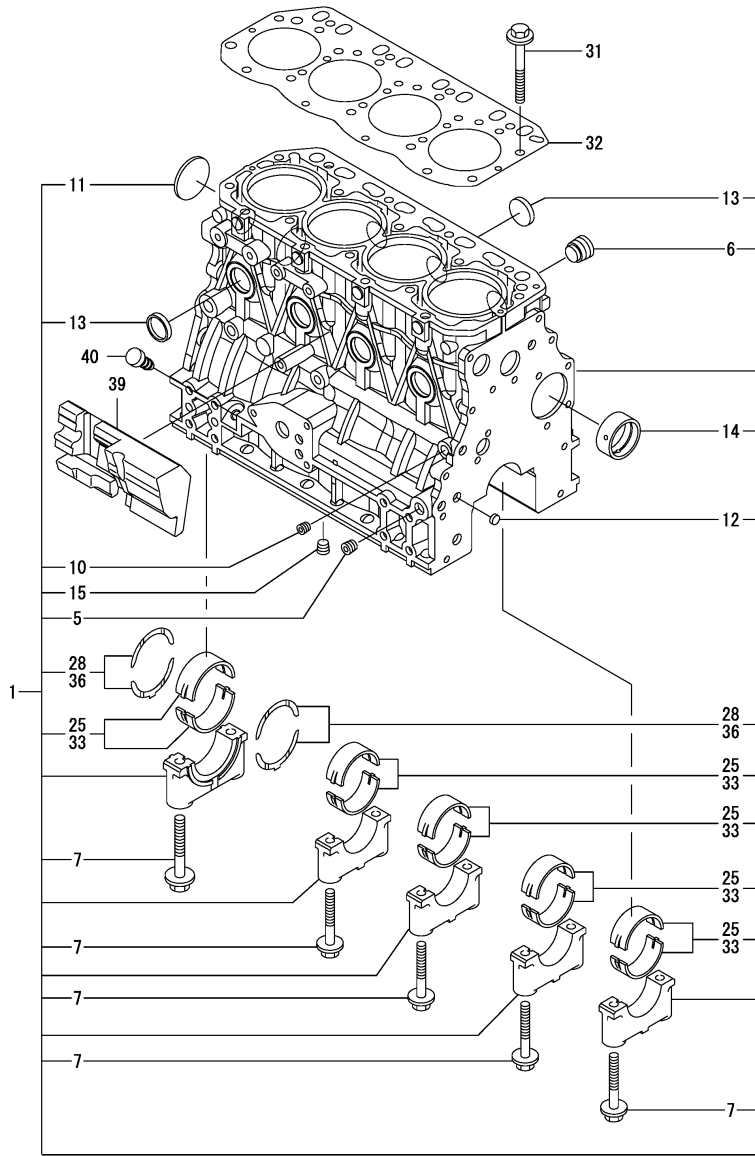

No.	Lev.	Parts No.	Description	Q'ty						I	R
				(A)	(B)	(C)	(D)	(E)	(F)		
1	1	729602-01560	BLOCK ASSY, CYLINDER	1							
5	3	124160-01910	PLUG, PT1/4	2							
6	3	171051-01921	PLUG, NPTF1	1							
7	3	129150-02020	BOLT, METAL CAP	10							
10	3	124060-01050	PLUG, PT1/8	1							
11	3	129001-01250	PLUG, 50	1							
12	3	27241-120000	PLUG, 12	2							
13	3	27241-300000	PLUG 30	8							
14	3	129795-02412	BUSH, CAMSHAFT	1							
15	3	124160-01910	PLUG, PT1/4	1							
25	2	129001-02931	BEARING, MAIN	5							3
28	2	129150-02931	BEARING, THRUST	2							3
31	1	129150-01200	BOLT, HEAD	18							
32	1	129407-01340	GASKET, HEAD	1							
33	1	129150-02871	BEARING, 0.25 US	5							1
36	1	129150-02941	BEARING, THRUST 0.25	1							2
39	1	129004-01190	SPACER	1							
40	1	124976-34850	CAP	1							

## Remarks

- (1) UNDER SIZED (U.S.=0.25) PART.
- (2) OVER SIZED (O.S.=0.25) PART.
- (3) REPAIR PART.

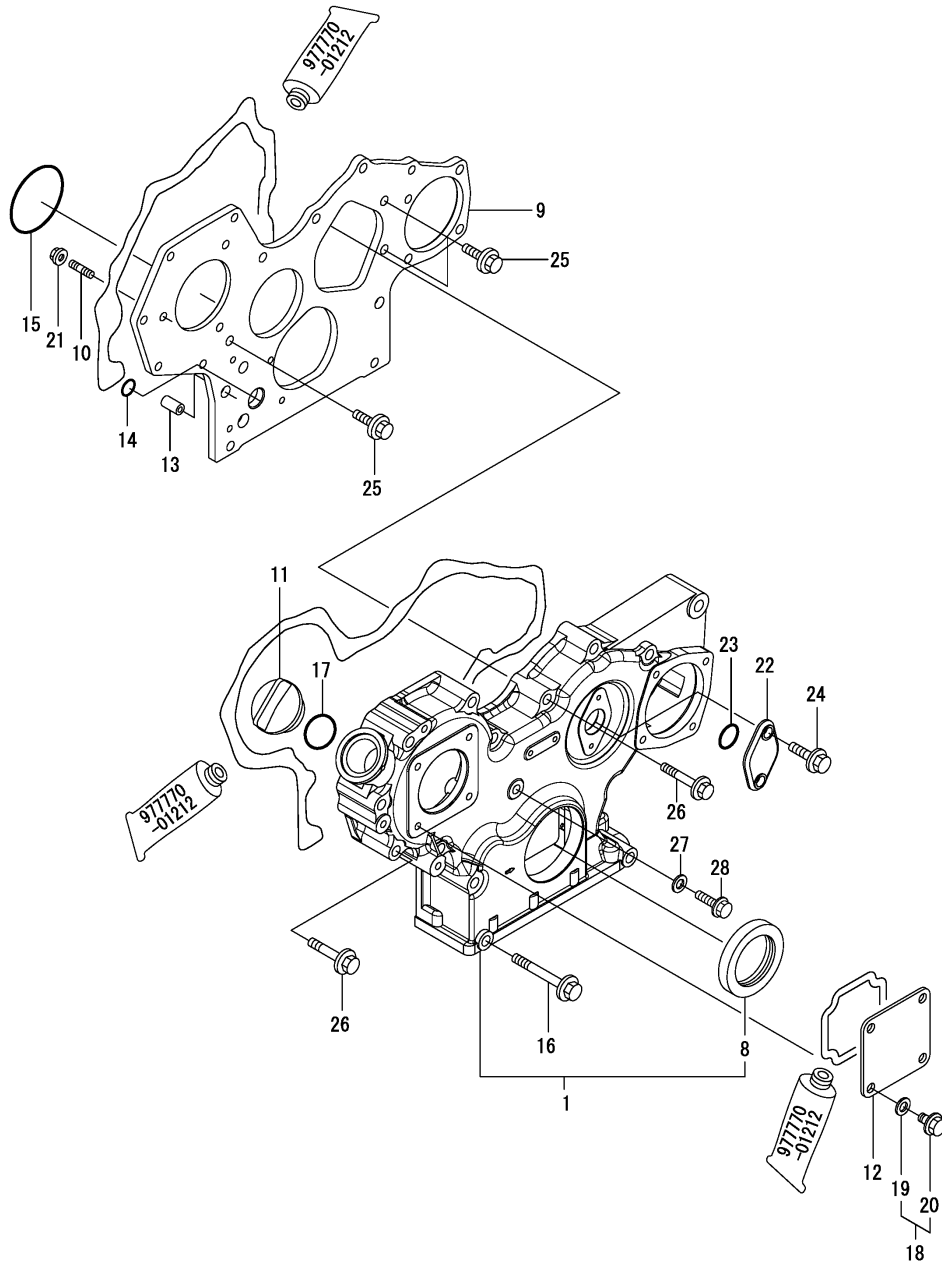

(A)=4JH5E  
(B)=  
(C)=

(D)=  
(E)=  
(F)=

No.	Lev.	Parts No.	Description	Q'ty						I	R
				(A)	(B)	(C)	(D)	(E)	(F)		
1	1	129271-01600	CASE ASSY, GEAR	1							
8	2	119934-01800	SEAL, OIL	1							
9	1	129008-01520	FLANGE, GEAR CASE	1							
10	1	119802-01561	STUD, M8X25	3							
11	1	124160-01751	COVER, FILLER	1							
12	1	124240-01871	COVER	1							
13	1	129795-01950	PIPE, KNOCK L=18	2							
14	1	119609-32040	O-RING, P16	2							
15	1	121850-51960	O-RING	1							
16	1	26106-080852	BOLT, M8X 85 PLATED	3							
17	1	24311-000320	O-RING, 1AP32.0	1							
18	1	124550-01590	BOLT, M8X16	4							
19	2	22190-080002	WASHER, SEAL 6	4							
20	2	26106-080162	BOLT, M8X 16 PLATED	4							
21	1	26306-080002	NUT, M8	3							
22	1	121023-01551	COVER	1							
23	1	24341-000240	O-RING, 1AS24.0	1							
24	1	26106-060162	BOLT, M6X 16 PLATED	2							
25	1	26106-080162	BOLT, M8X 16 PLATED	3							
26	1	26106-080552	BOLT, M8X 55 PLATED	10							
27	1	22190-080002	WASHER, SEAL 6	1							
28	1	26106-080302	BOLT, M8X 30 PLATED	1							

(A)=4JH5E  
(B)=  
(C)=

(D)=  
(E)=  
(F)=

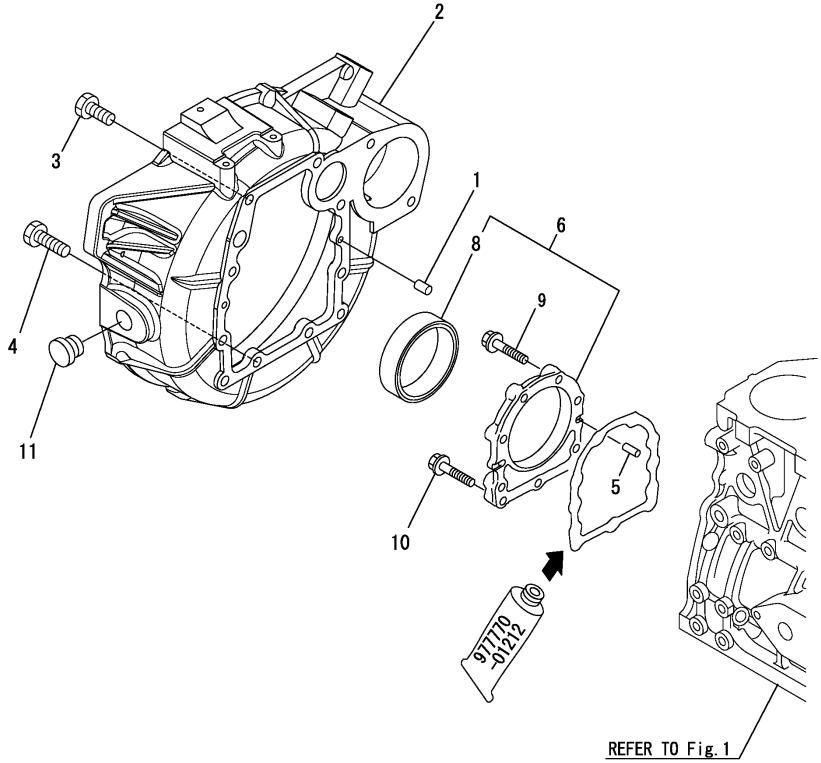

No.	Lev.	Parts No.	Description	Q'ty						I	R
				(A)	(B)	(C)	(D)	(E)	(F)		
1	1	129100-01580	PIN, M8X16	2							
2	1	129670-01600	HOUSING, FLYWHEEL	1							
3	1	26206-100252	BOLT, M10X 25 PLATED	6							
4	1	26206-100302	BOLT, M10X 30 PLATED	4							
5	1	129100-01580	PIN, M8X16	2							
6	1	129100-01640	CASE ASSY, OIL SEAL	1							
8	2	129795-01780	SEAL, OIL	1							
9	1	129486-01670	BOLT, M8X30	6							
10	1	26106-080352	BOLT, M8X 35 PLATED	3							
11	1	119620-01750	CAP	1							

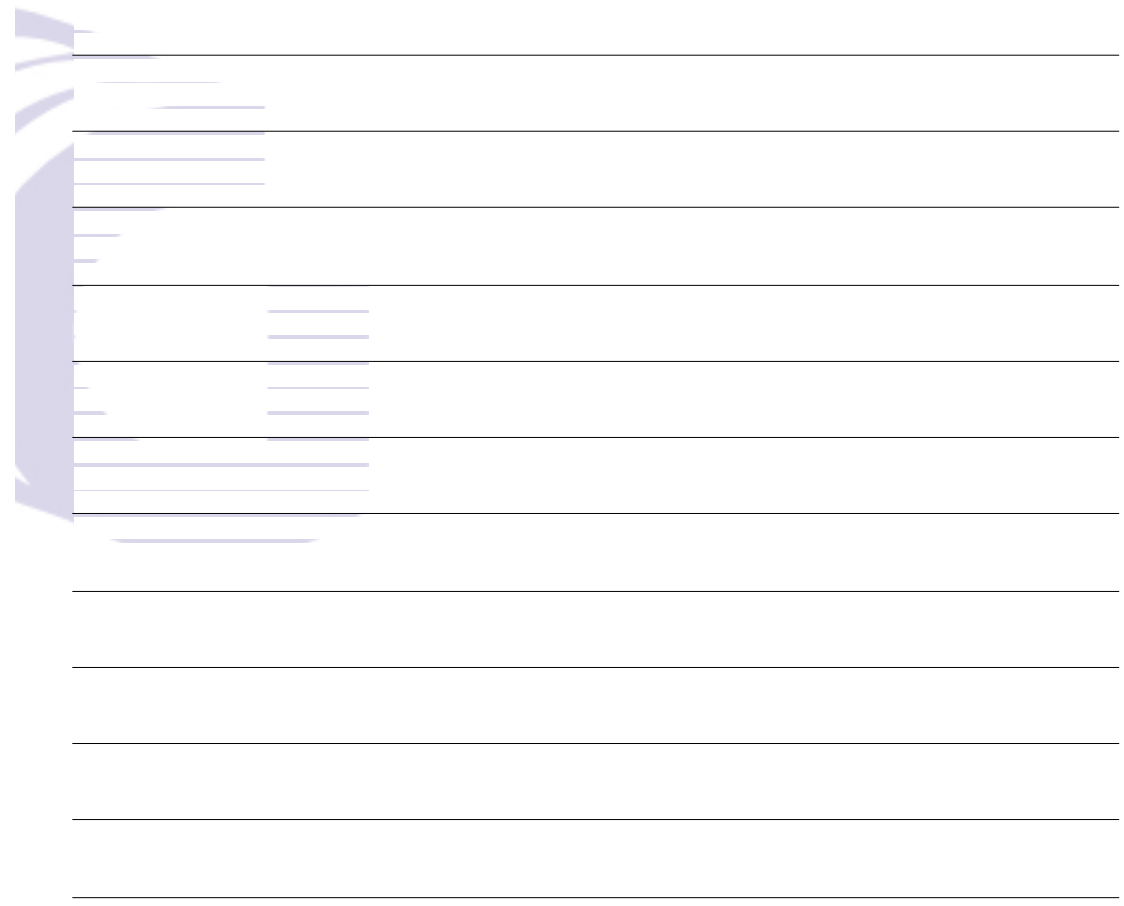

(A)=4JH5E  
(B)=  
(C)=

(D)=  
(E)=  
(F)=

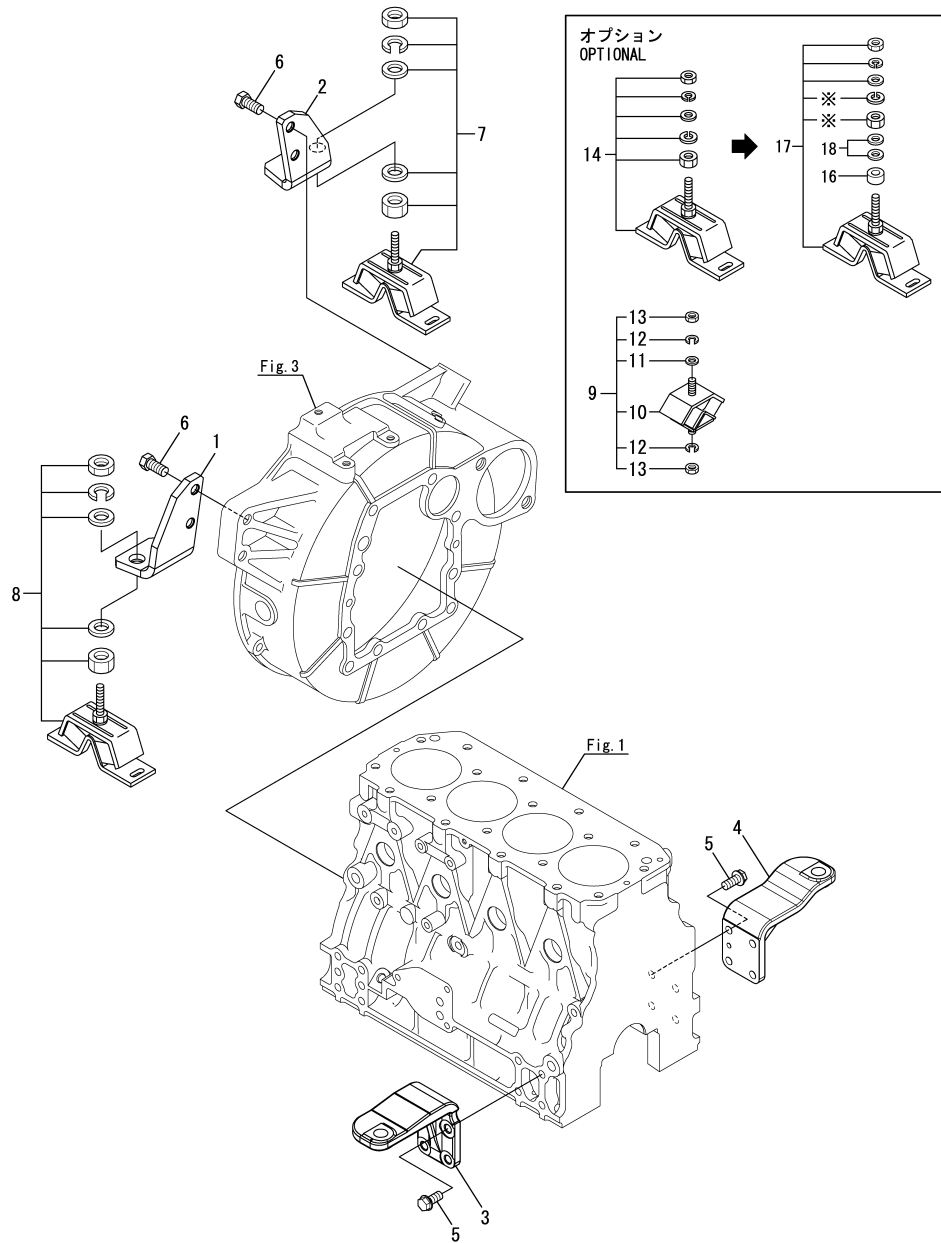

No.	Lev.	Parts No.	Description	Q'ty						I	R
				(A)	(B)	(C)	(D)	(E)	(F)		
1	1	129670-08231	FOOT, MOUNTING C	1							
2	1	129670-08241	FOOT, MOUNTING D	1							
3	1	129670-08211	FOOT, MOUNTING A	1							
4	1	129670-08220	FOOT, MOUNTING B	1							
5	1	26106-100222	BOLT, M10X 22 PLATED	8							
6	1	26116-120252	BOLT, M12X 25 PLATED	4							
7	1	129670-08350	MOUNT, FLEXIBLE 200	2							
7-1	1	129670-08351	MOUNT, FLEXIBLE 200	4							R
(A=E/#E16663)											
7-2	1	129470-08350	MOUNT, FLEXIBLE 200	4							R
(A=*2020.04)											
8	1	129670-08340	MOUNT, FLEXIBLE 150	2							
8-1	1	129670-08341	MOUNT, FLEXIBLE 150	2							R
(A=E/#E16663)											
8-2	1	121370-08351	MOUNT, FLEXIBLE 150	2							R
(A=*2020.04)											
9	1	796440-08630	RUBBER ASSY,CUSHION	1							
10	2	196440-02380	RUBBER, ABSORBER 430	1							
11	2	196440-02390	WASHER	1							
12	2	22217-120000	WASHER, SPRING 12	2							
13	2	26716-120002	NUT, M12	2							
14	1	120149-08431	MOUNT, FLEXIBLE 250	2							Z
(A=*2012.12)											
16	1	129671-08250	SPACER, ABSORBER	2							W
(A=*2012.12)											
17	1	120149-08431	MOUNT, FLEXIBLE 250	2							W
(A=*2012.12)											
18	1	22137-160000	WASHER, 16	2							W
(A=*2012.12)											

Remarks  
\* They are unnecessary parts.



(A)=4JH5E  
(B)=  
(C)=

(D)=  
(E)=  
(F)=

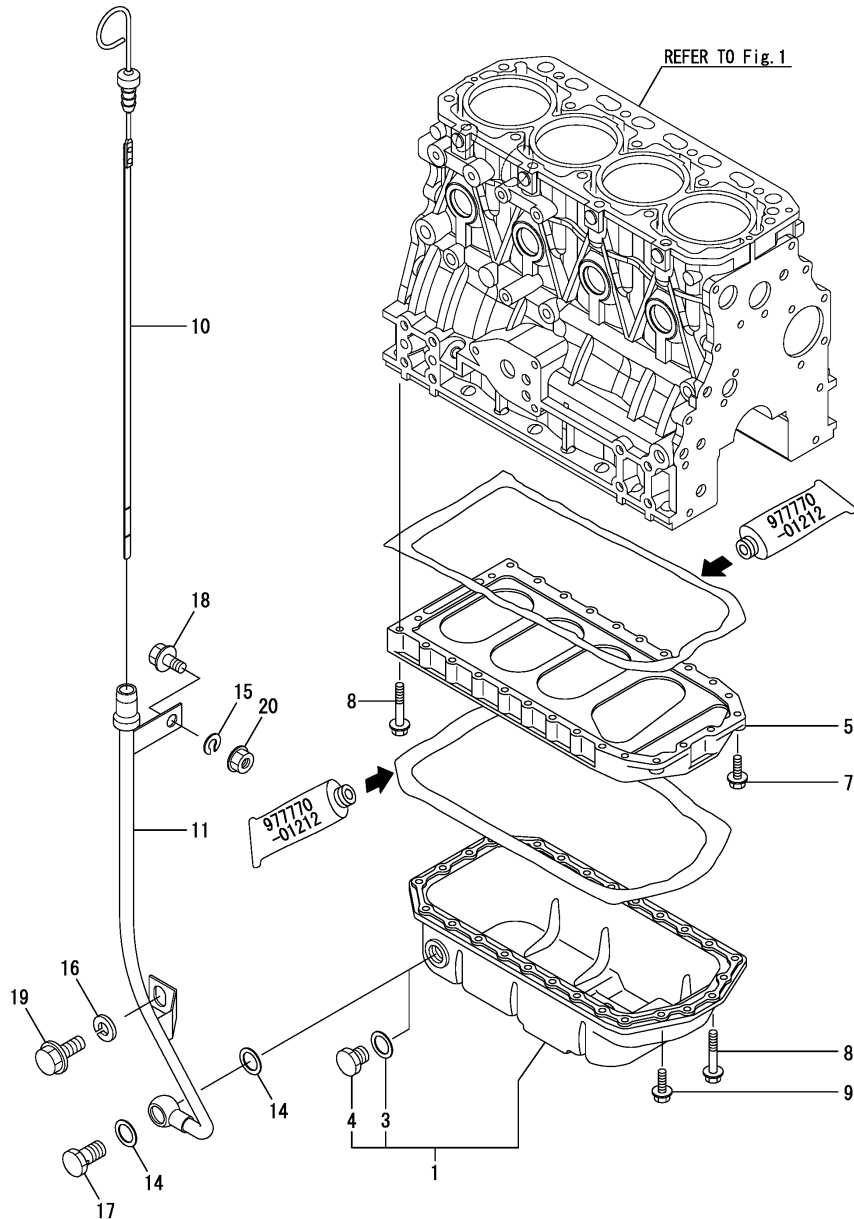

No.	Lev.	Parts No.	Description	Q'ty						I	R
				(A)	(B)	(C)	(D)	(E)	(F)		
1	1	129670-01700	SUMP, OIL	1							
3	2	23414-140000	GASKET, 14X1.0	1							
4	2	23887-140002	PLUG M14	1							
5	1	129400-01730	SPACER, OIL SUMP	1							
7	1	26106-080252	BOLT, M8X 25 PLATED	2							
8	1	26106-080452	BOLT, M8X 45 PLATED	24							
9	1	26106-080162	BOLT, M8X 16 PLATED	4							
10	1	129670-34800	DIPSTICK, OIL	1							
11	1	129271-34880	GUIDE ASSY, DIPSTICK	1							
14	1	22190-140002	WASHER, SEAL 14	2							
15	1	22217-080000	WASHER, SPRING 8	1							
16	1	22217-100000	WASHER, SPRING 10	1							
17	1	23851-080000	JOIT BOLT 8	1							
18	1	26106-080162	BOLT, M8X 16 PLATED	1							
19	1	26106-100162	BOLT, M10X 16 PLATED	1							
20	1	26306-080002	NUT, M8	1							

(A)=4JH5E

(B)=

(C)=

(D)=

(E)=

(F)=

No.	Lev.	Parts No.	Description	Q'ty						I	R
				(A)	(B)	(C)	(D)	(E)	(F)		
1	1	128377-07150	LABEL, CAUTION	1							
2	1	128377-07260	LABEL, PRESSURE CAP	1							
3	1	128377-07350	LABEL, CAUTION	1							
4	1	123682-07852	LABEL, CAUTION	1							
5	1	177088-02430	LABEL	1							
6	1	128377-07190	LABEL, LOOSE PARTS	1							
7	2	128377-07400	LABEL, DANGER	2							
8	2	128377-07420	LABEL, DANGER	1							
9	2	128377-07450	LABEL, CAUTION	1							
10	2	128377-07460	LABEL, CAUTION	1							
11	1	177073-02431	LABEL, DIRECTION	1							
12	1	196630-12980	LABEL, CAUTION	1							

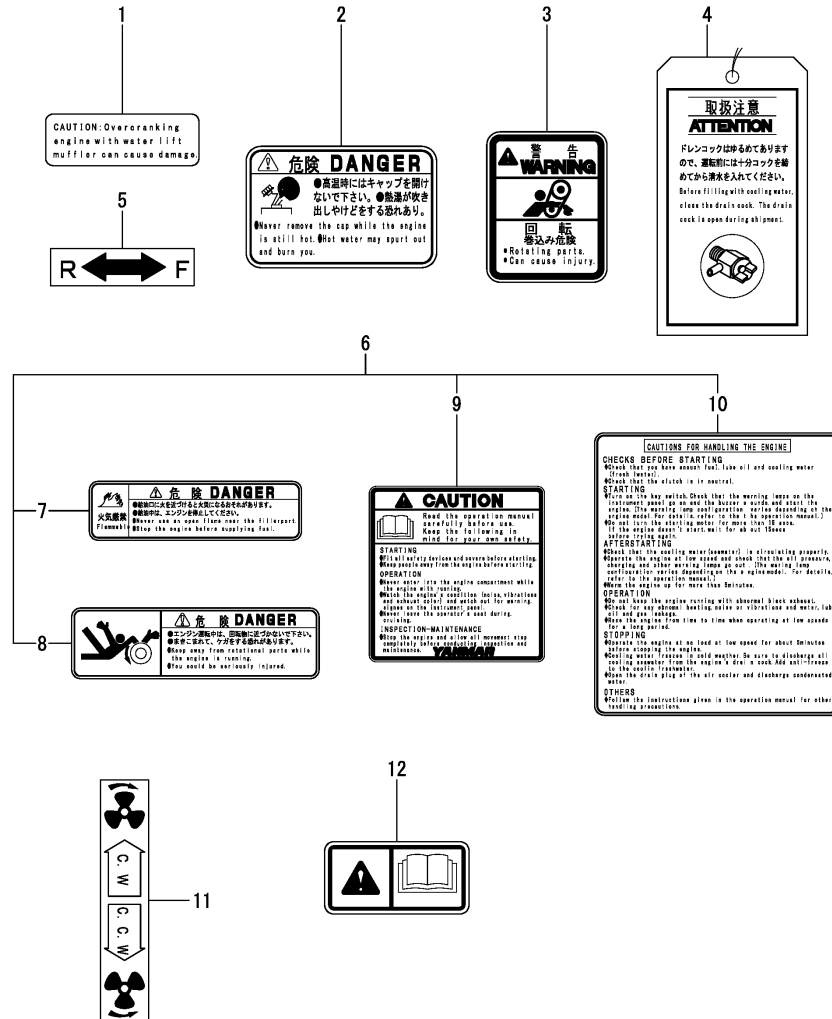

(A)=4JH5E  
(B)=  
(C)=

(D)=  
(E)=  
(F)=

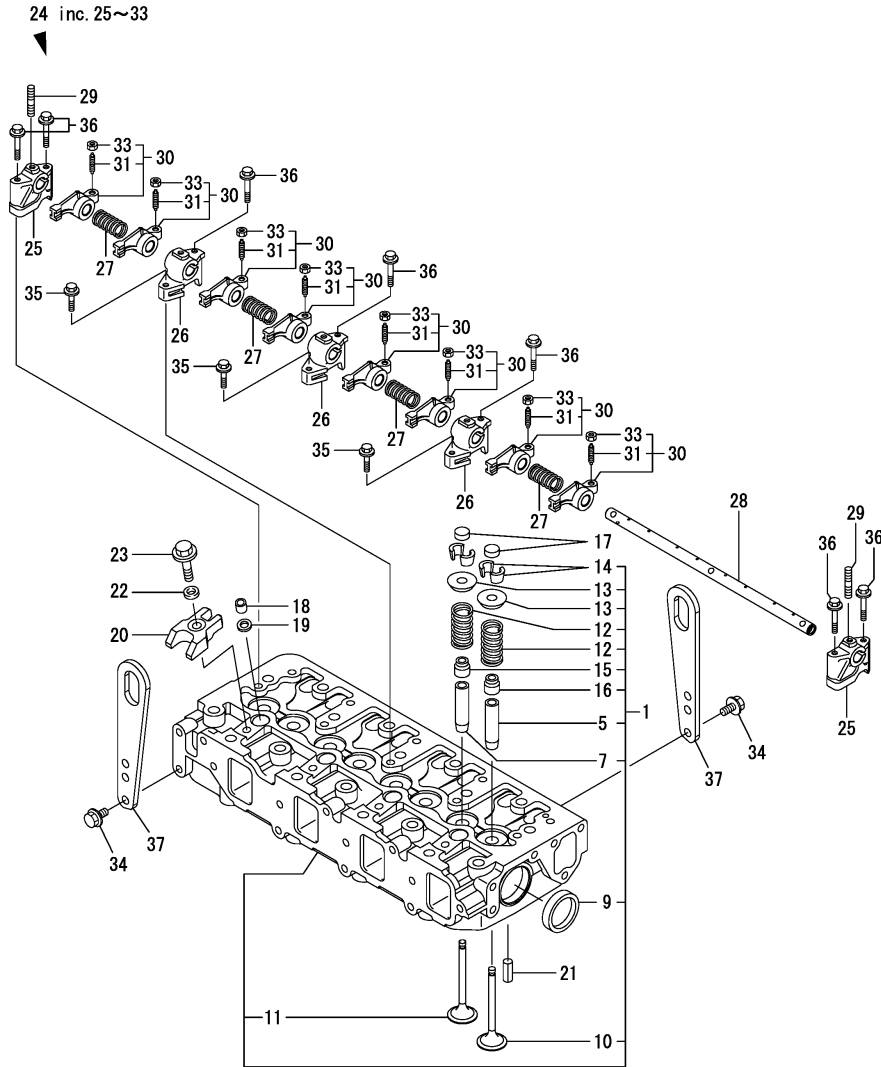

No.	Lev.	Parts No.	Description	Q'ty						I	R
				(A)	(B)	(C)	(D)	(E)	(F)		
1	1	129602-11700	HEAD ASSY, CYLINDER	1							
5	2	120130-11860	GUIDE, VALVE	4							1
7	2	129150-11810	GUIDE, VALVE	4							1
9	2	27241-400000	PLUG, 40	2							
10	2	129005-11100	VALVE, INTAKE	4							
11	2	129100-11112	VALVE, EXHAUST	4							
12	2	129795-11120	SPRING, VALVE	8							
13	2	129795-11180	RETAINER, SPRING	8							
14	2	27310-080001	COTTER, 8	8							
15	2	121400-11340	SEAL, VALVE STEM	4							
16	2	124460-11340	SEAL, VALVE STEM	4							
17	1	129150-11370	CAP, VALVE	8							
18	1	119802-11870	PROTECTOR, NOZZLE	4							
19	1	119625-11880	SEAT, NOZZLE	4							
20	1	129004-11900	RETAINER, NOZZLE	4							
21	1	22351-060012	PIN, SPRING 6.0X12	2							
22	1	120270-54410	WASHER, INJECTOR	4							
23	1	26106-080352	BOLT, M8X 35 PLATED	4							
24	1	129601-11241	SHAFT ASSY, ROCKER	1							
25	2	119802-11260	SUPPORT, ROCKER ARM	2							
26	2	119802-11270	SUPPORT, ROCKER ARM	3							
27	2	129150-11280	SPRING	4							
28	2	129601-11251	SHAFT, ROCKER ARM	1							
29	2	26226-080182	STUD, M8X 18	3							
30	2	129004-11650	ARM, ROCKER	8							
31	3	129150-11230	SCREW, VALVE ADJUST	8							
33	3	129150-11750	NUT, M8	8							
34	1	26106-080162	BOLT, M8X 16 PLATED	4							
35	1	26106-080252	BOLT, M8X 25 PLATED	3							
36	1	26106-080502	BOLT, M8X 50 PLATED	7							
37	1	129900-07900	LIFTER	2							

Remarks

(1)REPAIR PART.

(A)=4JH5E  
(B)=  
(C)=

(D)=  
(E)=  
(F)=

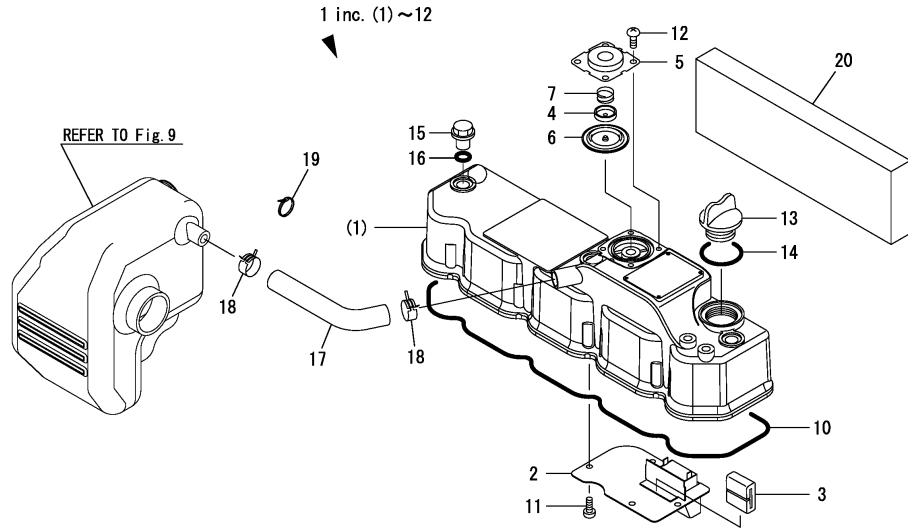

No.	Lev.	Parts No.	Description	Q'ty						I	R
				(A)	(B)	(C)	(D)	(E)	(F)		
1	1	129601-11350	BONNET ASSY, HEAD	1							
2	2	129004-03010	PLATE	1							
3	2	129150-03070	BAFFLE, BREATHER	1							
4	2	119802-03110	PLATE	1							
5	2	119802-03121	COVER, DIAPHRAGM	1							
6	2	119802-03130	DIAPHRAGM	1							
7	2	119802-03141	SPRING, DIAPHRAGM	1							
10	2	129601-11310	GASKET, BONNET	1							
11	2	22857-500100	SCREW, 5X10	4							
12	2	22857-500100	SCREW, 5X10	4							
13	1	124160-01751	COVER, FILLER	1							
14	1	24311-000320	O-RING, 1AP32.0	1							
15	1	124160-11360	KNOB	3							
16	1	24311-000120	O-RING, 1AP12.0	3							
17	1	129670-03090	PIPE, BREATHER	1							
17-1	1	129670-03091	PIPE, BREATHER	1						S	1
(A=EZZZZZ)											
18	1	129410-03990	CLIP	2							
18-1	1	124398-49700	CLIP, HOSE 24.0	2						S	1
(A=EZZZZZ)											
19	1	121750-59890	BAND, 140	1							
20	1	129670-11960	INSULATOR, NOISE	1							

Remarks

(1)Interchangeable by simultaneous replacement with Ref.No.17-1,18-1.

(A)=4JH5E  
(B)=  
(C)=

(D)=  
(E)=  
(F)=

No.	Lev.	Parts No.	Description	Q'ty						I	R
				(A)	(B)	(C)	(D)	(E)	(F)		
1	1	129698-12100	MANIFOLD ASSY,INTAKE	1							
3	2	129470-12120	COVER, MANIFOLD	1							
4	2	23414-100000	GASKET, 10X1.0	1							
5	2	23887-100002	PLUG, 10	1							
6	2	26476-060142	SCREW, TAPPING M6X14	18							
7	1	129470-12130	GASKET, MANIFOLD	1							
8	1	22190-080002	WASHER, SEAL 6	1							
9	1	26106-080122	BOLT, M8X 12 PLATED	1							
10	1	26106-080202	BOLT, M8X 20 PLATED	5							
11	1	129120-77502	HEATER	1							
12	1	129150-77511	GASKET	1							
13	1	26106-080352	BOLT, M8X 35 PLATED	4							
14	1	129271-12311	SILENCER	1							
15	1	129670-12360	PIPE, SILENCER	1							
16	1	129670-12410	BRACKET, SILENCER	1							
17	1	129271-12810	PIPE,SUC AIR	1							
18	1	128990-77430	COLLAR	1							
19	1	23000-060000	CLAMP, 60	2							
20	1	23000-048000	CLAMP, 48	1							
21	1	26106-080162	BOLT, M8X 16 PLATED	2							

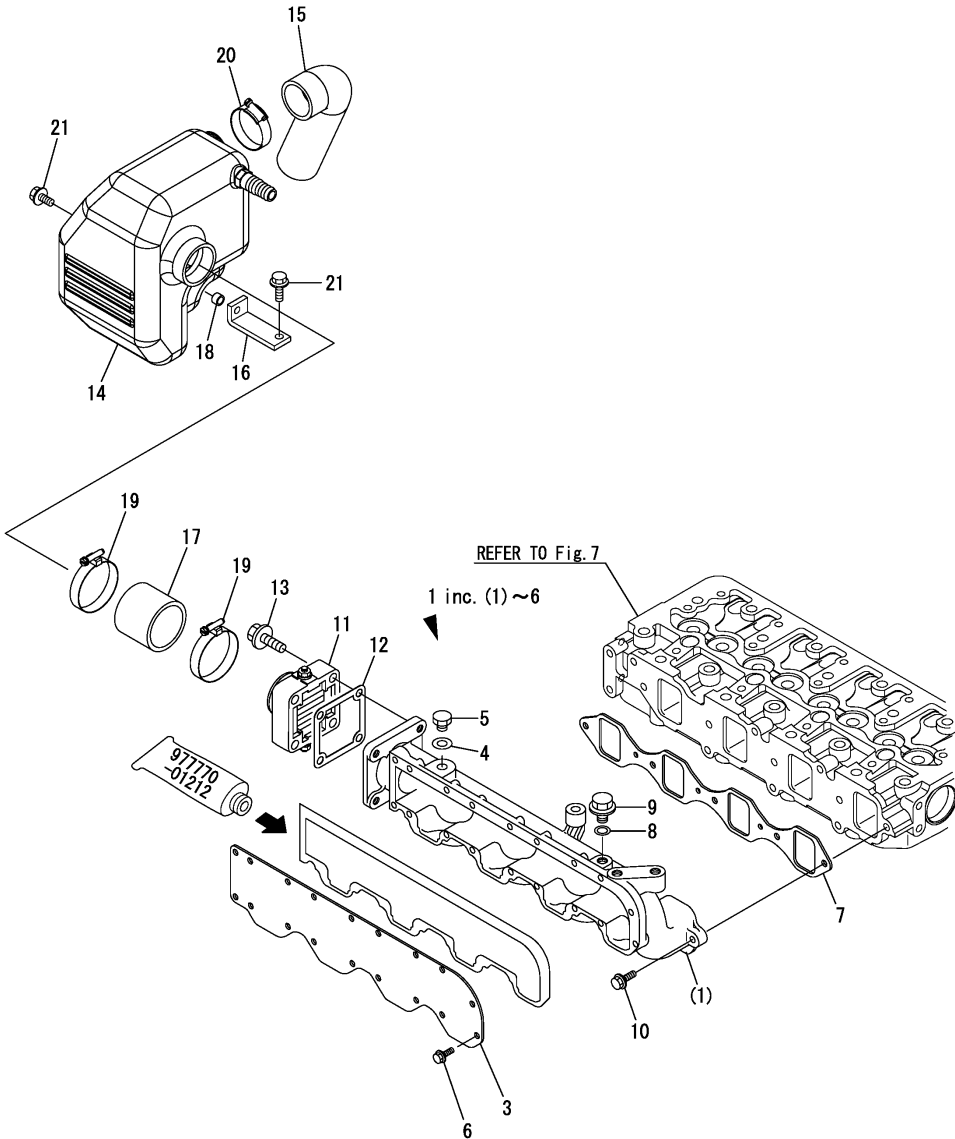

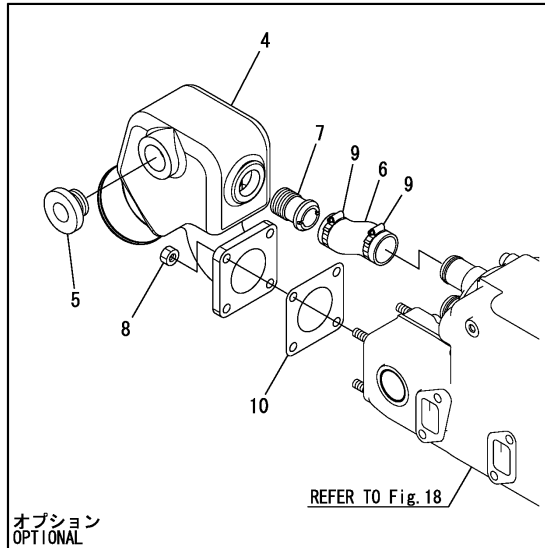
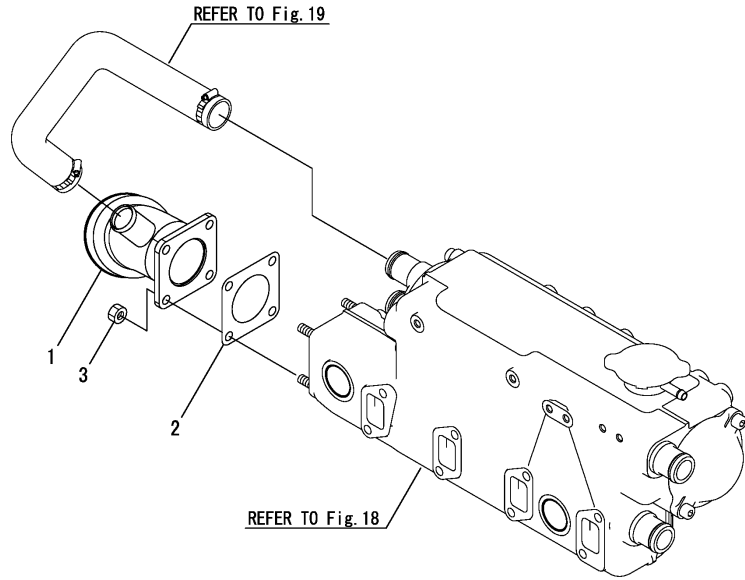

(A)=4JH5E  
(B)=  
(C)=

(D)=  
(E)=  
(F)=

No.	Lev.	Parts No.	Description	Q'ty						I	R
				(A)	(B)	(C)	(D)	(E)	(F)		
1	1	129670-13561	ELBOW	1							
2	1	129472-18090	GASKET	1							
3	1	26703-080002	NUT, M8	4							
4	1	129470-13541	ELBOW	1							
5	1	129472-13560	PLUG, PT3/4	1							
6	1	129670-49280	PIPE, WATER	1							
7	1	123325-49421	JOINT, PIPE	1							
8	1	26703-080002	NUT, M8	4							
9	1	129670-49500	CLIP, HOSE 38	2							
10	1	129472-18090	GASKET	1							

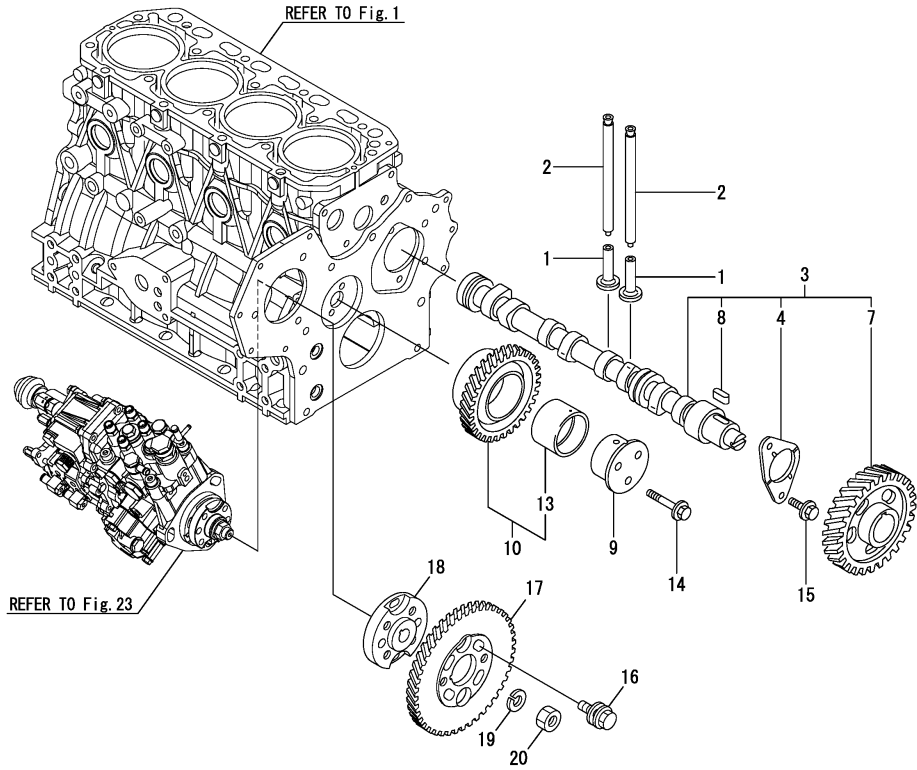

(A)=4JH5E  
(B)=  
(C)=

(D)=  
(E)=  
(F)=

No.	Lev.	Parts No.	Description	Q'ty						I	R
				(A)	(B)	(C)	(D)	(E)	(F)		
1	1	129150-14200	TAPPET	8							
2	1	129150-14400	ROD, PUSH L=178	8							
3	1	729402-14580	CAMSHAFT ASSY	1							
4	2	129150-02450	BEARING, THRUST	1							
7	2	129150-14101	GEAR, CAMSHAFT	1							
8	2	22512-070140	KEY, 7X 14	1							
9	1	119803-25050	SHAFT, IDLE	1							
10	1	119802-25101	GEAR ASSY, IDLE	1							
13	2	119802-25071	BUSH, IDLE GEAR	1							1
14	1	26106-080402	BOLT, M8X 40 PLATED	3							
15	1	26106-080142	BOLT, M8X 14 PLATED	2							
16	1	129150-25301	BOLT	4							
17	1	119802-25901	GEAR, PUMP	1							
18	1	158552-51151	FLANGE	1							
19	1	22217-140000	WASHER, SPRING 14	1							
20	1	26776-140002	NUT, LOCK M14	1							

Remarks  
(1)REPAIR PART.

(A)=4JH5E  
(B)=  
(C)=

(D)=  
(E)=  
(F)=

No.	Lev.	Parts No.	Description	Q'ty						I	R
				(A)	(B)	(C)	(D)	(E)	(F)		
1	1	129604-21000	CRANKSHAFT ASSY	1							
2	2	129100-01580	PIN, M8X16	1							
5	2	119803-21200	GEAR, CRANKSHAFT	1							
6	2	22512-070140	KEY, 7X 14	1							
8	1	22351-030010	PIN, SPRING 3.0X10	1							
9	1	119802-21660	V-PULLEY, 120	1							
10	1	129795-21661	WASHER	1							
11	1	121850-21680	BOLT	1							
12	1	121111-21501	BOLT, FLYWHEEL	6							
13	1	129670-21591	FLYWHEEL ASSY	1							
16	2	119865-21600	GEAR, RING	1							
17	1	177090-03500	DISK, DAMPER D190	1							
18	1	26106-080162	BOLT, M8X 16 PLATED	6							
19	1	196440-04310	COUPLING, 250 SP10	1							
20	1	26106-080202	BOLT, M8X 20 PLATED	6							
21	1	177070-03520	DISK, DAMPER D190	1							
22	1	26106-080162	BOLT, M8X 16 PLATED	6							
23	1	129673-81250	DISK, DAMPER	1							
24	1	26106-080252	BOLT, M8X 25 PLATED	6							
25	1	129670-81850	FAN, FLYWHEEL	1							
26	1	22217-080000	WASHER, SPRING 8	6							
27	1	26106-080162	BOLT, M8X 16 PLATED	6							
28	1	129271-21660	PULLEY, CRANK 6PK	1							W 1
(A=E14236)											
29	1	26106-100202	BOLT, M10X 20 PLATED	3							W 1
(A=E14236)											
30	1	22137-100000	WASHER, 10	3							W 1
(A=E14236)											

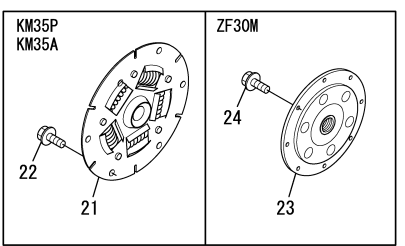
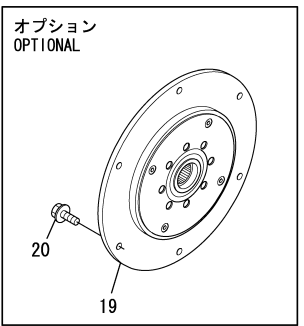
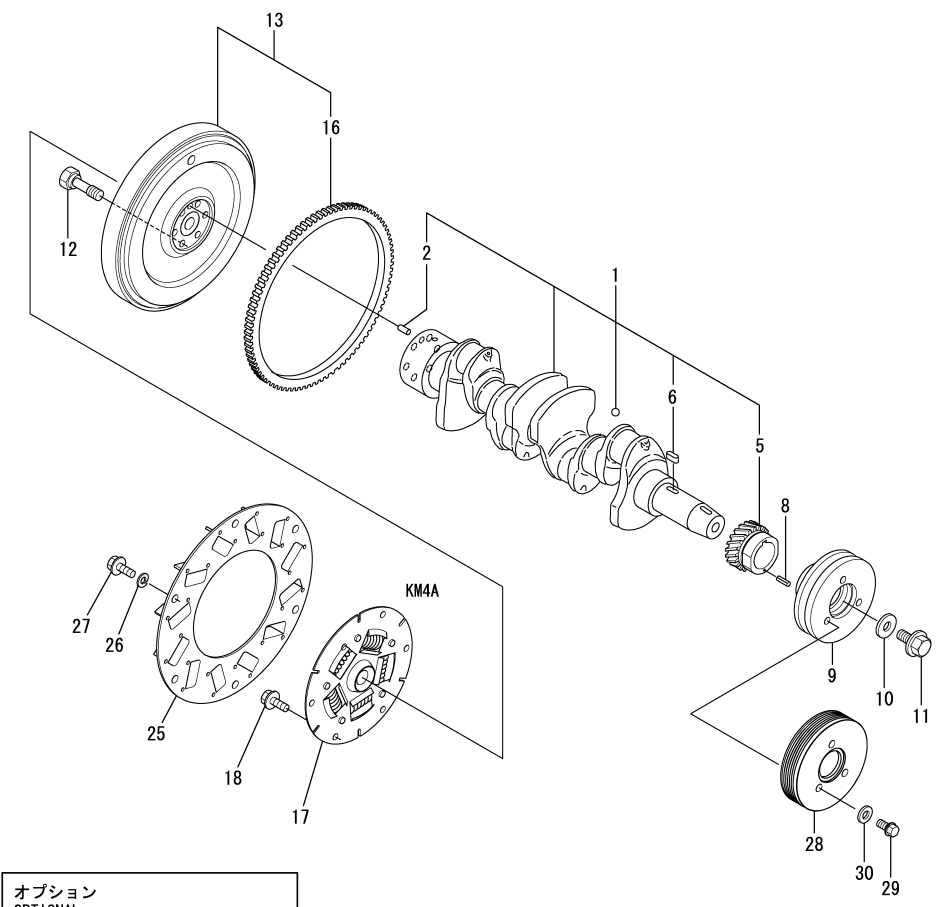

Remarks  
(1)Valeo generator spec.



(A)=4JH5E  
(B)=  
(C)=

(D)=  
(E)=  
(F)=

No.	Lev.	Parts No.	Description	Q'ty						I	R
				(A)	(B)	(C)	(D)	(E)	(F)		
1	1	129670-22020	PISTON ASSY	4							
3	2	129005-22500	RING SET, PISTON	4							
7	1	129202-22300	PIN, PISTON D26 L70	4							
8	1	22252-000260	RING, 26	8							
9	1	729402-23100	ROD ASSY, CONNECTING	4							
13	2	121550-23200	BOLT, CONNECTING ROD	8							
14	2	129150-23601	BEARING, CRANK PIN	4							
16	1	129100-23910	BEARING, PISTON PIN	4							1
17	1	129150-23611	BEARING, 0.25 US	4							3
19	1	129005-22900	PISTON ASSY, 0.25 OS	4							2
21	2	129005-22950	RING SET, 0.25 OS	4							2

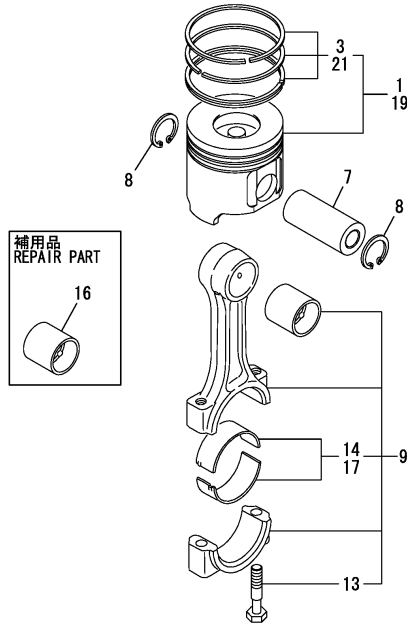

Remarks

- (1)REPAIR PART.
- (2)OVER-SIZE(O.S=0.25)PART.
- (3)UNDER-SIZE(U.S=0.25)PART.

(A)=4JH5E

(B)=

(C)=

(D)=

(E)=

(F)=

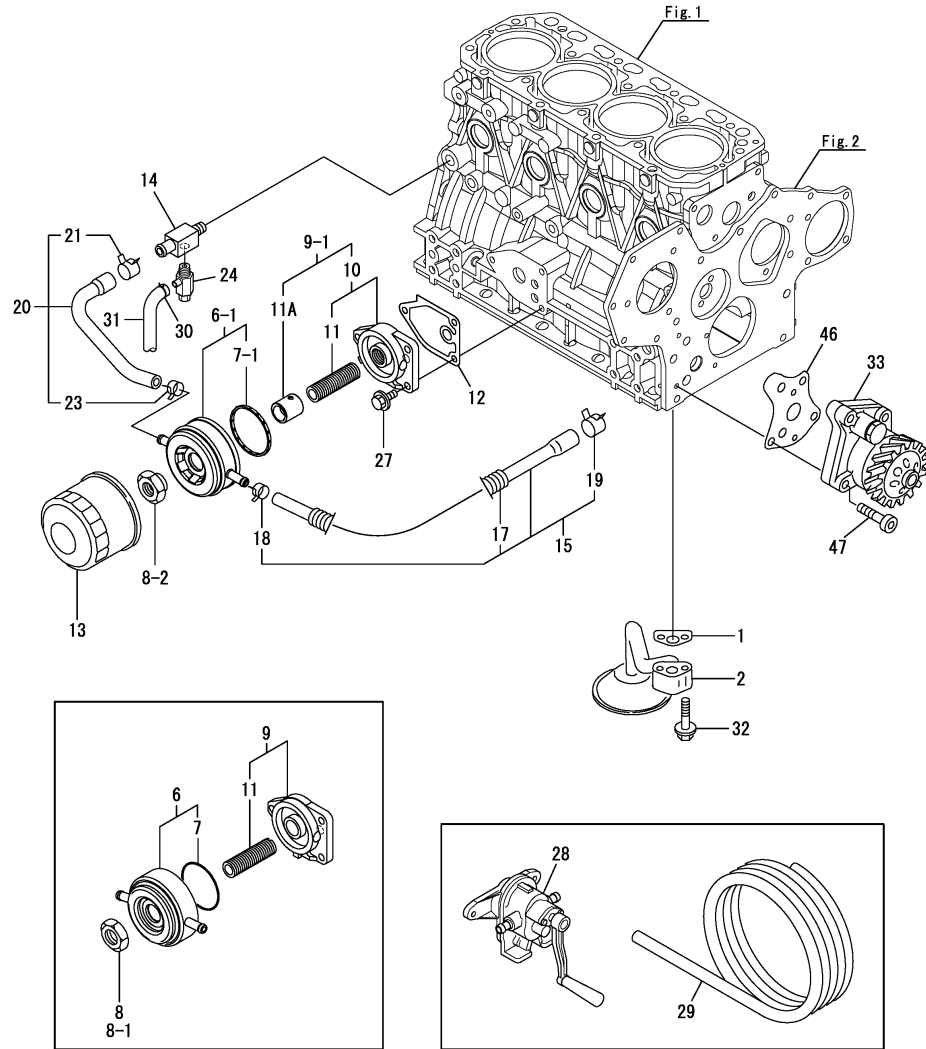

No.	Lev.	Parts No.	Description	Q'ty						I	R
				(A)	(B)	(C)	(D)	(E)	(F)		
1	1	129150-35042	GASKET	1							
2	1	129670-35090	PIPE ASSY, OIL INLET	1							
6	1	129508-33010	COOLER ASSY, OIL	1							
6-1	1	129508-33031 (A=E16928)	COOLER ASSY, OIL	1						F	2
7	2	129508-33050	O-RING	1							
7-1	2	129508-33060 (A=E16928)	PACKING, OIL COOLER	1							S
8	1	129417-33110	NUT	1							
8-1	1	129417-33111 (A=E12474)	NUT, OIL COOLER	1							R
8-2	1	124085-35350 (A=E16928)	NUT, M20	1							F 2
9	1	129006-35100	BRACKET ASSY, FILTER	1							
9-1	1	129508-35100 (A=E16928)	BRACKET ASSY, LO FILT	1							F 2
10	2	129006-35100	BRACKET ASSY, FILTER	1							
11	3	129417-35150	BOLT, STUD M20X67	1							
11A	2	129508-35150 (A=E16928)	COLLAR, OIL-COOLER	1							W
12	1	129150-35111	GASKET	1							
13	1	129150-35170	FILTER, LO	1							1
14	1	129006-44480	JOINT	1							
15	1	129657-49020	PIPE ASSY, WATER	1							
17	2	129657-49180	TUBE, CORRUGATED	1							
18	2	23080-015000	CLAMP, 15	1							
19	2	171008-03990	CLAMP, HOSE 18.5	1							
20	1	129508-49030	HOSE ASSY, WATER	1							
21	2	171008-03990	CLAMP, HOSE 18.5	1							
23	2	23080-015000	CLAMP, 15	1							
24	1	119620-49290	COCK ASSY, 1/4	1							
27	1	26106-080202	BOLT, M8X 20 PLATED	3							
28	1	124413-39100	PUMP ASSY, WASTE	1							
29	1	129670-39990	HOSE, OIL DRAIN 3M	1							
30	1	124460-77680	RETAINER	1							
31	1	23061-070300	PIPE, 7X 300	1							
32	1	26106-080352	BOLT, M8X 35 PLATED	2							
33	1	129407-32000	PUMP ASSY, OIL	1							
46	1	129150-32020	GASKET, PUMP	1							
47	1	26450-060252	BOLT, M6X 25	4							

## Remarks

(1) Spare parts.

(2) No. 6-1, 8-2 &amp; 9-1 interchangeable by set.

 N:Old  $\xrightarrow{\text{Yes}}$  New, Q:Old  $\xrightarrow{\text{No}}$  New, R:Old  $\xrightarrow{\text{Yes}}$  New, S:Old  $\xrightarrow{\text{No}}$  New, W:Add, Z:Discontinued, F:Interchangeable by set, K:Q'ty Change

Copyright (C) YANMAR GLOBAL CS CO., LTD. All Rights Reserved.

(A)=4JH5E  
(B)=  
(C)=

(D)=  
(E)=  
(F)=

No.	Lev.	Parts No.	Description	Q'ty						I	R
				(A)	(B)	(C)	(D)	(E)	(F)		
1	1	124160-39140	BOLT, PIPE JOINT M10	1							
2	1	119802-39450	PIPE ASSY, OIL	1							
3	1	129005-59830	BOLT ASSY, JOINT M8	1							
4	2	22190-080002	WASHER, SEAL 6	1							
5	2	23857-030000	BOLT, JOINT 3	1							
6	1	22190-080002	WASHER, SEAL 6	1							
7	1	22190-100002	WASHER, SEAL 10	2							
8	1	26366-060002	NUT, M6	1							

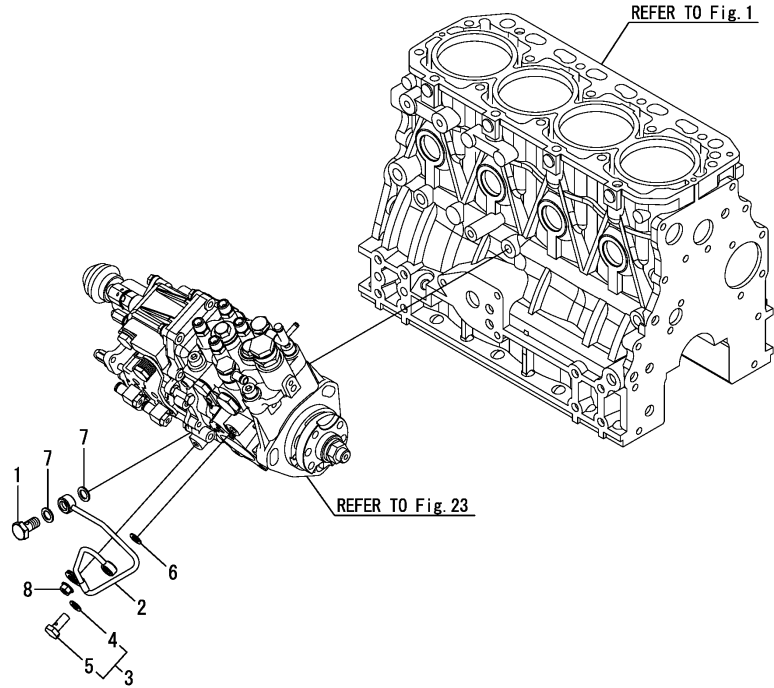

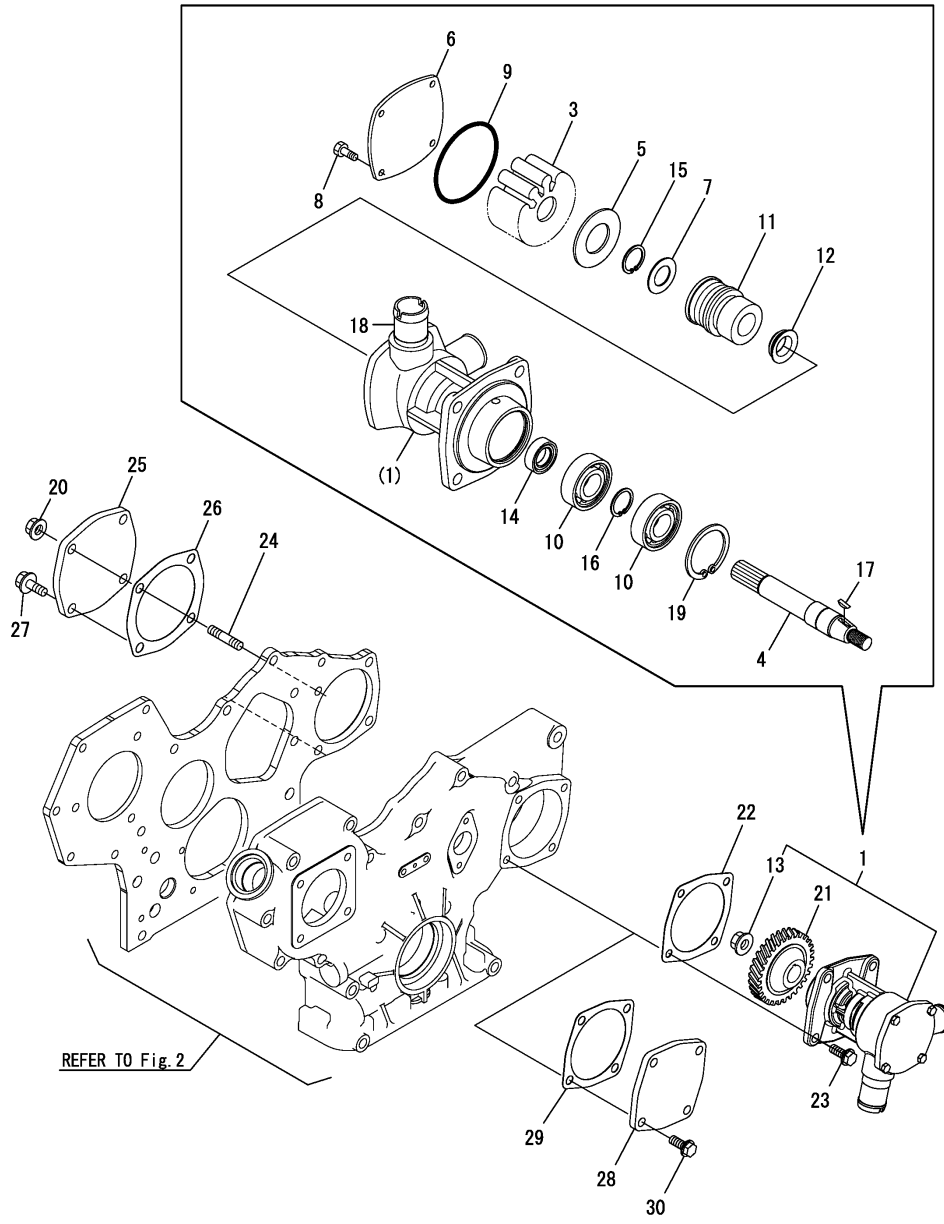

(A)=4JH5E  
(B)=  
(C)=

(D)=  
(E)=  
(F)=

No.	Lev.	Parts No.	Description	Q'ty						I	R
				(A)	(B)	(C)	(D)	(E)	(F)		
1	1	129271-42501	PUMP ASSY, WATER	1							
3	2	129670-42531	IMPELLER	1							
4	2	X0146531	SHAFT	1							
5	2	129670-42540	PLATE	1							
6	2	129670-42520	COVER	1							
7	2	129670-42550	WASHER	1							
8	2	129271-42510	SCREW	4							
9	2	119773-42570	O-RING	1							
10	2	X03431483	BEARING	2							
11	2	129670-42560	SEAL, MECHANICAL	1							
12	2	X02230015	RING	1							
13	2	X00190001	NUT, LOCK	1							
14	2	X02233001	SEAL, LIP	1							
15	2	129670-42570	CIRCLIP	1							
16	2	X00370017	CIRCLIP	1							
17	2	129670-42580	KEY	1							
18	2	123325-49421	JOINT, PIPE	1							
19	2	X00371040	CIRCLIP	1							
20	1	26306-080002	NUT, M8	1							
21	1	129271-42700	GEAR, PUMP	1							
22	1	129150-01881	GASKET	1							
23	1	26106-080202	BOLT, M8X 20 PLATED	4							
24	1	121450-01560	STUD, M8X22	1							
25	1	124240-01871	COVER	1							
26	1	129150-01881	GASKET	1							
26-1	1	129C26-01890	GASKET, HO-P	1							R
(A=*2012.06.)											
27	1	26106-080252	BOLT, M8X 25 PLATED	3							
28	1	124240-01871	COVER	1							
29	1	129150-01881	GASKET	1							
29-1	1	129C26-01890	GASKET, HO-P	1							R
(A=*2012.06.)											
30	1	26106-080162	BOLT, M8X 16 PLATED	4							

(A)=4JH5E

(B)=

(C)=

(D)=

(E)=

(F)=

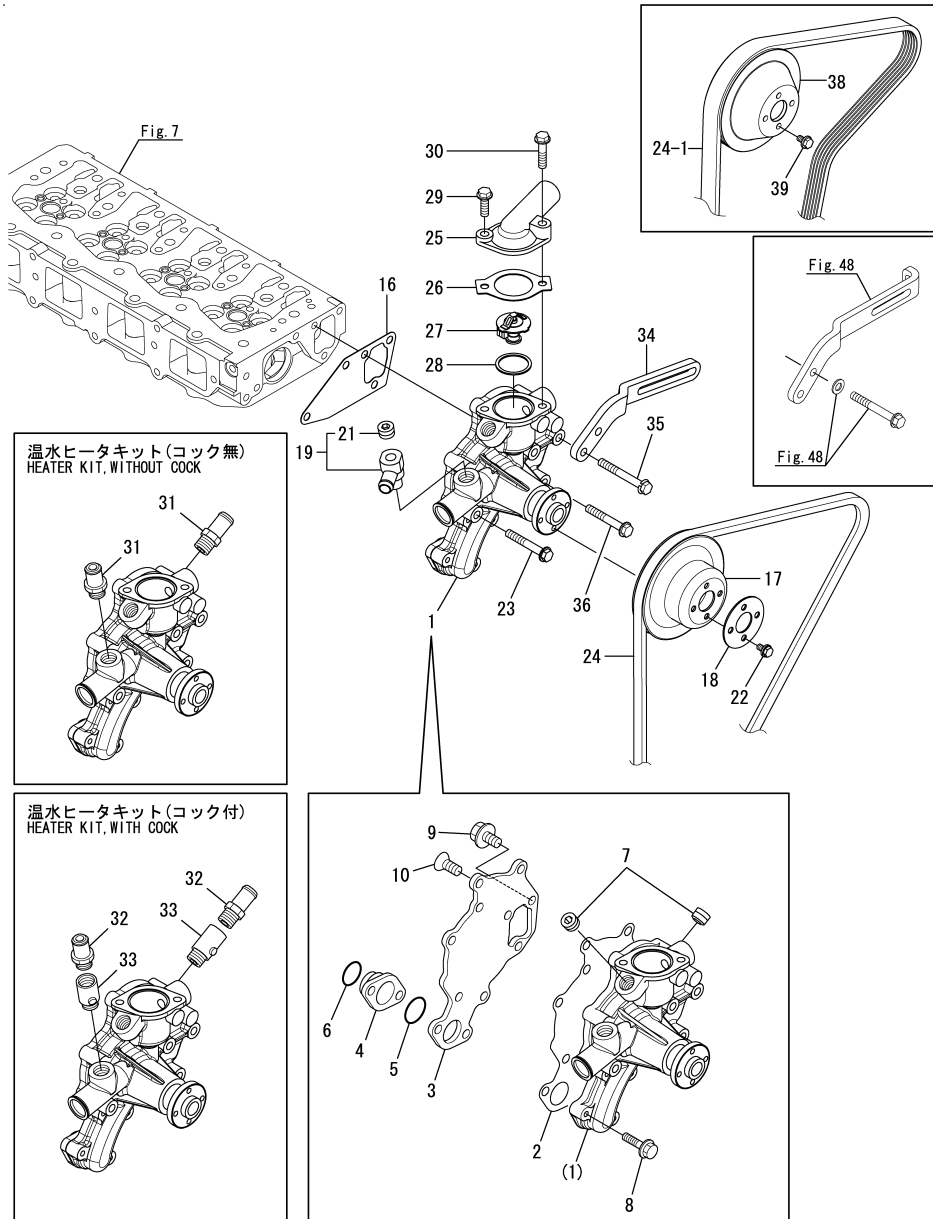

No.	Lev.	Parts No.	Description	Q'ty						I	R
				(A)	(B)	(C)	(D)	(E)	(F)		
1	1	129271-42001	PUMP ASSY, WATER	1							
2	2	129150-42059	GASKET	1							
3	2	129263-42120	PLATE	1							
4	2	129150-42301	FLANGE	1							
5	2	24358-240310	O-RING, 524031	1							
6	2	129054-42320	O-RING	1							
7	2	129916-49740	PLUG, R03	2							
8	2	26106-060202	BOLT, M6X 20 PLATED	2							
9	2	26116-060162	BOLT, M6X 16 PLATED	3							
10	2	26577-060142	SCREW M 6X 14	3							
16	1	129486-42050	GASKET, WATER PUMP	1							
17	1	129550-42350	V-PULLEY, D=120	1							Z 1
(A=E14236)											
18	1	129156-44760	WASHER	1							Z 1
(A=E14236)											
19	1	129270-49400	JOINT ASSY, PUMP	1							
21	2	23875-030000	PLUG, R03	1							
22	1	26106-060102	BOLT, M6X 10 PLATED	4							Z 1
(A=E14236)											
23	1	26106-080552	BOLT, M8X 55 PLATED	2							
24	1	25152-004300	V-BELT, A43	1							1
24-1	1	129271-77680	BELT, ALTERNATOR	1							S 2
(A=E14236)											
25	1	129470-49540	COVER, THERMOSTAT	1							
26	1	129795-49551	GASKET	1							
27	1	129470-49801	THERMOSTAT, 76.5	1							
28	1	129470-49810	GASKET, THERMOSTAT	1							
29	1	26106-080252	BOLT, M8X 25 PLATED	1							
30	1	26106-080352	BOLT, M8X 35 PLATED	1							
31	1	128990-49320	JOINT, 3/8	2							
32	1	128990-49320	JOINT, 3/8	2							
33	1	129670-49390	COCK ASSY, R1/4XRP3/8	2							
34	1	129495-77330	ADJUSTER, BELT	1							Z 1
(A=E14236)											
35	1	26013-080652	BOLT, M8X 65	1							Z 1
(A=E14236)											
36	1	26106-080552	BOLT, M8X 55 PLATED	1							
38	1	129271-42350	PULLEY, CW PUMP 6PK	1							W 2
(A=E14236)											
39	1	26106-060122	BOLT, M6X 12 PLATED	4							W 2
(A=E14236)											

**Remarks**

(1)HITACHI generator spec.

(2)Valeo generator spec.

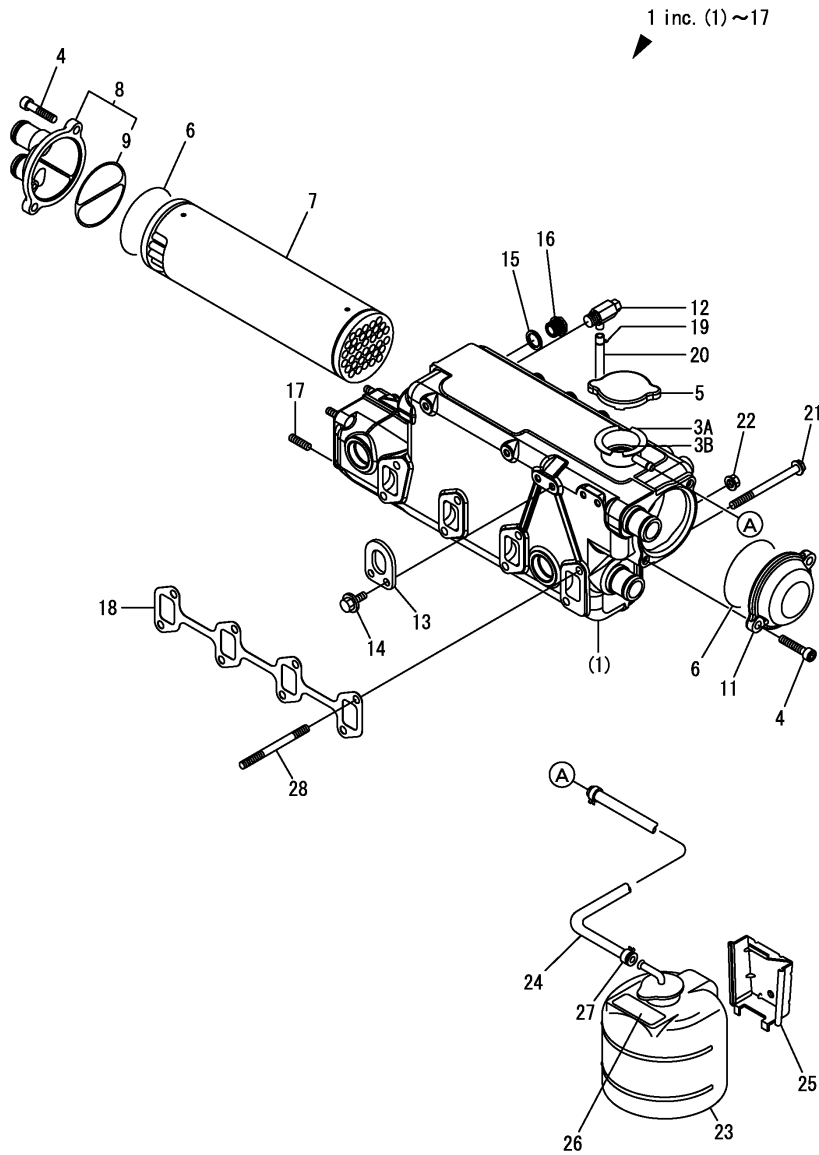

(A)=4JH5E  
(B)=  
(C)=

(D)=  
(E)=  
(F)=

No.	Lev.	Parts No.	Description	Q'ty						I	R
				(A)	(B)	(C)	(D)	(E)	(F)		
1	1	129670-44910	COOLER ASSY, WATER	1							
1-1	1	129670-44911	COOLER ASSY, WATER	1							N
(A=*2012.12.)											
3A	2	129673-44110	NECK, FILLER	1							
3B	2	129673-44150	TUBE, D28.5X1.5 LG6	1							
4	2	129673-44090	BOLT, M8X40	4							
5	2	129673-44131	CAP, FILLER	1							
6	2	129670-44150	O-RING, 74.5X3	2							
7	2	129670-44460	CORE ASSY, COOLER	1							
8	2	129670-44430	COVER CMP,COOLER A	1							
9	3	120322-33050	PACKING, RUBBER	1							
11	2	129670-44450	COVER, COOLER B	1							
12	2	119620-49290	COCK ASSY, 1/4	1							
13	2	129670-07230	LIFTER	1							
14	2	26450-080162	BOLT, M8X 16	2							
15	2	23414-170000	GASKET, 17X1.0	1							
16	2	23894-030002	PLUG, G3/8	1							
17	2	129670-13600	STUD, M8X20	4							
18	1	129550-13110	GASKET, MANIFOLD	1							
19	1	124460-77680	RETAINER, FUEL PIPE	1							
20	1	23061-070300	PIPE, 7X 300	1							
21	1	26106-081002	BOLT, M8X100 PLATED	6							
22	1	26306-080002	NUT, M8	2							
23	1	128397-44500	TANK ASSY, SUB	1							
24	1	129270-44501	PIPE, OVERFLOW	1							
25	1	128397-44510	BRACKET, SUB TANK	1							
26	1	129670-44570	LABEL, SUB TANK	1							
27	1	23010-013000	CLAMP 13	2							
28	1	129693-44300	BOLT, COOLER	2							

(A)=4JH5E  
(B)=  
(C)=

(D)=  
(E)=  
(F)=

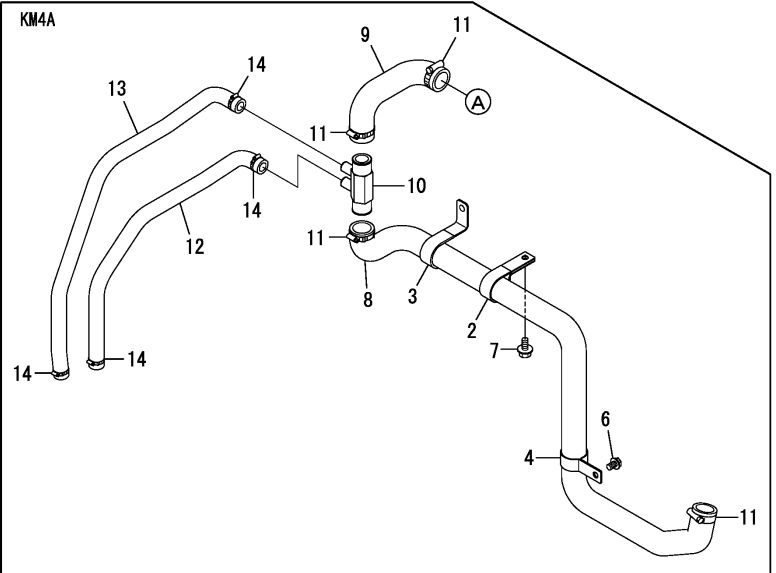
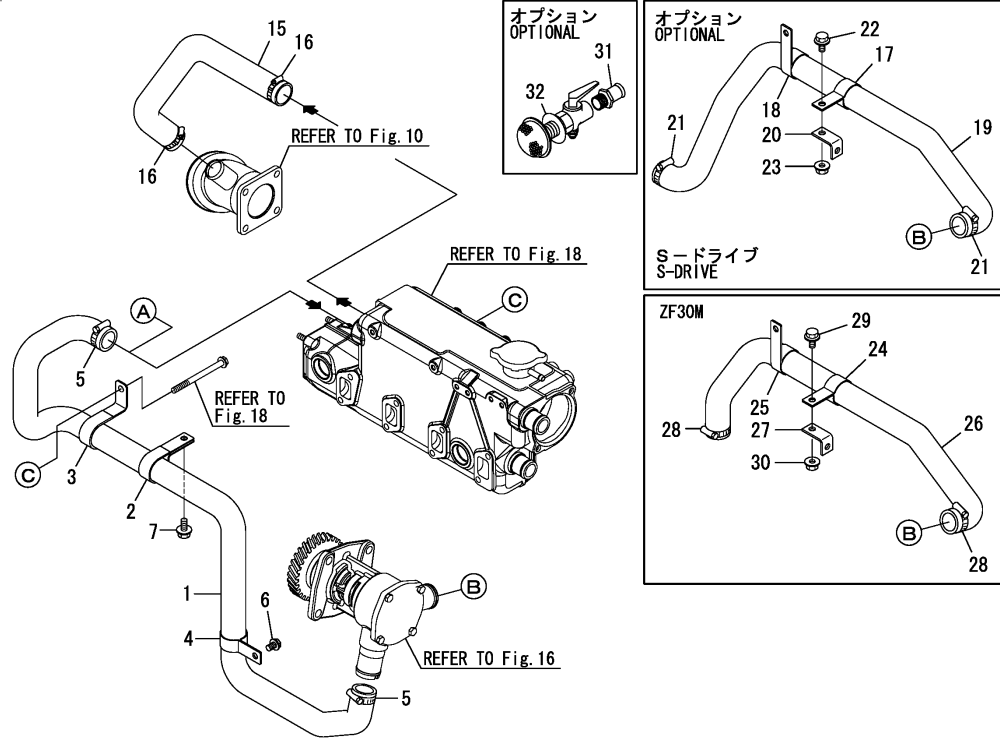

No.	Lev.	Parts No.	Description	Q'ty						I	R
				(A)	(B)	(C)	(D)	(E)	(F)		
1	1	129670-49020	PIPE, WATER	1							
2	1	129671-49120	RETAINER	1							
3	1	129670-49360	RETAINER, PIPE	1							
4	1	129271-49110	RETAINER, PIPE	1							
5	1	129670-49500	CLIP, HOSE 38	2							
6	1	26106-080122	BOLT, M8X 12 PLATED	1							
7	1	26106-080162	BOLT, M8X 16 PLATED	1							
8	1	129670-49090	PIPE, WATER	1							
9	1	129670-49220	PIPE, WATER	1							
10	1	129670-49410	JOINT	1							
11	1	129670-49500	CLIP, HOSE 38	4							
12	1	129670-49230	PIPE, WATER	1							
13	1	129670-49240	PIPE, WATER	1							
14	1	23000-022000	CLAMP, 22	4							
15	1	129670-49150	PIPE, WATER	1							
16	1	129670-49500	CLIP, HOSE 38	2							
17	1	129271-49110	RETAINER, PIPE	1							
18	1	129671-49110	RETAINER	1							
19	1	129670-49260	PIPE,CSW S-DRIVE	1							
20	1	129670-49270	BRACKET	1							
21	1	129670-49500	CLIP, HOSE 38	2							
22	1	26106-080122	BOLT, M8X 12 PLATED	1							
23	1	26306-080002	NUT, M8	1							
24	1	129271-49110	RETAINER, PIPE	1							
25	1	129671-49110	RETAINER	1							
26	1	129670-49250	PIPE, WATER	1							
27	1	129670-49270	BRACKET	1							
28	1	129670-49500	CLIP, HOSE 38	2							
29	1	26106-080122	BOLT, M8X 12 PLATED	1							
30	1	26306-080002	NUT, M8	1							
31	1	43530-500570	JOINT, PIPE	1							
32	1	43662-025031	COCK, KINGSTON	1							



(A)=4JH5E  
(B)=  
(C)=

(D)=  
(E)=  
(F)=

No.	Lev.	Parts No.	Description	Q'ty						I	R
				(A)	(B)	(C)	(D)	(E)	(F)		
1	1	129671-49210	PIPE, WATER	1							
2	1	129671-49220	PIPE, WATER	1							
3	1	129670-49500	CLIP, HOSE 38	4							
4	1	129271-49110 (A=*2009.06)	RETAINER, PIPE	1							W

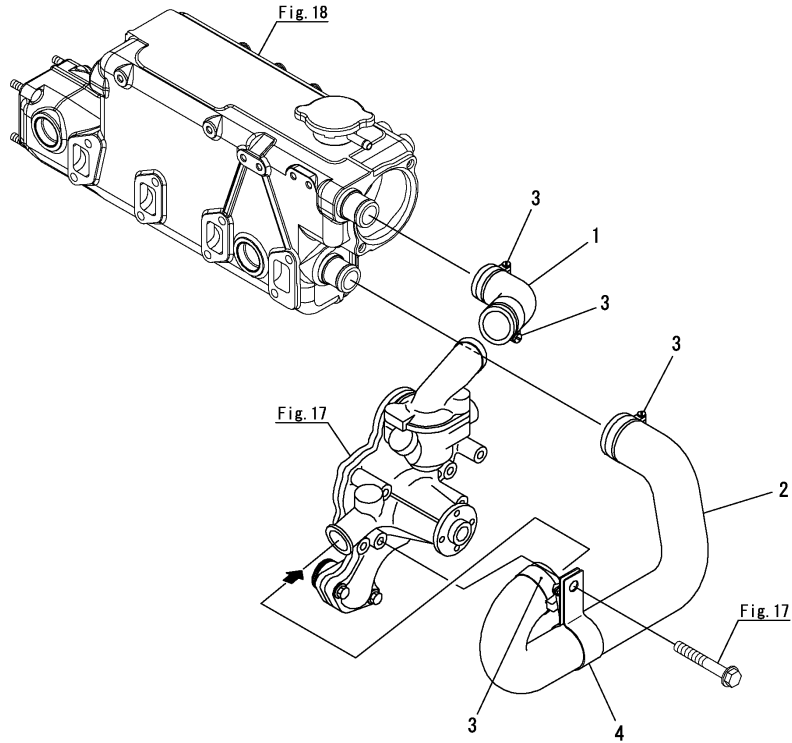



(A)=4JH5E  
(B)=  
(C)=

(D)=  
(E)=  
(F)=

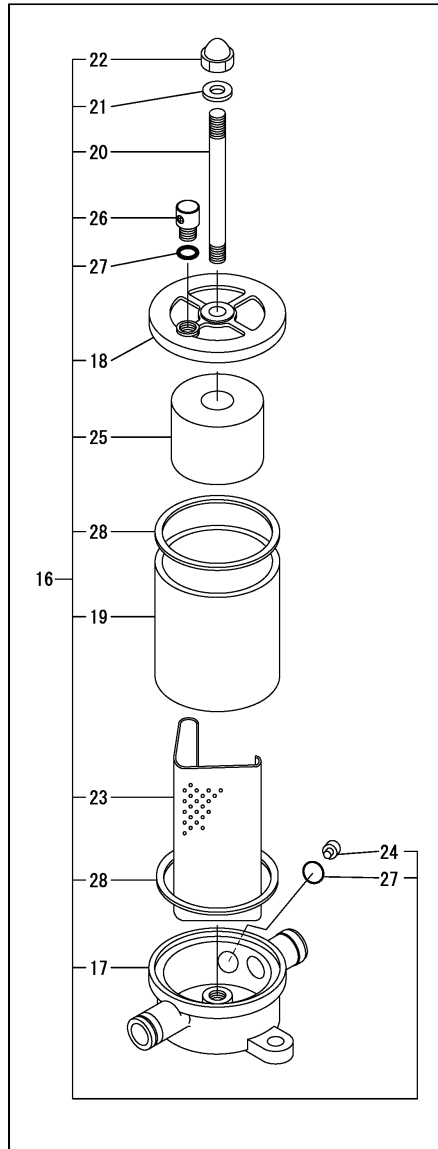
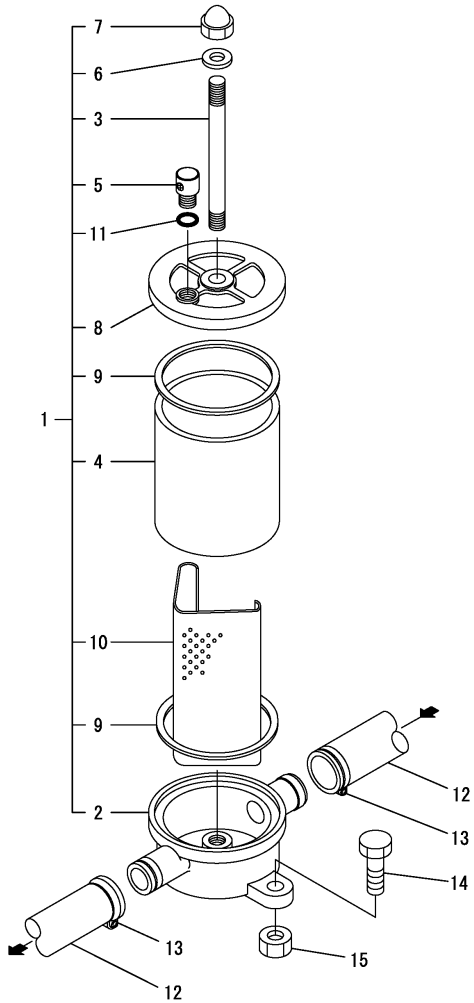

No.	Lev.	Parts No.	Description	Q'ty						I	R
				(A)	(B)	(C)	(D)	(E)	(F)		
1	1	129795-48800 (A=*2001.09)	STRAINER	1							Z
2	2	XTST25S001	BODY	1							
3	2	XTST25S002	BOLT, M8X125	1							
4	2	XTST25S003	PIPE, OUTER	1							
5	2	XTST25S004	PLUG, AIR VENT M8	1							
6	2	XTST25S005	PACKING	1							
7	2	26664-080002	NUT, CAP M8	1							
8	2	XTST25S007	COVER, UPPER	1							
9	2	XTST25S008	PACKING	2							
10	2	XTST25S009	SCREEN	1							
11	2	24311-000060	O-RING, 1AP6.0	1							
12	1	23072-101000	HOSE, 10X1000	1							
13	1	129670-49500	CLIP, HOSE 38	2							
14	1	26116-080302	BOLT, M8X 30 PLATED	2							
15	1	26703-080002	NUT, M8	2							
16	1	129795-48801 (A=*2001.09)	STRAINER ASSY,SEA WA	1							W 1
17	2	129795-48810	BODY	1							
18	2	129795-48820	CAP,UPPER	1							
19	2	129795-48830	CYLINDER,OUTER	1							
20	2	129795-48840	BOLT	1							
21	2	129795-48850	O-RING	1							
22	2	129795-48860	NUT, CAP	1							
23	2	129795-48870	STRAINER	1							
24	2	129795-48880	PLUG, DRAIN	1							
25	2	129795-48890	ZINC, ANTI-CORROSIVE	1							
26	2	129795-48900	PLUG, AIR VENT	1							
27	2	24311-000080	O-RING, 1AP8.0	2							
28	2	24321-000750	O-RING, 1AG75.0	2							

Remarks

(1)No.16 is interchangeable with No.1.

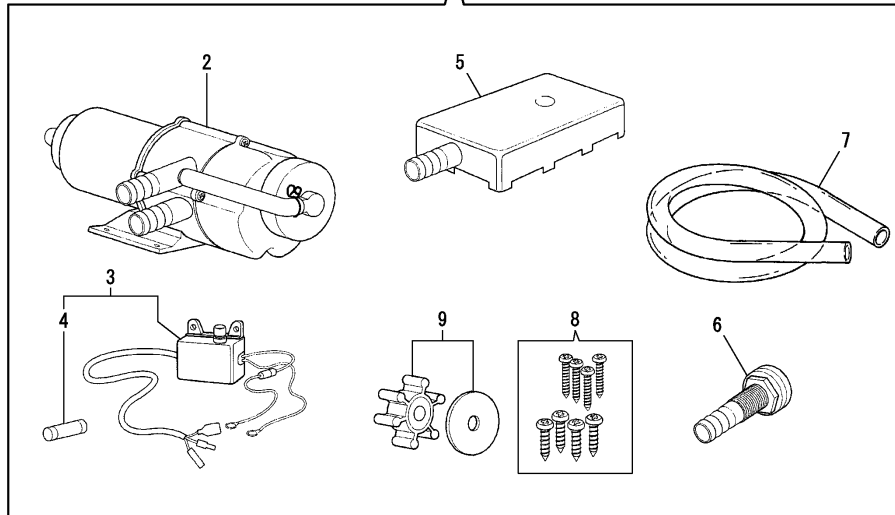
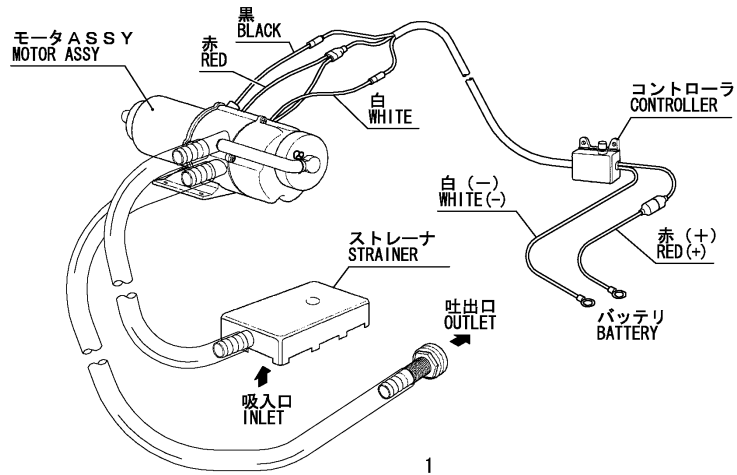

(A)=4JH5E  
(B)=  
(C)=

(D)=  
(E)=  
(F)=

No.	Lev.	Parts No.	Description	Q'ty						I	R
				(A)	(B)	(C)	(D)	(E)	(F)		
1	1	977780-01211	PUMP ASSY, BILGE	1							
2	2	X0318101004	MOTOR ASSY, BILGE	1							
3	2	X158606410X	SWITH	1							
4	3	X8636015001	FUSE	1							
5	2	X179100022X	STRAINER	1							
6	2	X179100100X	PIPE ASSY	1							
7	2	X0044021509	HOSE A	1							
8	2	X199906101X	SCREW SET	1							
9	2	977780-03000	INPELLER	1							

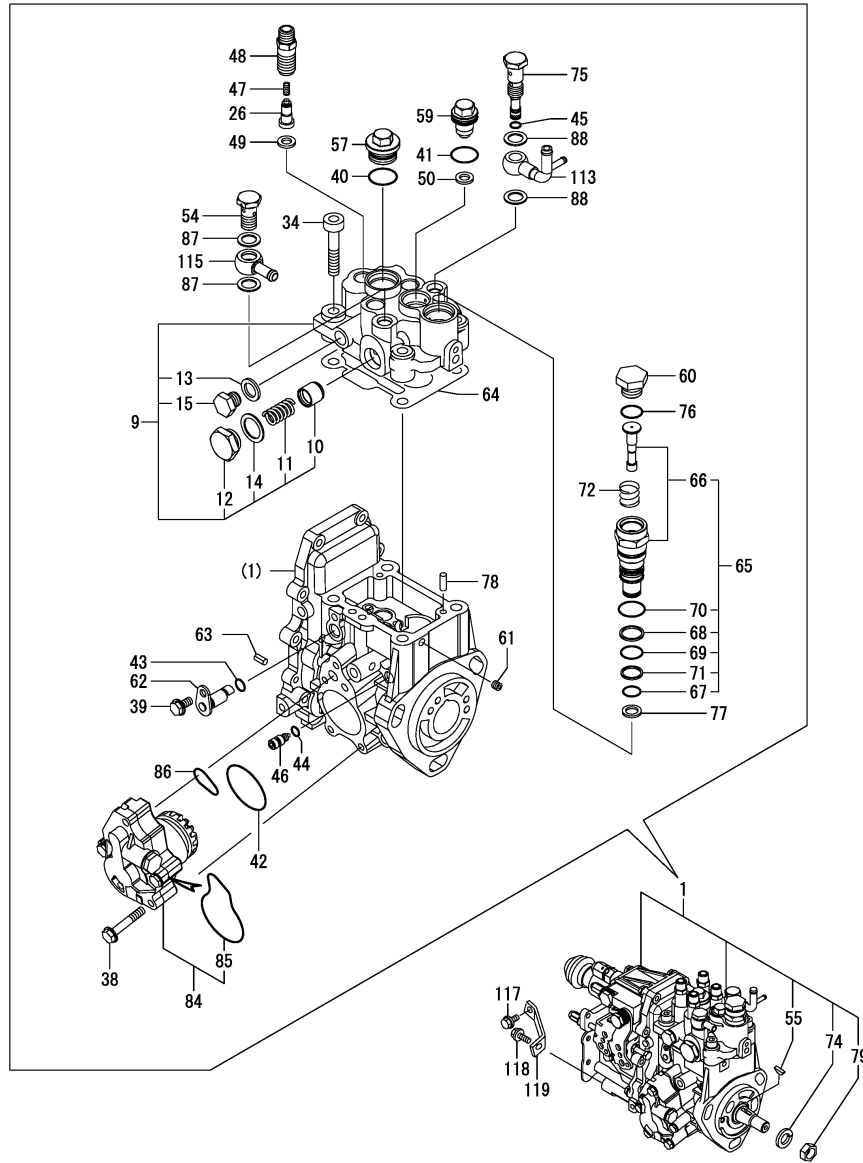

(A)=4JH5E  
(B)=  
(C)=

(D)=  
(E)=  
(F)=

No.	Lev.	Parts No.	Description	Q'ty						I	R
				(A)	(B)	(C)	(D)	(E)	(F)		
1	1	729670-51330	PUMP ASSY, INJECTION	1							1
9	3	158553-51741	HEAD ASSY	1							
10	4	158601-51770	PISTON	1							
11	4	158552-51781	SPRING	1							
12	4	158601-51790	PLUG	1							
13	4	22190-120002	WASHER, SEAL 12	1							
14	4	22190-180002	WASHER, SEAL 18	1							
15	4	23887-120002	PLUG, 12	1							
26	3	129009-51390	VALVE ASSY, DELIVERY	4							
34	3	26450-080452	BOLT, M8X 45	4							
38	3	158553-51770	BOLT	4							
39	3	26106-060102	BOLT, M6X 10 PLATED	1							
40	3	24356-010200	O-RING, 4D1020	1							
41	3	24356-010180	O-RING, 4D1018	1							
42	3	158552-52400	O-RING, 4E S42	1							
43	3	24311-000070	O-RING, 1AP7.0	1							
44	3	158563-51281	O-RING, 4D S6	1							
45	3	158563-51281	O-RING, 4D S6	1							
46	3	158600-51270	STOPPER, TAPPET	1							
47	3	158563-51330	SPRING, DELIVERY	4							
48	3	129928-51340	HOLDER, DELIVERY	4							
49	3	158552-51571	GASKET	4							
50	3	158552-51571	GASKET	1							
54	3	23857-060000	BOLT, JOINT 6	1							
55	3	119802-51090	KEY, 4X16	1							
57	3	158601-51550	PLUG	1							
59	3	119802-51560	PLUG, BARREL	1							
60	3	129670-51600	PLUG	1							
61	3	158557-51570	PLUG	1							
62	3	158552-51580	LIFTER	1							
63	3	22351-050010	PIN, SPRING 5.0X10	2							
64	3	158552-51600	GASKET	1							
65	3	119802-51590	TIMER SET	1							
66	4	119802-51600	TIMER ASSY	1							
67	4	158553-51670	O-RING, 1011	1							
68	4	119802-51680	RING, BACK UP	1							
69	4	119802-51690	O-RING	1							
70	4	24356-010200	O-RING, 4D1020	1							
71	4	24372-000150	RING, BACK UP T2P15	1							
72	3	158553-51630	SPRING, TIMER	1							
74	3	22217-140000	WASHER, SPRING 14	1							
75	3	158601-51650	JOINT, OVER FLOW	1							
76	3	158553-51660	O-RING, P14	1							
77	3	158553-51680	GASKET	1							
78	3	22312-050140	PIN, PARALLEL M5X14	2							
79	3	26776-140002	NUT, LOCK M14	1							
84	3	158552-52100	PUMP ASSY, FUEL FEED	1							
85	4	158552-52500	O-RING	1							
86	3	158552-52310	O-RING	1							
87	3	22190-120002	WASHER, SEAL 12	2							
88	3	22190-120002	WASHER, SEAL 12	2							

Remarks  
(1)GOVERNOR ASSY(FIG.24)IS  
INCORPORATED IN THIS  
FUEL INJECTION PUMP(REF.NO.1)

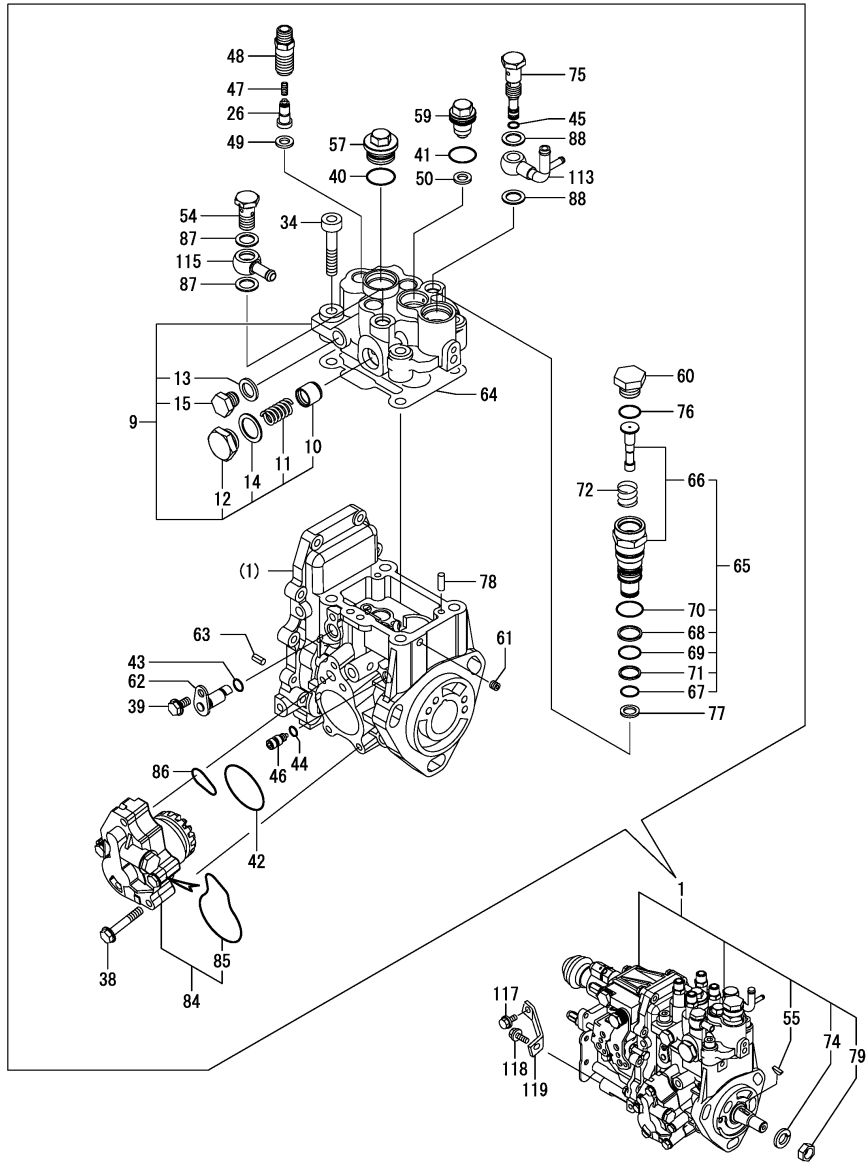

(A)=4JH5E  
(B)=  
(C)=

(D)=  
(E)=  
(F)=

No.	Lev.	Parts No.	Description	Q'ty						I	R
				(A)	(B)	(C)	(D)	(E)	(F)		
113	2	158552-51670	JOINT, OVER FLOW	1							
115	2	129916-59020	JOINT, PIPE 12	1							
117	1	26106-080162	BOLT, M8X 16 PLATED	1							
118	1	26106-080202	BOLT, M8X 20 PLATED	1							
119	1	129601-51250	RETAINER, PUMP	1							

Remarks  
(1)GOVERNOR ASSY(FIG.24)IS  
INCORPORATED IN THIS  
FUEL INJECTION PUMP(REF.NO.1)

(A)=4JH5E  
(B)=  
(C)=

(D)=  
(E)=  
(F)=

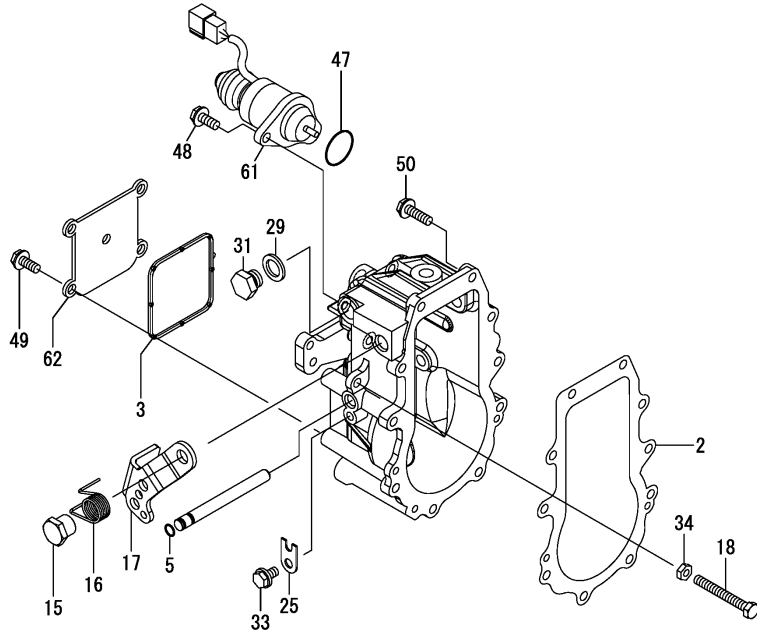

No.	Lev.	Parts No.	Description	Q'ty						I	R
				(A)	(B)	(C)	(D)	(E)	(F)		
2	3	158553-61050	GASKET	1							
3	3	158553-61070	GASKET	1							
5	4	129155-51280	O-RING, S6	1							
15	4	129255-61410	NUT, LOCK	1							
16	4	119807-61420	SPRING, RETURN	1							
17	4	158552-61441	LEVER, REGULATOR	1							
18	4	129155-61460	BOLT, IDLE	1							
25	4	119660-61901	RETAINER, SHAFT	1							
29	4	22190-120002	WASHER, SEAL 12	1							
31	4	23887-120002	PLUG, 12	1							
33	4	26106-060102	BOLT, M6X 10 PLATED	1							
34	4	26756-060002	NUT, LOCK M6	1							
47	3	158552-61900	O-RING	1							
48	3	26106-060142	BOLT, M6X 14 PLATED	2							
49	3	26106-060142	BOLT, M6X 14 PLATED	4							
50	3	26106-060202	BOLT, M6X 20 PLATED	10							
61	2	129271-77950	SOLENOID, STOP	1							
62	2	129642-61060	COVER, GOVERNOR CASE	1							

(A)=4JH5E  
(B)=  
(C)=

(D)=  
(E)=  
(F)=

No.	Lev.	Parts No.	Description	Q'ty						I	R
				(A)	(B)	(C)	(D)	(E)	(F)		
1	1	119225-52102	PUMP ASSY, FUEL FEED	1							
2	1	129670-55010	BRACKET, PUMP	1							
3	1	129670-59110	PIPE, FUEL	1							
4	1	121750-59890	BAND, 140	1							
5	1	121750-59890	BAND, 140	1							
6	1	23000-013000	CLAMP, 13	2							
7	1	26106-060122	BOLT, M6X 12 PLATED	2							
8	1	26106-080702	BOLT, M8X 70 PLATED	1							
9	1	26306-080002	NUT, M8	1							

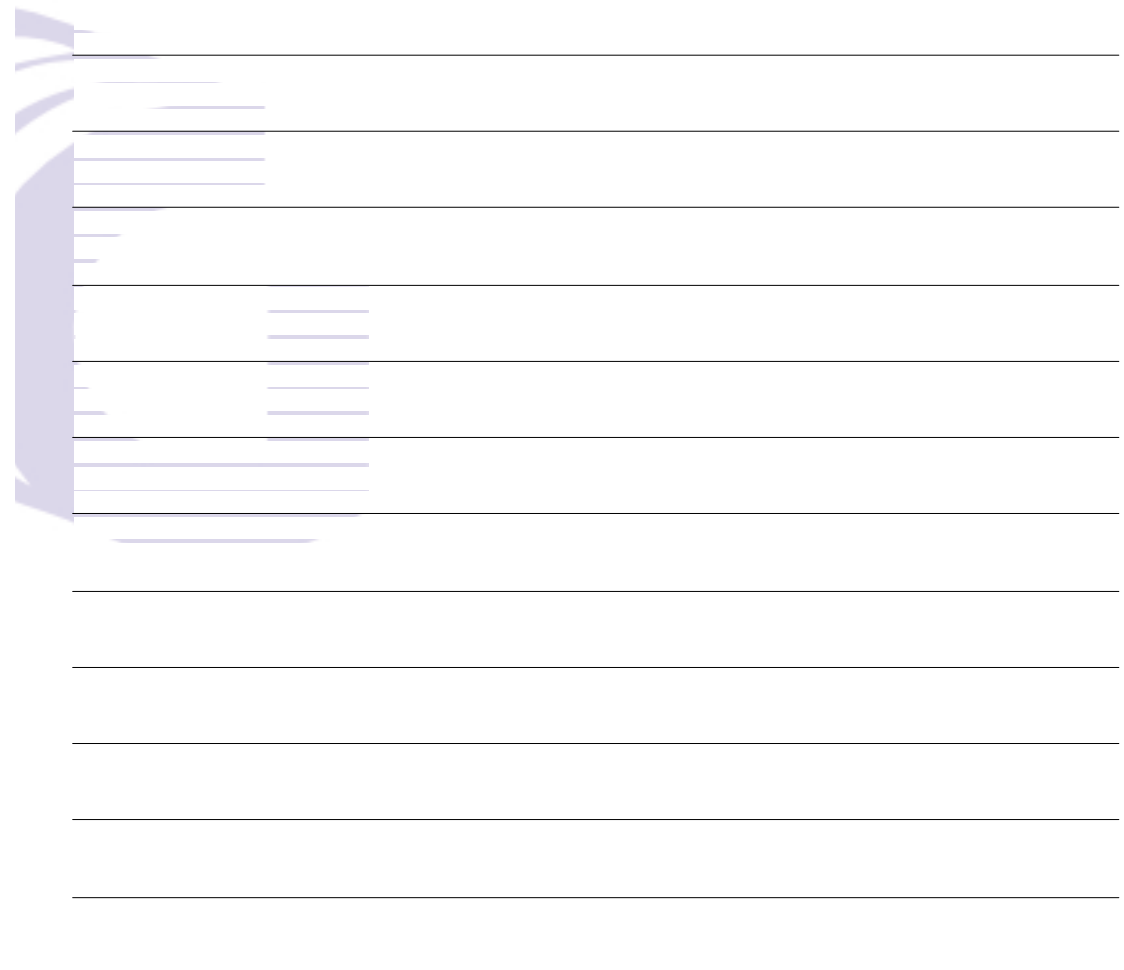
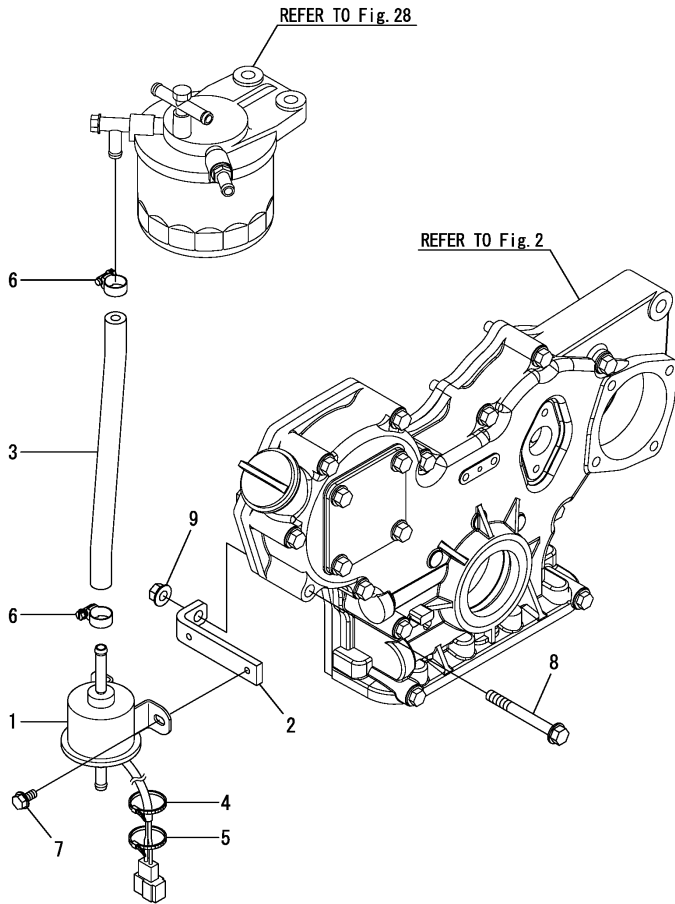

(A)=4JH5E  
(B)=  
(C)=

(D)=  
(E)=  
(F)=

No.	Lev.	Parts No.	Description	Q'ty						I	R
				(A)	(B)	(C)	(D)	(E)	(F)		
1	1	729271-53100	VALVE ASSY,INJECTION	4							
2	2	129008-53000	VALVE ASSY,INJECTION	4							
5	2	114250-53080	NUT, NOZZLE D16.95	4							
10	2	114250-53120	SPRING, NOZZLE	4							
11	2	114250-53130	SEAT, SPRING	4							
12	2	114250-53140	PLATE	4							
13	2	114250-53210	PIN	8							
14	2	119803-53400	SHIM SET	4							

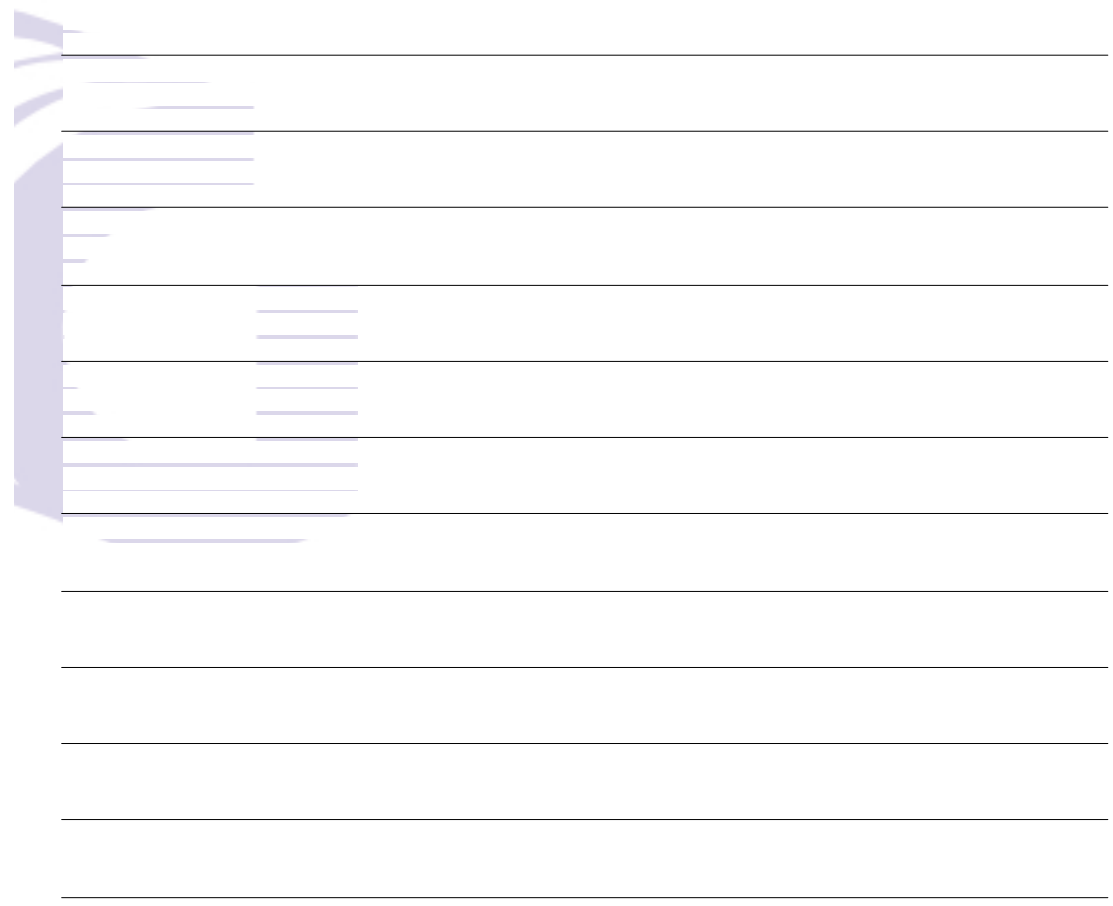
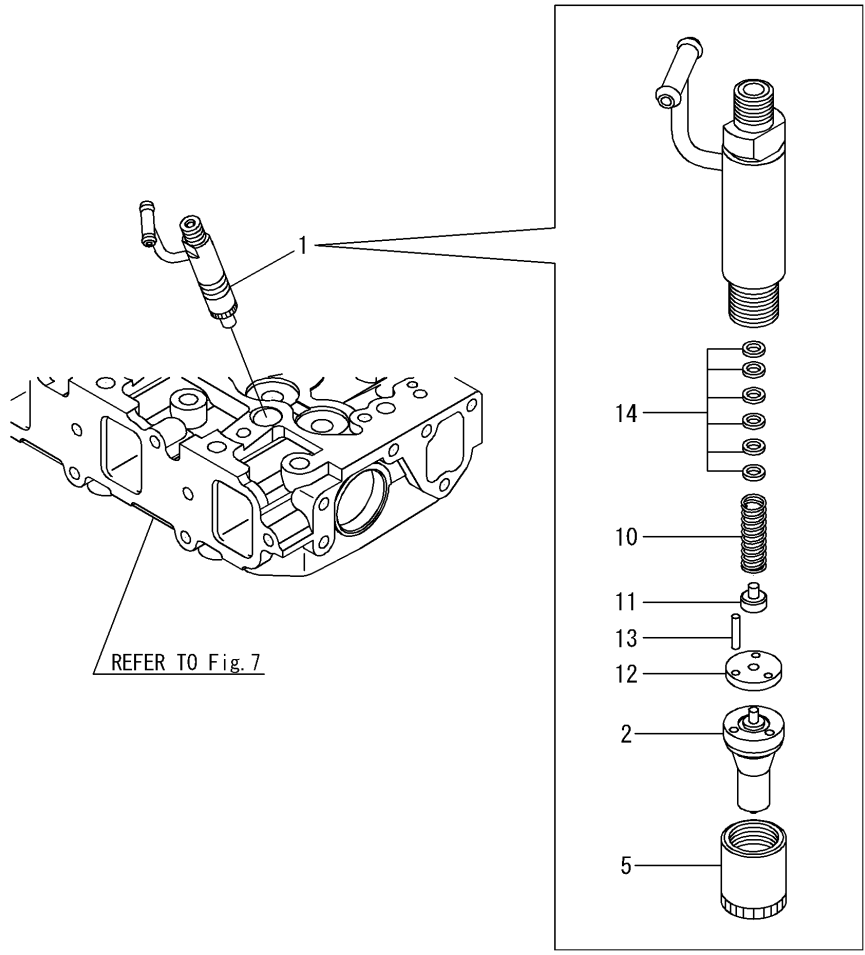

(A)=4JH5E  
(B)=  
(C)=

(D)=  
(E)=  
(F)=

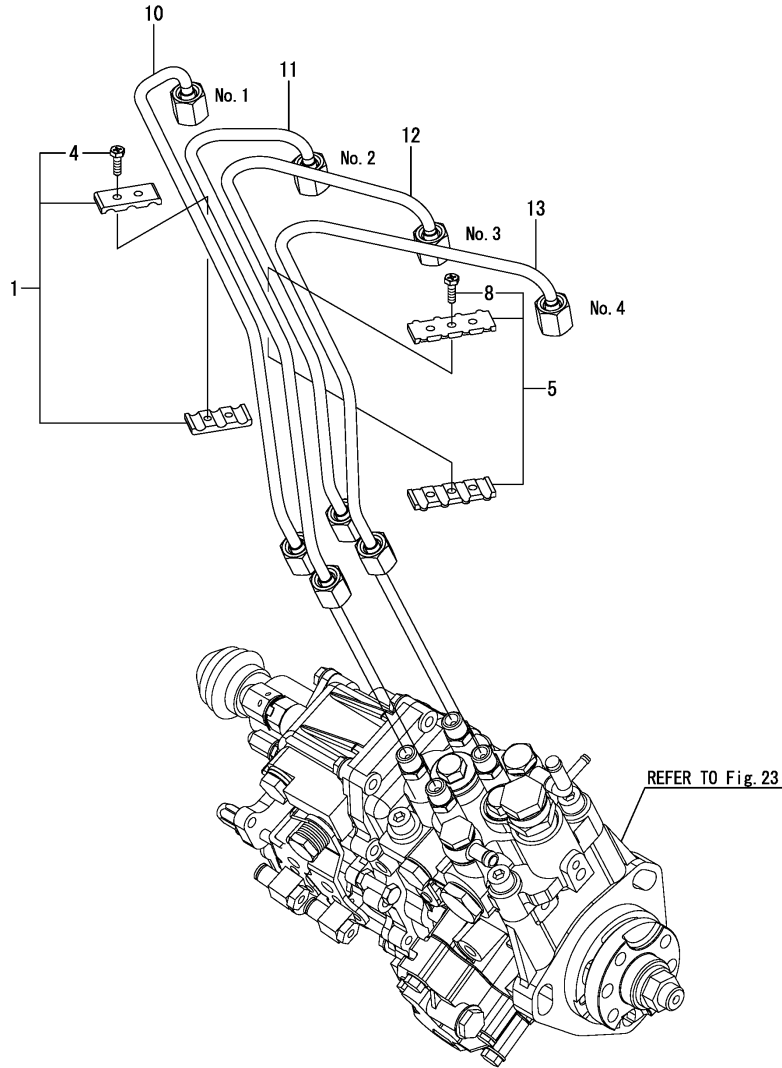

No.	Lev.	Parts No.	Description	Q'ty						I	R
				(A)	(B)	(C)	(D)	(E)	(F)		
1	1	129150-59120	RETAINER, PIPE	1							
4	2	129150-59131	BOLT, M4X14	2							
5	1	129550-59120	RETAINER, PIPE	1							
8	2	129150-59131	BOLT, M4X14	2							
10	1	129670-59710	PIPE ASSY, INJECTION	1							
11	1	129670-59720	PIPE ASSY, INJECTION	1							
12	1	129670-59730	PIPE ASSY, INJECTION	1							
13	1	129670-59740	PIPE ASSY, INJECTION	1							



(A)=4JH5E  
(B)=  
(C)=

(D)=  
(E)=  
(F)=

REFER TO Fig. 9

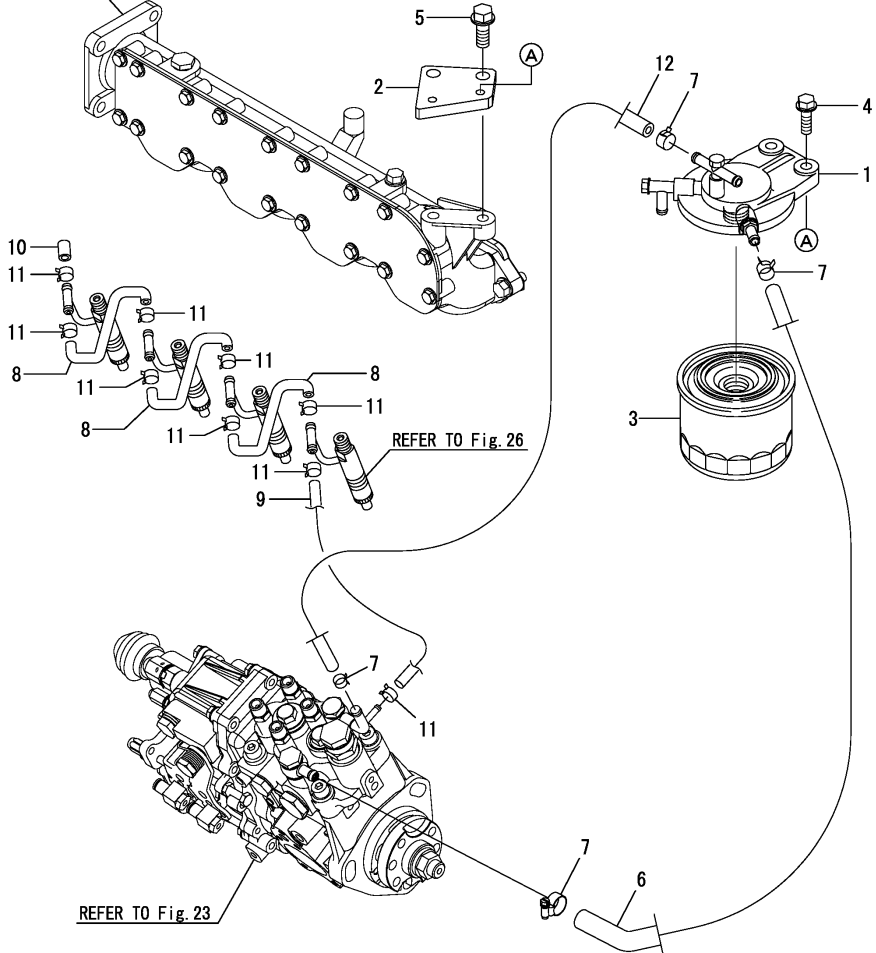

No.	Lev.	Parts No.	Description	Q'ty						I	R
				(A)	(B)	(C)	(D)	(E)	(F)		
1	1	129004-55612	BRACKET, FILTER	1							
2	1	129670-55670	BRACKET, FILTER	1							
3	1	119802-55810	FILTER,FO	1							
4	1	26106-080252	BOLT, M8X 25 PLATED	2							
5	1	26106-100252	BOLT, M10X 25 PLATED	2							
6	1	129670-59150	PIPE, FUEL	1							
7	1	23000-016000	CLAMP, 16	4							
8	1	129270-59550	PIPE, FUEL	3							
9	1	129495-59563	PIPE, FUEL	1							
10	1	129270-59580	CAP	1							
11	1	23000-013000	CLAMP, 13	9							
12	1	129670-59140	PIPE, FUEL OIL	1							

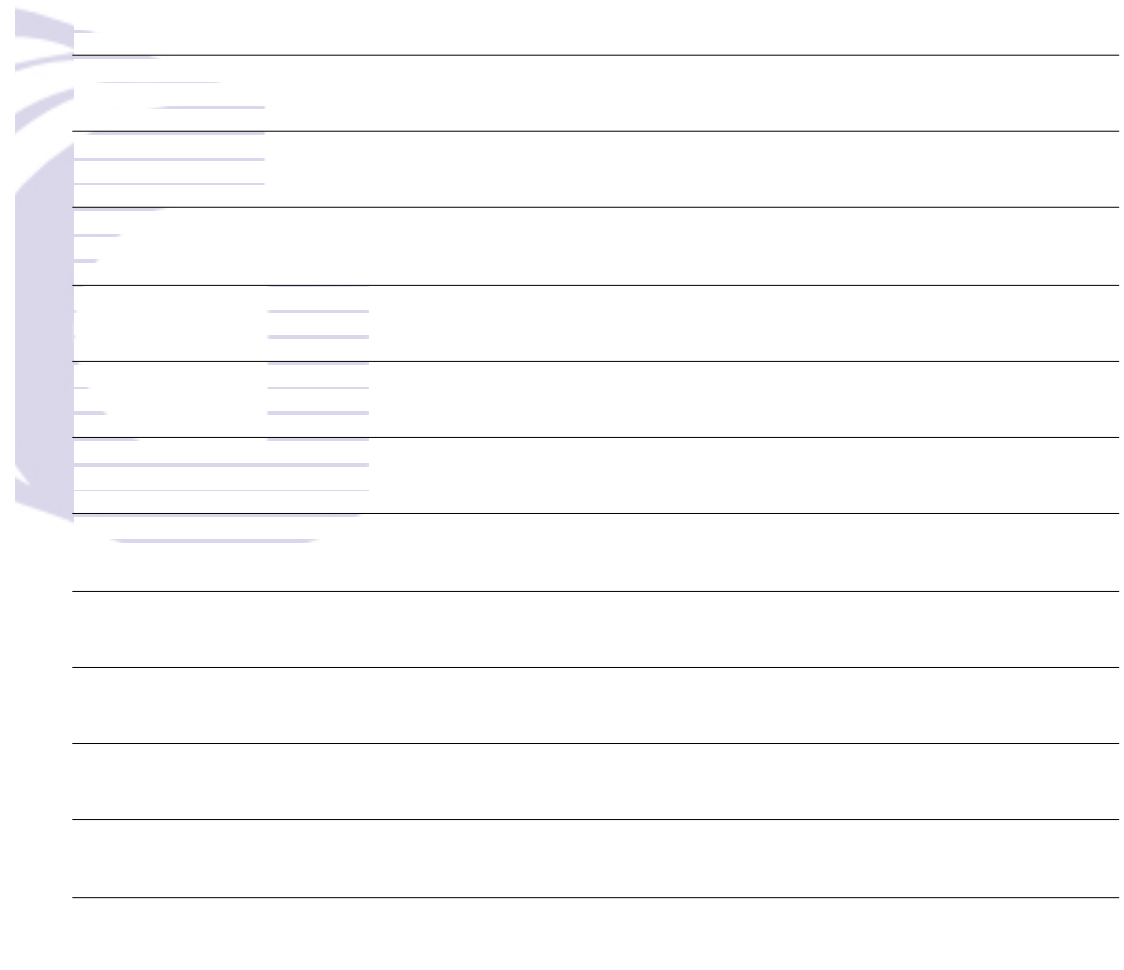

(A)=4JH5E  
(B)=  
(C)=

(D)=  
(E)=  
(F)=

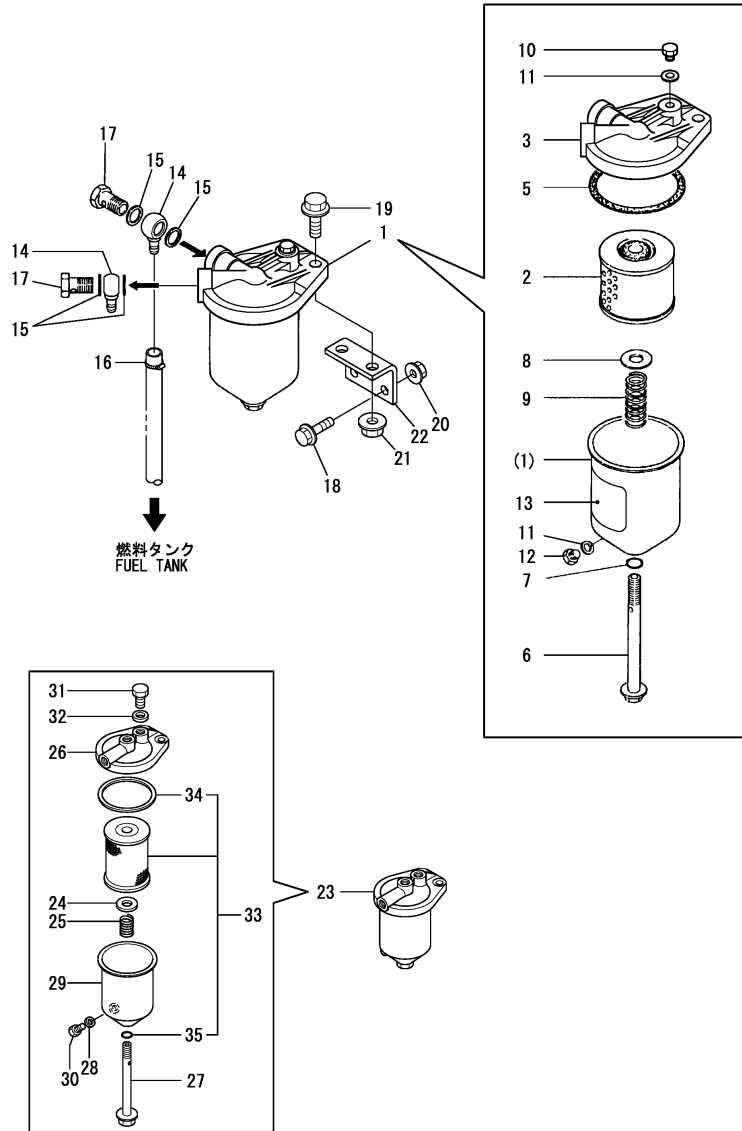

No.	Lev.	Parts No.	Description	Q'ty						I	R	
				(A)	(B)	(C)	(D)	(E)	(F)			
1	1	120324-55751	SEPARATOR ASSY	1							Z	1
		(A=EXXXXX)										
2	2	120324-55760	ELEMENT	1								
3	2	X2740134002	COVER ASSY	1								
5	2	X0582810173	GASKET	1								
6	2	X0311121522	BOLT	1								
7	2	X0580121073	O-RING, 1A P 12.0	1								
8	2	X0300120414	SEAT, SPRING	1								
9	2	X0600160122	SPRING	1								
10	2	X0314080110	PLUG	1								
11	2	X0588080273	WASHER	2								
12	2	X0313080922	BOLT	1								
13	2	X0993071171	LABEL, CAUTION	1								
14	1	121750-59910	JOINT	2								
15	1	22190-140002	WASHER, SEAL 14	4								
16	1	23000-013000	CLAMP, 13	2								
17	1	23857-080000	BOLT, JOINT 8	2								
18	1	26106-080302	BOLT, M8X 30 PLATED	2								
19	1	26106-100302	BOLT, M10X 30 PLATED	2								
20	1	26306-080002	NUT, M8	2								
21	1	26306-100002	NUT, M10	2								
22	1	129670-55810	BRACKET	1								
23	1	129670-55750	SEPARATOR ASSY	1								W
		(A=EXXXXX)										
24	2	123325-35160	WASHER	1								
25	2	123325-35170	SPRING	1								
26	2	129495-55610	BODY, STRAINER	1								
27	2	129495-55620	BOLT	1								
28	2	123672-55760	GASKET	1								
29	2	129065-55760	CASE	1								
30	2	129065-55770	PLUG, DRAIN M8	1								
31	2	129065-55800	PLUG, M14	1								
32	2	123678-55890	GASKET	1								
33	2	41650-502320	ELEMENT ASSY(D72XL90	1								
34	3	123325-35140	GASKET	1								
35	3	24311-000120	O-RING, 1AP12.0	1								

Remarks  
(1)Interchangeability is <N> with  
No.23.

(A)=4JH5E  
(B)=  
(C)=

(D)=  
(E)=  
(F)=

No.	Lev.	Parts No.	Description	Q'ty						I	R
				(A)	(B)	(C)	(D)	(E)	(F)		
1	1	128990-59700	PIPE ASSY, FUEL	1							
2	2	128990-59131	PIPE, FUEL	1							
4	2	138603-59380	CAP NUT	1							
5	2	23010-014000	CLAMP, 14	2							
7	1	83213-003012	TANK ASSY, FUEL OIL	1							
8	2	105430-55041	CAP ASSY	1							

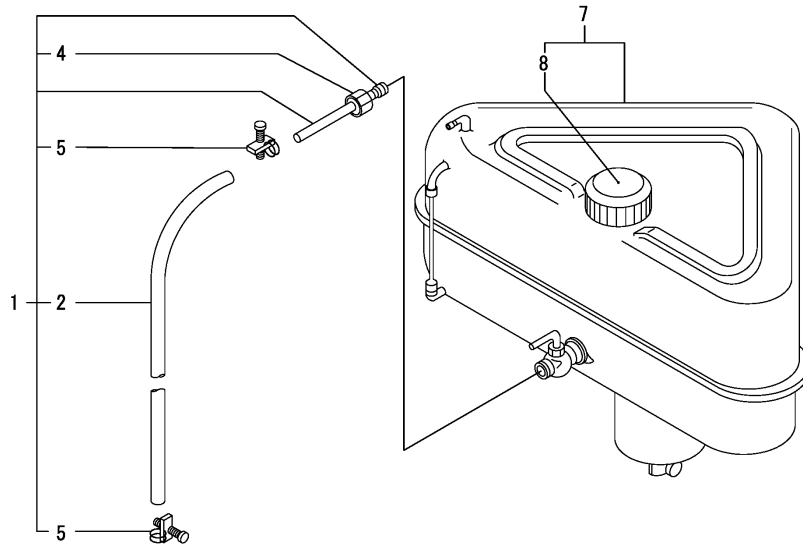

(A)=4JH5E  
(B)=  
(C)=

(D)=  
(E)=  
(F)=

No.	Lev.	Parts No.	Description	Q'ty						I	R
				(A)	(B)	(C)	(D)	(E)	(F)		
1	1	129670-67120	BRACKET, GOVERNOR	1							
2	1	129470-67200	RETAINER ASSY	1							
6	2	22242-000100	RING, 10	1							
7	1	22217-050000	WASHER, SPRING 5	2							
8	1	22217-080000	WASHER, SPRING 8	2							
9	1	22414-250150	PIN, COTTER 2.5X15	1							
10	1	23414-080000	GASKET, 8X1.0	1							
11	1	26106-080252	BOLT, M8X 25 PLATED	1							
12	1	26306-080002	NUT, M8	1							
13	1	26557-050122	SCREW, M5X12	2							
14	1	26716-050002	NUT, M5	2							
15	1	26106-080122	BOLT, M8X 12 PLATED	2							
16	1	129670-67110	BRACKET	1							
17	1	41710-000410	CLAMP	1							
18	1	41710-000380	CABLE L=4000	2							1
19	1	129470-86500	CABLE, L=7000	2							1
20	1	41730-000681	MT-3 REMO-CON	1							1
21	1	128170-86501	REMOCON HEAD (MN)	1							1

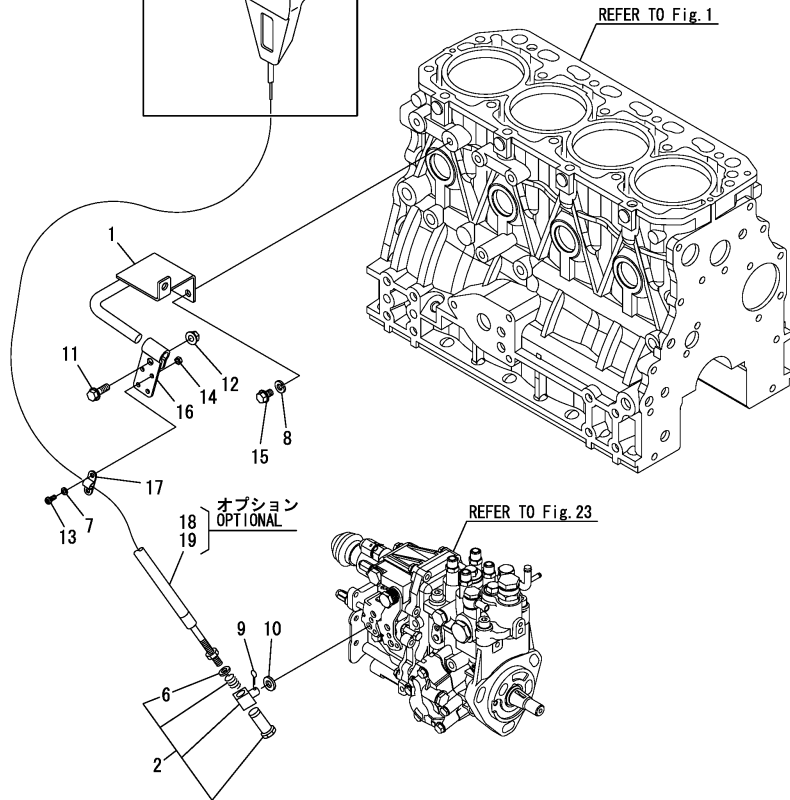
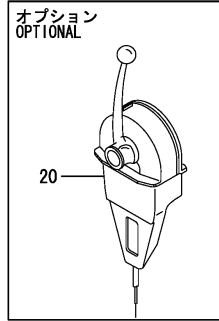
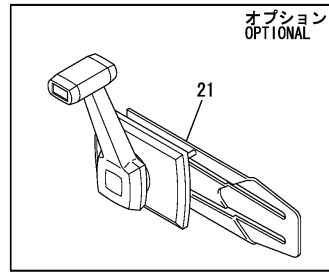

Remarks  
(1)OPTIONAL

(A)=4JH5E  
(B)=  
(C)=

(D)=  
(E)=  
(F)=

No.	Lev.	Parts No.	Description	Q'ty						I	R
				(A)	(B)	(C)	(D)	(E)	(F)		
1	1	129670-77800	CLUTCH ASSY	1							
2	1	129670-77810	CLUTCH ASSY	1							
3	1	129670-77820	CLUTCH ASSY	1							
4	1	129670-77830	CLUTCH ASSY	1							
5	1	129270-81110	CLUTCH ASSY, 2.36	1							
6	1	129270-81120	CLUTCH ASSY, I=2.61	1							
7	1	129670-81200	CLUTCH ASSY, 2.33	1							
8	1	129670-81210	CLUTCH ASSY, I=2.64	1							
9	1	129670-81040	CLUTCH ASSY, 1.47	1							
10	1	129670-81050	CLUTCH ASSY, 2.14	1							
11	1	129670-81060	CLUTCH ASSY, I=2.63	1							
12	1	129670-81100	CLUTCH ASSY, 2.15	1							
13	1	129670-81110	CLUTCH ASSY, I=2.7	1							
14	1	129670-13600	STUD	2							
15	1	26106-080202	BOLT, M8X 20 PLATED	6							
16	1	26306-080002	NUT, M8	2							

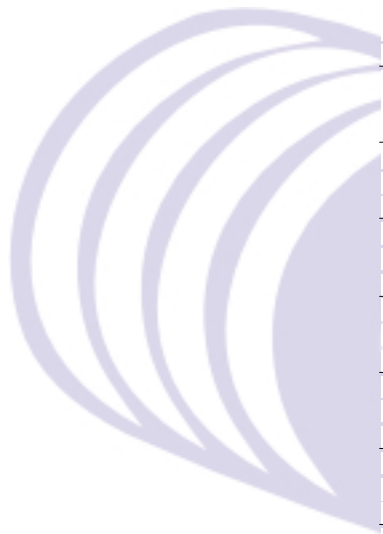

Remarks  
THIS FIGURE ARE NOT ILLUSTRATED.

テーパカップリング  
TAPER COUPLING

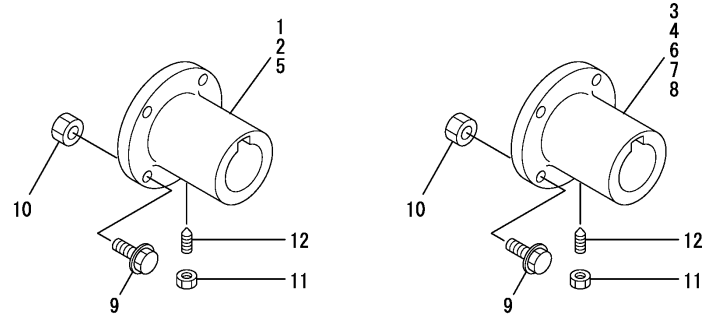

ストレートカップリング  
STRAIGHT COUPLING

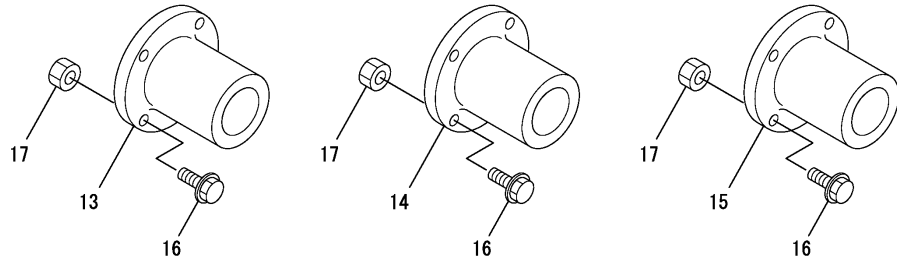

スリットカップリング  
SLIT COUPLING

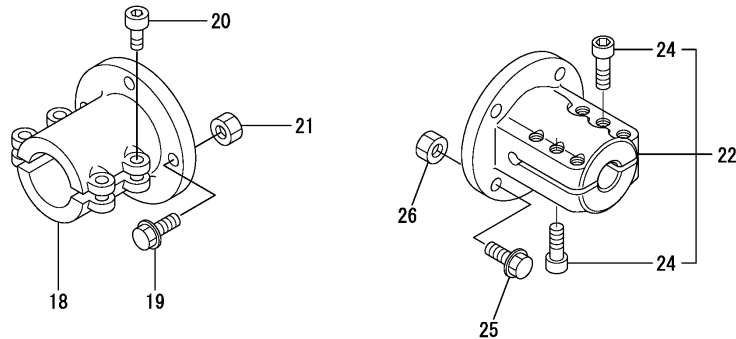

(A)=4JH5E  
(B)=  
(C)=

(D)=  
(E)=  
(F)=

No.	Lev.	Parts No.	Description	Q'ty						I	R
				(A)	(B)	(C)	(D)	(E)	(F)		
1	1	129171-85900	COUPLING, TAPER 32	1							
2	1	129670-85900	COUPLING, TAPER 34	1							
3	1	129473-85900	COUPLING, TAPER 38	1							
4	1	48110-028071	COUPLING, TAPER 28	1							
5	1	48110-032502	COUPLING, 30	1							
6	1	48110-030061	COUPLING, D29.5	1							
7	1	48110-032065	COUPLING, TAPER 32	1							
8	1	48110-034071	COUPLING, TAPER 34	1							
9	1	26106-100322	BOLT, M10X 32 PLATED	4							
10	1	26706-100002	NUT, M10	4							
11	1	26756-080002	NUT, LOCK M8	1							
12	1	48110-032411	SCREW	1							
13	1	105583-85900	COUPLING, 22	1							
14	1	129470-85900	COUPLING	1							
15	1	129673-85100	CUPLING STRAIGHT ZF	1							
16	1	26106-100322	BOLT, M10X 32 PLATED	4							
17	1	26706-100002	NUT, M10	4							
18	1	104214-83980	COUPLING	1							
19	1	26106-100322	BOLT, M10X 32 PLATED	4							
20	1	26450-080302	BOLT, M8X 30	4							
21	1	26706-100002	NUT, M10	4							
22	1	129470-83750	COUPLING ASSY	1							
24	2	26450-120402	BOLT, M12X 40	6							
25	1	26106-100322	BOLT, M10X 32 PLATED	4							
26	1	26706-100002	NUT, M10	4							

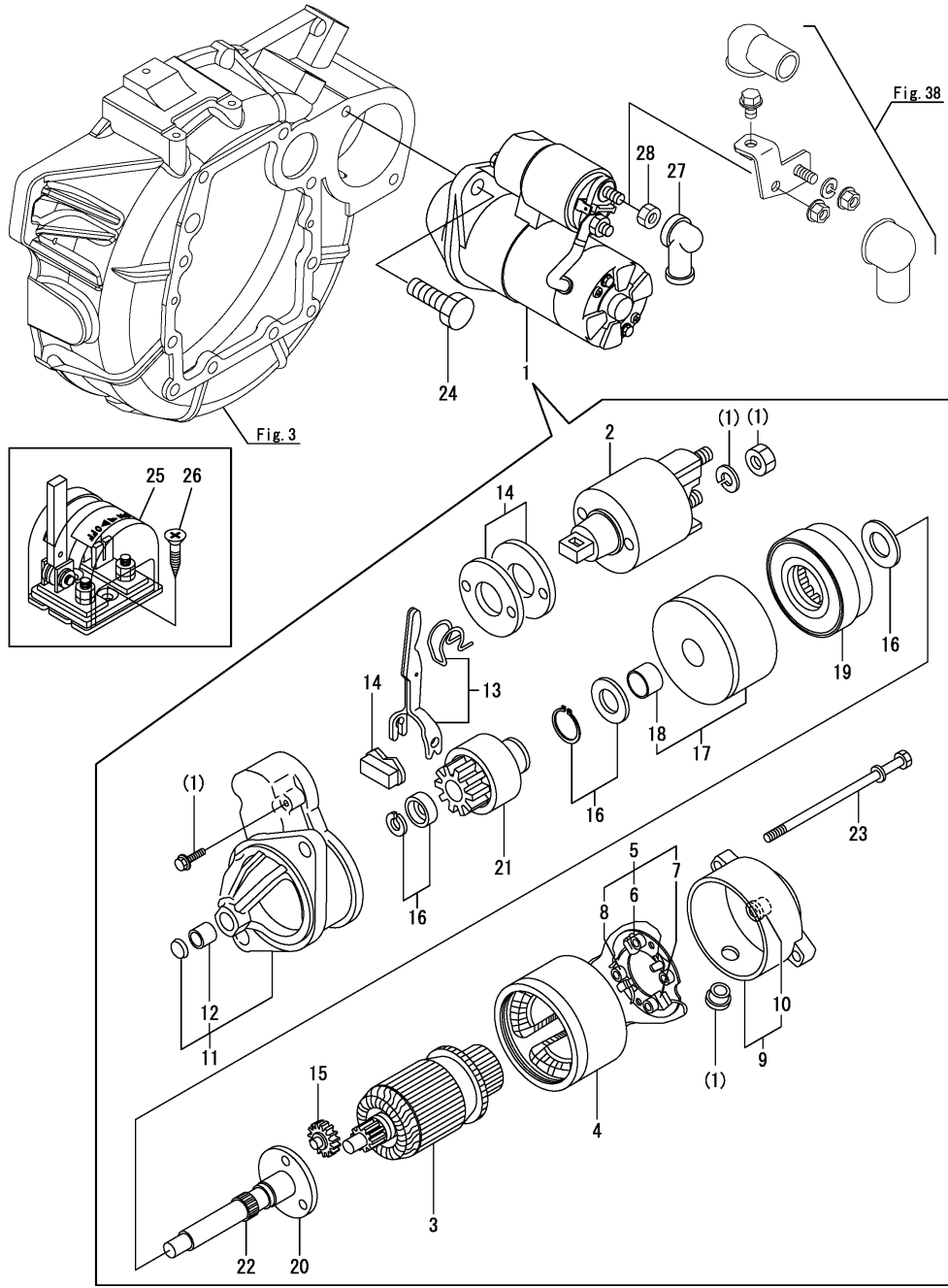

No.	Lev.	Parts No.	Description	Q'ty						I	R
				(A)	(B)	(C)	(D)	(E)	(F)		
1	1	129608-77010	STARTER ASSY	1							
2	2	129698-77020	SWITCH ASSY, MAGNET	1							
3	2	129698-77101	ARMATURE ASSY	1							
4	2	129608-77110	YOKE ASSY	1							
5	2	129698-77120	HOLDER ASSY, BRUSH	1							
6	3	129698-77140	BRUSH SET	1							
7	3	129698-77130	BRUSH	2							
8	3	129698-77150	SPRING, BRUSH	4							
9	2	129698-77161	COVER ASSY, STARTER	1							
10	3	129698-77170	BEARING, REAR COVER	1							
11	2	129698-77260	CASE ASSY, GEAR	1							
12	3	X2114535200	METAL, STARTER	1							
13	2	129698-77270	LEVER SET, SHIFT	1							
14	2	129698-77280	COVER KIT, DUST	1							
15	2	129698-77240	GEAR, PLANETARY	3							
16	2	129698-77250	WASHER SET	1							
17	2	129698-77180	BRACKET, CENTER P	1							
18	3	129698-77190	BRACKET, CENTER	1							
19	2	129698-77200	GEAR, INTERNAL	1							
20	2	129698-77210	BRACKET, CENTER A	1							
21	2	129698-77220	PINION ASSY	1							
22	2	129698-77230	SHAFT, PINION	1							
23	2	124195-77770	BOLT, THROUGH	2							
24	1	26116-120302	BOLT, M12X 30 PLATED	2							
25	1	123310-77640	SWITCH, BATTERY	1							
26	1	22724-800380	SCREW, 8.0X38	2							
27	1	129670-77030	COVER, TERMINAL B	1							Z
		(A=E/#E17384)									
28	1	26756-080002	NUT, LOCK M8	1							Z
		(A=E/#E17384)									

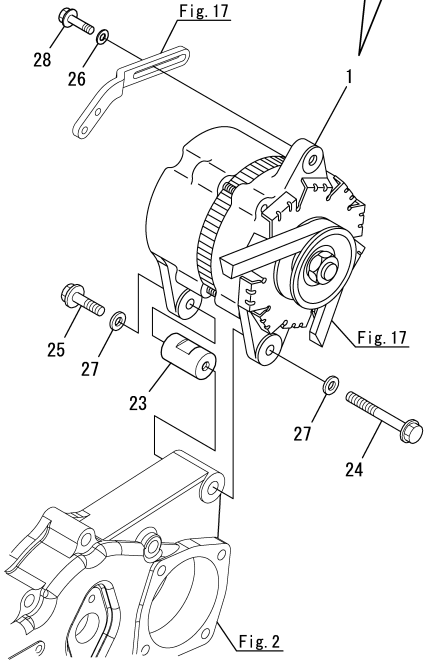
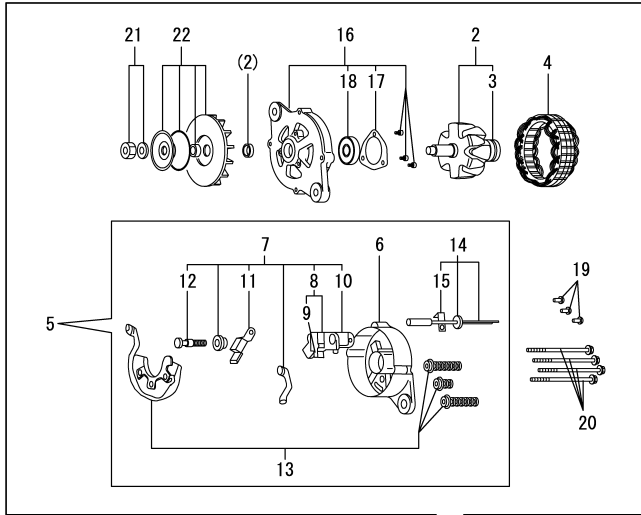

(A)=4JH5E  
(B)=  
(C)=

(D)=  
(E)=  
(F)=

No.	Lev.	Parts No.	Description	Q'ty						I	R
				(A)	(B)	(C)	(D)	(E)	(F)		
1	1	119573-77201 (A=E14236)	ALTERNATER(12V-80A	1							Z
2	2	XL180G61000	ROTOR ASSY	1							
3	3	119129-77320	BEARING, BALL	1							
4	2	XL180120000	STATOR ASSY	1							
5	2	XL180G63006	COVER ASSY, REAR	1							
6	3	XL180G13012	COVER, REAR	1							
7	3	XL180G43150	BRUSH ASSY,REGULATOR	1							
8	4	XL155G1330	BRUSH ASSY	1							
9	5	XL225G1325	BRUSH SET	2							
10	4	124080-77390	REGULATOR ASSY	1							
11	4	XL225431800	CONDENSER ASSY	1							
12	4	124080-77520	BOLT M5	2							
13	3	XL1808320	DIODE ASY	1							
14	3	119129-77250	WIRE, LEAD	1							
15	4	119129-77260	CLAMP	1							
16	2	XL235340110	COVER ASSY, FRONT	1							
17	3	XL150M14041	RETAINER	1							
18	3	X6303BM0000	BEARING, BALL	1							
19	2	119129-77930	SCREW KIT	1							
20	2	119129-77890	BOLT, THROUGH	4							
21	2	119129-77900	NUT ASSY, PULLEY	1							
22	2	XL180G85001	PULLEY ASSY	1							
23	1	129670-77350	PIECE	1							
24	1	129670-77370	BOLT 10X 70	1							
25	1	129670-77380	BOLT 10X 30	1							
26	1	22137-080000	WASHER, 8	1							
27	1	22137-100000	WASHER, 10	2							
28	1	26106-080252	BOLT, M8X 25 PLATED	1							

Remarks  
\*This item is applicable to [(A)=E14235] or previous machines.  
Refer to Fig.48.



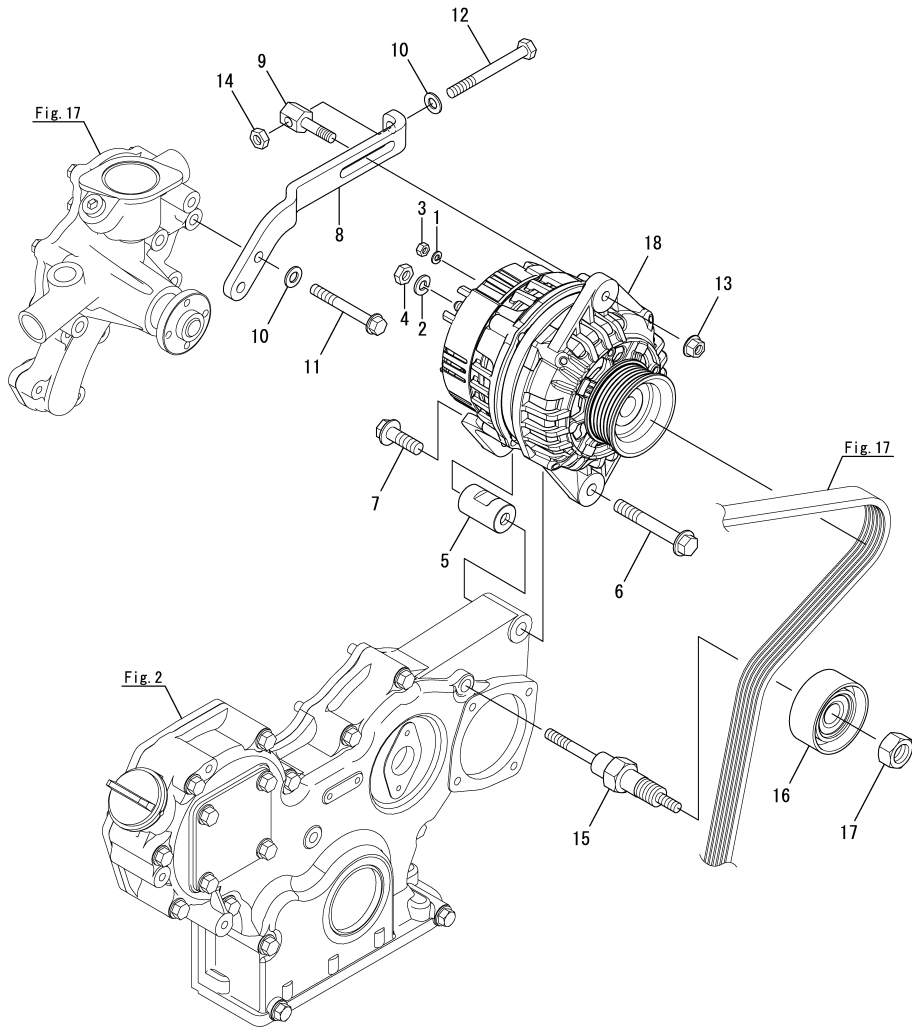

(A)=4JH5E  
(B)=  
(C)=

(D)=  
(E)=  
(F)=

No.	Lev.	Parts No.	Description	Q'ty						I	R
				(A)	(B)	(C)	(D)	(E)	(F)		
1	1	22217-050000	WASHER, SPRING 5	2							
2	1	22217-080000	WASHER, SPRING 8	1							
3	1	26716-050002	NUT, M5	2							
4	1	26756-080002	NUT, LOCK M8	1							
5	1	129670-77350	PIECE	1							
6	1	129670-77370	BOLT 10X 70	1							
7	1	129670-77380	BOLT 10X 30	1							
8	1	129271-77631	ADJUSTER, BELT	1							
9	1	129271-77641	BOLT,ADJUSTER	1							
10	1	22137-080000	WASHER, 8	2							
11	1	26106-080652	BOLT, M8X 65 PLATED	1							
12	1	26116-080804	BOLT, M8X 80 PLATED	1							
13	1	26366-080002	NUT, M8	1							
14	1	26716-080002	NUT, M8	1							
15	1	129271-77651	BOLT,IDLER BELT	1							
16	1	129271-77660	IDLER ASSY,BELT 25.5	1							
17	1	26716-160002	NUT, M16	1							
18	1	128990-77250	ALTERNATOR, 12V-120A	1							W

(A=E14236)

Remarks  
\*This item is applicable to [(A)=E14236] or following machines.  
Refer to Fig.35.

(A)=4JH5E  
(B)=  
(C)=

(D)=  
(E)=  
(F)=

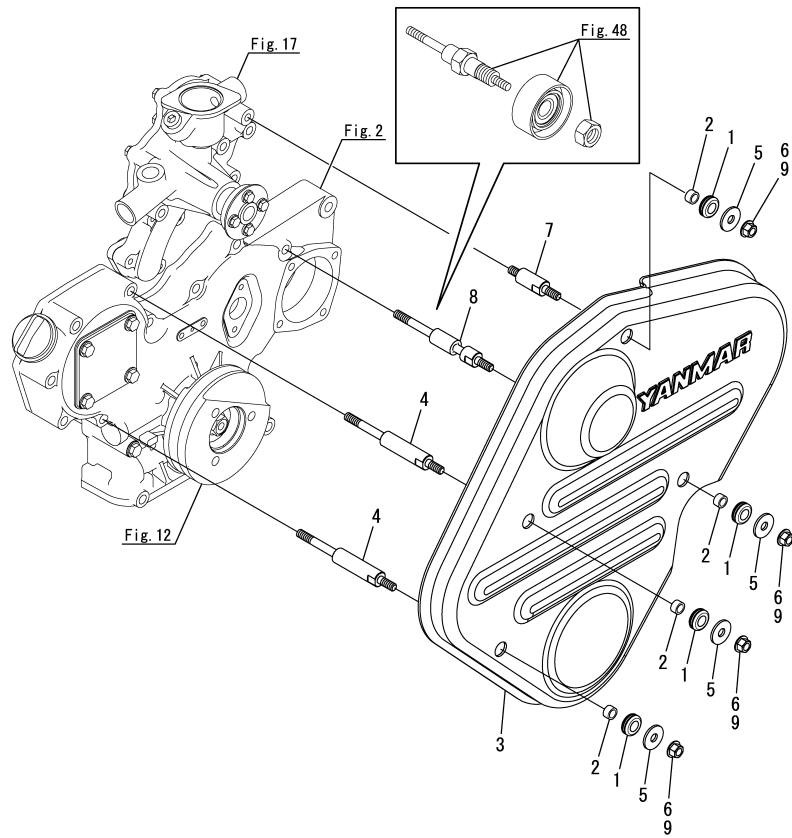

No.	Lev.	Parts No.	Description	Q'ty						I	R
				(A)	(B)	(C)	(D)	(E)	(F)		
1	1	128990-77610	GROMMET	4							
2	1	128990-77430	COLLAR	4							
3	1	129271-77401	COVER, BELT	1							
4	1	129271-77410	BOLT	2							
4-1	1	129271-77411	BOLT,BELT COVER	2						S	1
(A=E12749)											
5	1	22157-080000	WASHER, 8	4							
6	1	26306-080002	NUT, M8	4							Z
(A=E14236)											
7	1	129271-77420	BOLT	1							
7-1	1	129271-77421	BOLT,BELT COVER	1							S 1
(A=E12749)											
8	1	129271-77430	BOLT	1							Z
(A=E14236)											
9	1	26366-080002	NUT, M8	4							W
(A=E14236)											

Remarks  
(1)Valeo generator spec.

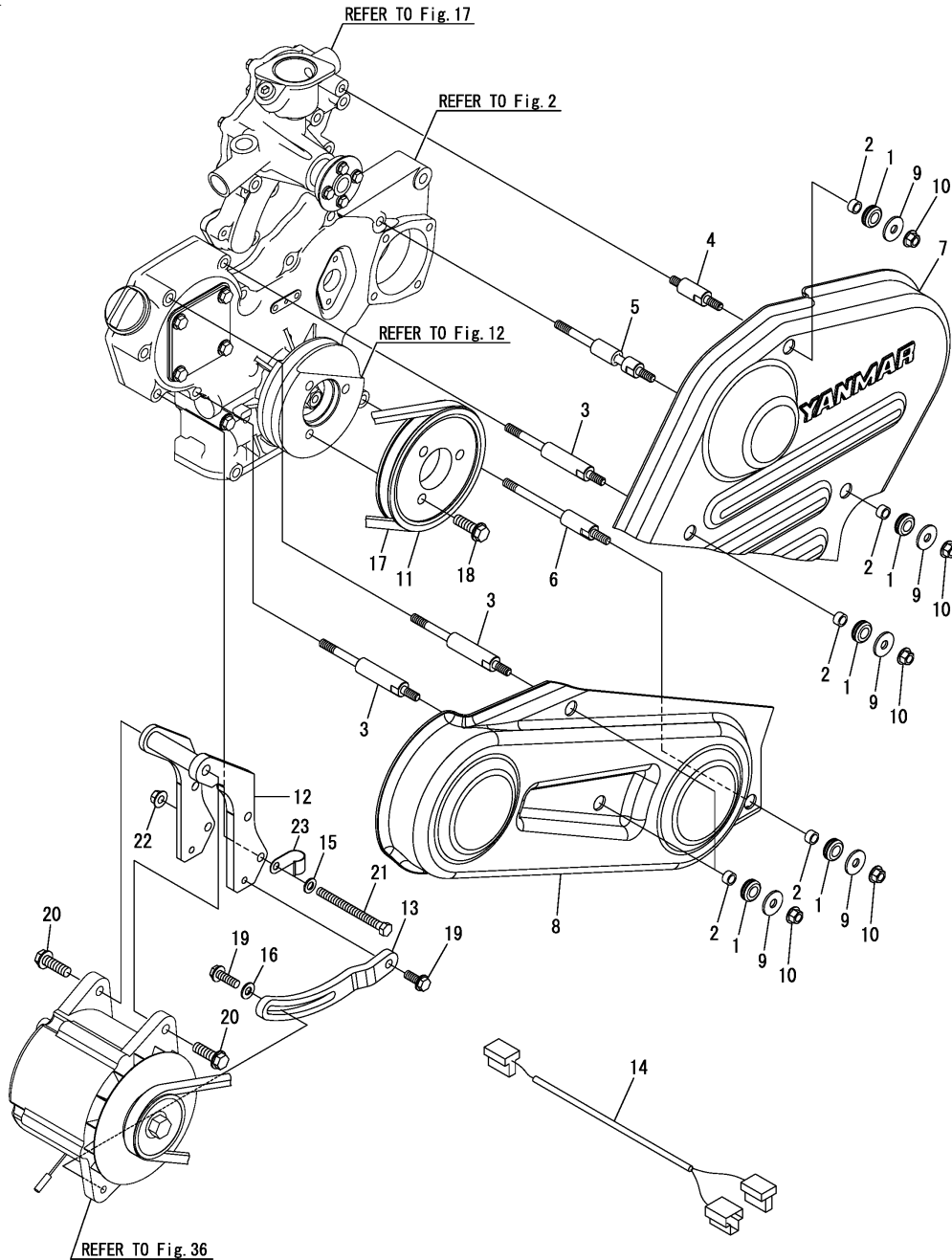
 (A)=4JH5E  
 (B)=  
 (C)=

 (D)=  
 (E)=  
 (F)=

No.	Lev.	Parts No.	Description	Q'ty						I	R
				(A)	(B)	(C)	(D)	(E)	(F)		
1	1	128990-77610	GROMMET	6							
2	1	128990-77430	COLLAR	6							
3	1	129271-77410	BOLT	3							
4	1	129271-77420	BOLT	1							
5	1	129271-77430	BOLT	1							
6	1	129271-77440	BOLT	1							
7	1	129271-77501	COVER, BELT	1							
8	1	129271-77510	COVER, BELT	1							
9	1	22157-080000	WASHER, 8	6							
10	1	26306-080002	NUT, M8	6							
11	1	129271-21350	V-PULLEY	1							
12	1	129271-77311	BRACKET,ALTERNATOR	1							
13	1	129271-77330	ADJUSTER	1							
14	1	129271-77931	HARNES,ALTERNATOR	1							
15	1	22137-080000	WASHER, 8	2							
16	1	22137-080000	WASHER, 8	1							
17	1	25132-003800	V-BELT, A38	1							
18	1	26106-100302	BOLT, M10X 30 PLATED	3							
19	1	26106-080252	BOLT, M8X 25 PLATED	2							
20	1	26106-100302	BOLT, M10X 30 PLATED	2							
21	1	26116-080904	BOLT, M8X 90 PLATED	2							
22	1	26306-080002	NUT, M8	2							
23	1	129150-03100	RETAINER, PIPE	1							

(A)=4JH5E

(B)=

(C)=

(D)=

(E)=

(F)=

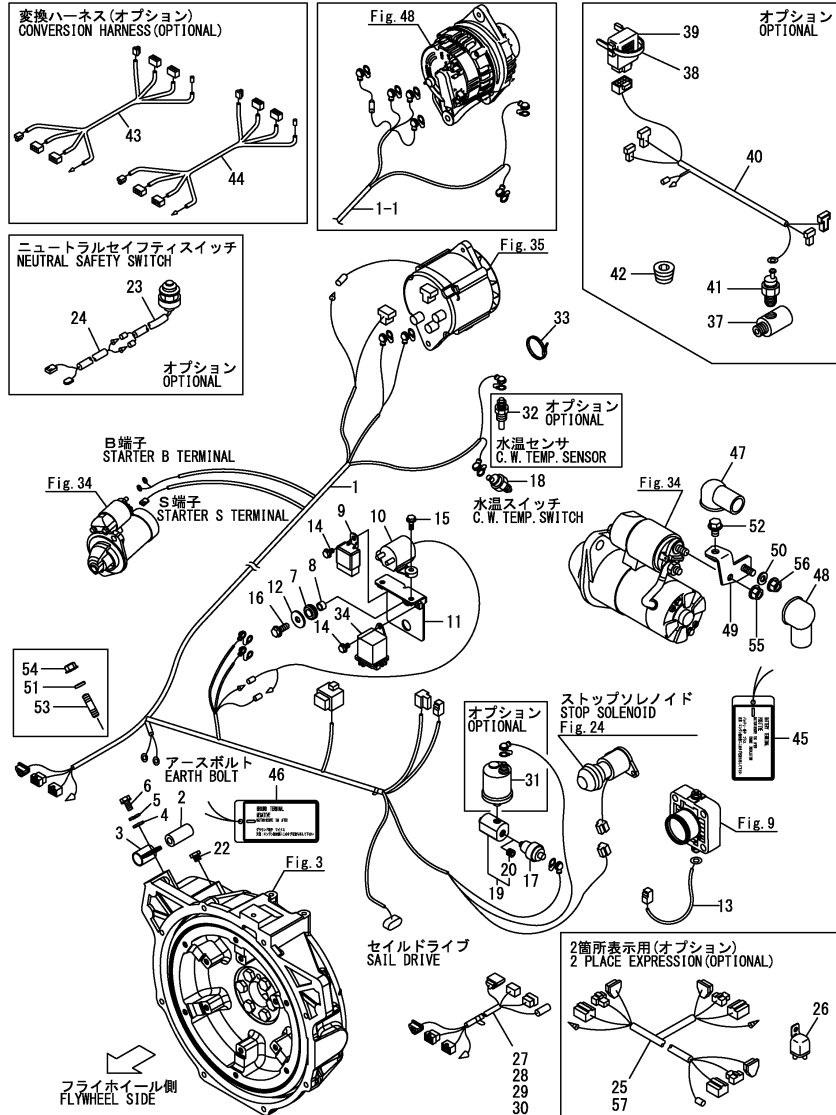

No.	Lev.	Parts No.	Description	Q'ty						I	R
				(A)	(B)	(C)	(D)	(E)	(F)		
1	1	129670-77920	HARNESS, WIRE ENGINE	1							1
1-1	1	129670-77921	HARNESS, ENGINE	1							S 2
(A=E/#E14236)											
2	1	129670-77940	PROTECTOR	1							
3	1	124070-77950	CLAMP	1							
4	1	22137-080000	WASHER, 8	1							Z
(A=E/#E17384)											
5	1	22217-080000	WASHER, SPRING 8	1							Z
(A=E/#E17384)											
6	1	26106-080162	BOLT, M8X 16 PLATED	1							Z
(A=E/#E17384)											
7	1	128990-77610	GROMMET, M8	2							
8	1	128990-77430	COLLAR, BRACKET	2							
9	1	119247-77100	RELAY, POWER SN2213	1							
10	1	128990-77550	RELAY, MAGNET	1							
11	1	128990-77400	BRACKET, RELAY	1							
12	1	22157-080000	WASHER, 8	2							
13	1	129271-77921	HARNESS, AIR HEATER	1							
14	1	26106-060102	BOLT, M6X 10 PLATED	2							
15	1	26106-060162	BOLT, M6X 16 PLATED	2							
16	1	26106-080202	BOLT, M8X 20 PLATED	2							
17	1	121252-39450	SWITCH, HYDRAULIC	1							
18	1	120130-91370	SWITCH, TEMPERATURE	1							
19	1	129670-39600	DAMPER ASSY, R1/8	1							
20	2	23875-010000	PLUG, R01	1							
22	1	23887-180002	PLUG, 18	1							
23	1	120270-77102	SWITCH, SAFETY	1							
24	1	129570-77960	HARNESS, SWITCH	1							
25	1	129574-77980	HARNESS, WIRE	1							Z 6
(A=E/#E14236)											
26	1	119773-91850	RELAY, DC12V	1							Z
(A=E/#E14236)											
27	1	129574-77710	HARNESS, WIRE 4M	1							
27-1	1	164100-22720	HARNESS, WIRE 4M	1							S 5
(A=E/#E14236)											
28	1	129574-77720	HARNESS, WIRE 6M	1							
28-1	1	164100-22730	HARNESS, WIRE 6M	1							S 5
(A=E/#E14236)											
29	1	128391-77720	HARNESS, WIRE	1							
29-1	1	164100-22830	HARNESS, EXT 6M	1							S 5
(A=E/#E14236)											
30	1	129574-77740	HARNESS, WIRE 10M	1							
30-1	1	164100-22740	HARNESS, WIRE 10M	1							S 5
(A=E/#E14236)											
31	1	119773-91650	SENSOR, HYDRAULIC	1							
32	1	119773-91700	SENDER, TEMPERATURE	1							
33	1	194250-51660	BAND, NYLON 250	1							
33-1	1	29622-250001	BAND, RF250	1							R
(A=*2014.06)											
33-2	1	128990-59890	BAND, 200	1							S
(A=E/#E14236)											

**Remarks**

- (1)YAZAKI.
- (2)DEUTSCH (Valeo generator spec).
- (3)For MEDALLION panel (Conversion from VDO panel).
- (4)For VDO panel (Conversion to the Valeo generator).
- (5)Valeo generator spec.
- (6)For VDO panel.
- (7)For MEDALLION panel.

(A)=4JH5E

(B)=

(C)=

(D)=

(E)=

(F)=

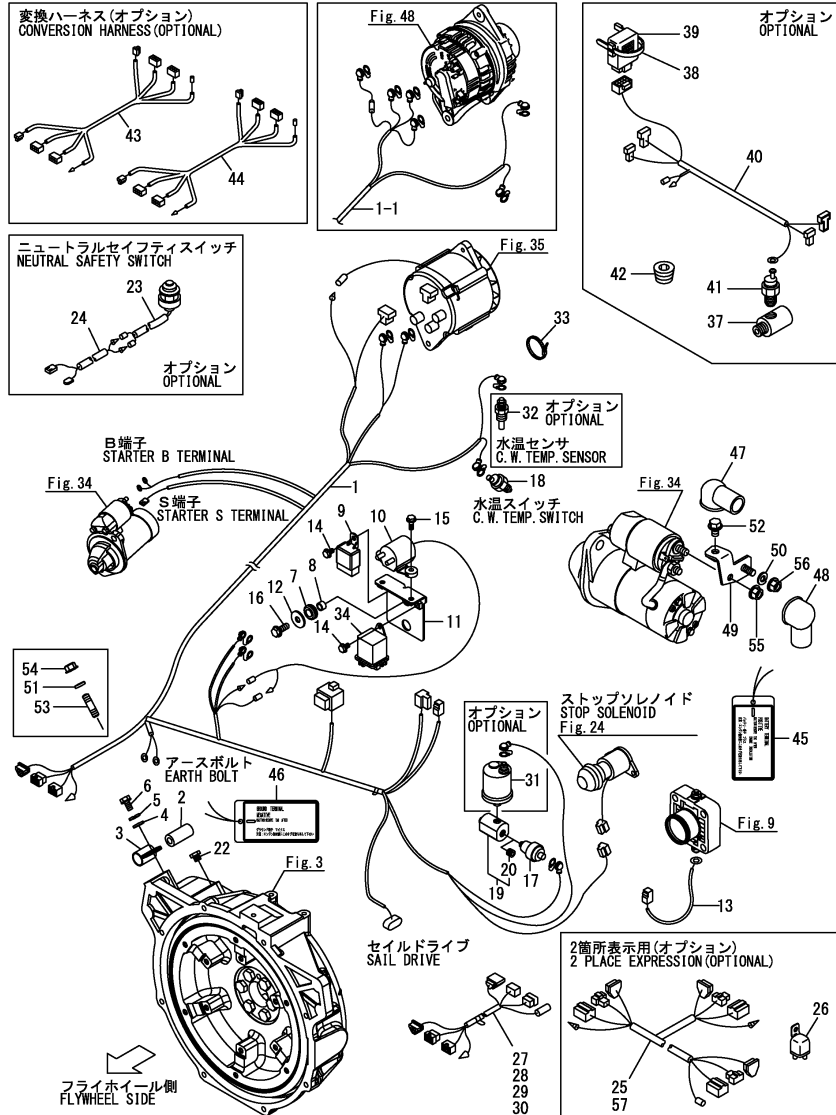

No.	Lev.	Parts No.	Description	Q'ty						I	R
				(A)	(B)	(C)	(D)	(E)	(F)		
34	1	128990-77910	RELAY, GROW	1							
37	1	129671-49990	JOINT, R3/8	1							
38	1	194250-51660	BAND, NYLON 250	3							
39	1	119575-77071	CONTROLLER, RELAY	1							
40	1	129670-77980	HARNESS, CONTROLLER	1							
41	1	124616-91370	SWITCH, TEMPERATURE	1							
42	1	23875-030000	PLUG, R03	1							
43	1	164100-23900	HARNESS, CONVERSION	1							W 3
(A=*2012.02)											
43-1	1	164100-23900	HARNESS, CONVERSION	1							Z 3
(A=E/#E14236)											
44	1	164100-23910	HARNESS, CONVERSION	1							W 4
(A=E/#E14236)											
45	1	129677-07450	LABEL, BATTERY+	1							W
(A=E/#E17384)											
46	1	129677-07460	LABEL, GROUND-	1							W
(A=E/#E17384)											
47	1	119773-77030	COVER, TERMINAL	1							W
(A=E/#E17384)											
48	1	119773-77030	COVER, TERMINAL	1							W
(A=E/#E17384)											
49	1	129675-77571	TERMINAL, BATTERY	1							W
(A=E/#E17384)											
50	1	22217-080000	WASHER, SPRING 8	1							W
(A=E/#E17384)											
51	1	22217-080000	WASHER, SPRING 8	1							W
(A=E/#E17384)											
52	1	26106-080122	BOLT, M8X 12 PLATED	1							W
(A=E/#E17384)											
53	1	26216-080202	STUD, M8X 20	1							W
(A=E/#E17384)											
54	1	26366-080002	NUT, M8	1							W
(A=E/#E17384)											
55	1	26366-080002	NUT, M8	1							W
(A=E/#E17384)											
56	1	26366-080002	NUT, M8	1							W
(A=E/#E17384)											
57	1	164100-23700	HARNESS, DUAL PANEL	1							W 7
(A=*2013.05)											

Remarks

- (1)YAZAKI.
- (2)DEUTSCH (Valeo generator spec).
- (3)For MEDALLION panel (Conversion from VDO panel).
- (4)For VDO panel (Conversion to the Valeo generator).
- (5)Valeo generator spec.
- (6)For VDO panel.
- (7)For MEDALLION panel.

(A)=4JH5E  
(B)=  
(C)=

(D)=  
(E)=  
(F)=

No.	Lev.	Parts No.	Description	Q'ty						I	R
				(A)	(B)	(C)	(D)	(E)	(F)		
1	1	196420-02790 (A=E/#16995)	AMP	1							W

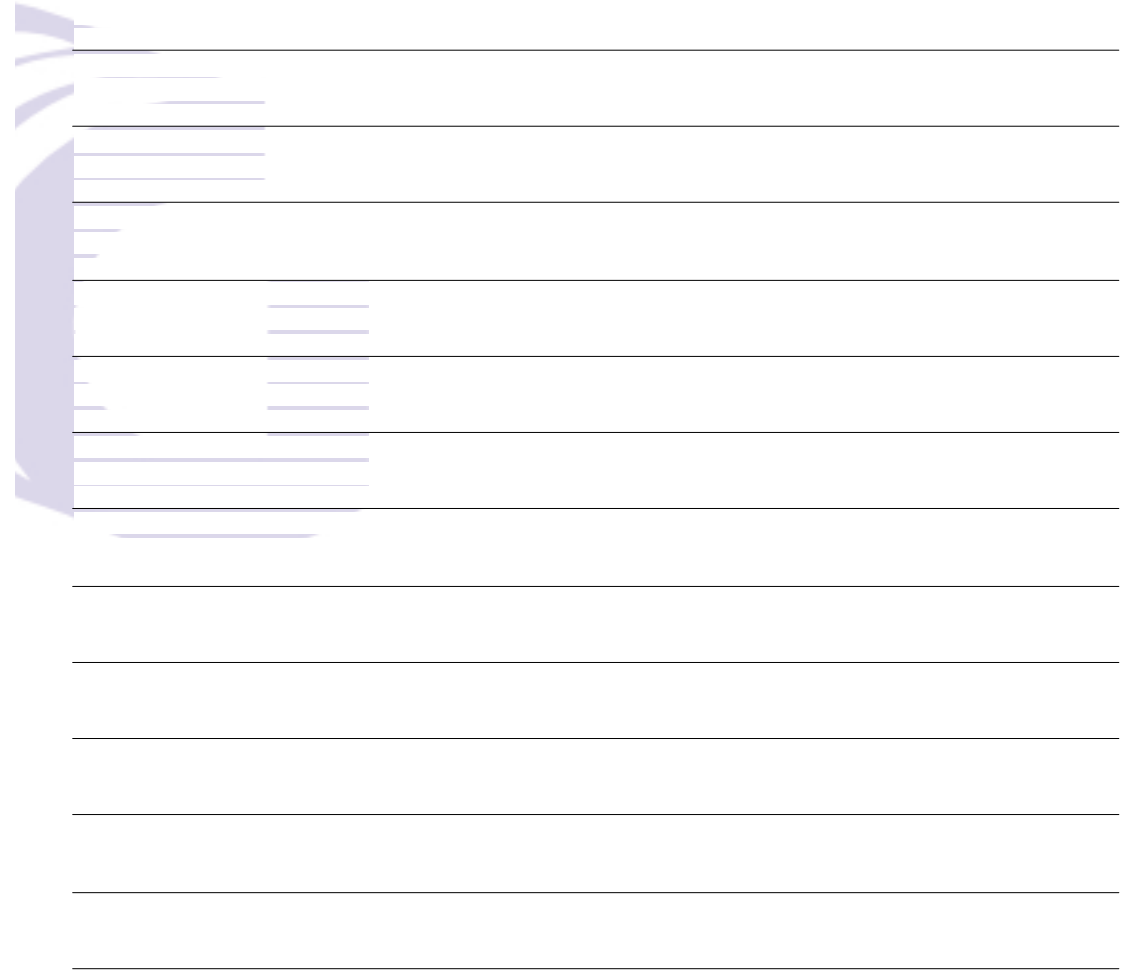
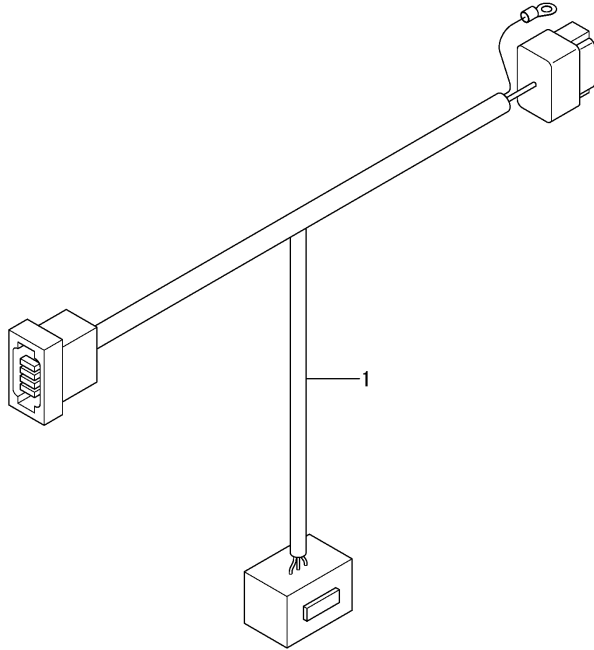

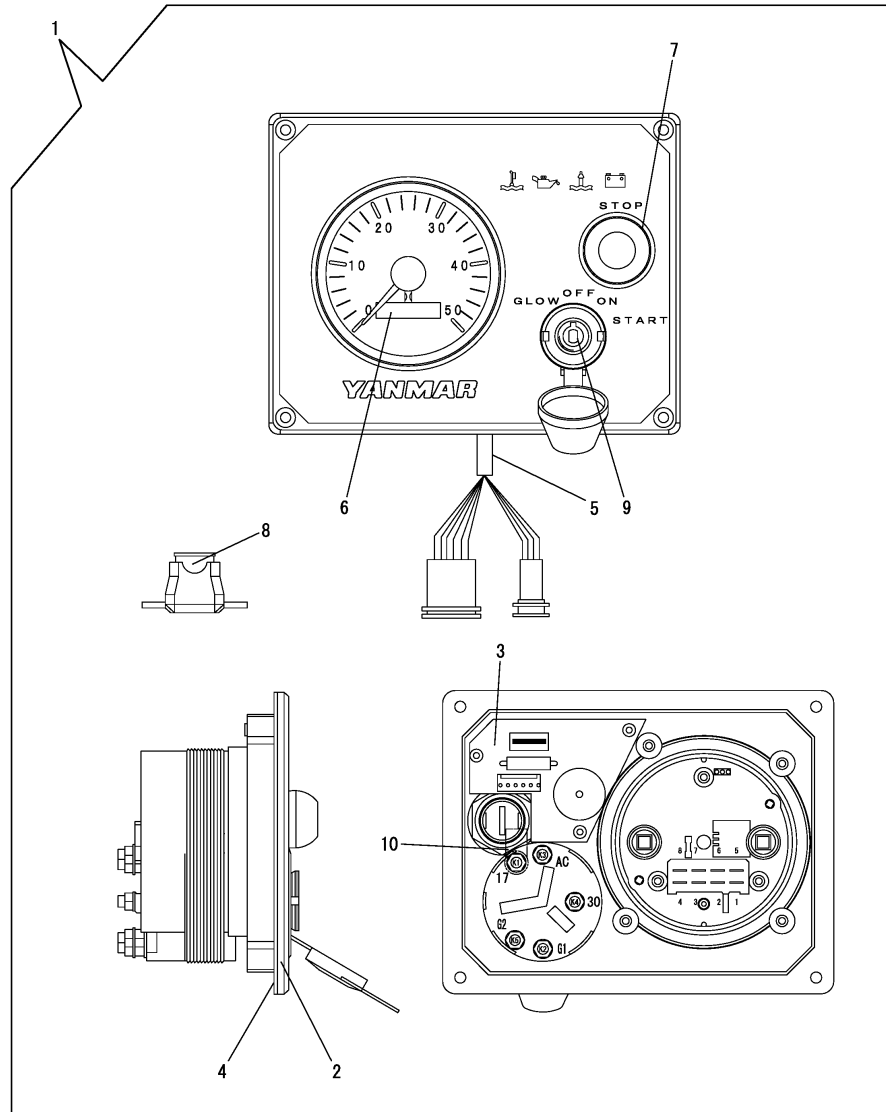

(A)=4JH5E  
(B)=  
(C)=

(D)=  
(E)=  
(F)=

No.	Lev.	Parts No.	Description	Q'ty						I	R
				(A)	(B)	(C)	(D)	(E)	(F)		
1	1	129271-91112	PANEL	1							
1-1	1	129271-91113	PANEL, INSTRUMENT B	1							N
(A=EZZZZZ)											
2	2	129271-91120	PANEL, INSTRUMENT B	1							
3	2	129271-91131	CIRCUIT WITH LED&BZR	1							
3-1	2	129271-91132	CIRCUIT WITH LED&BZR	1							N
(A=EZZZZZ)											
4	2	129271-91140	SEAL	1							
5	2	129271-91150	HARNES, WIRE	1							
6	2	129271-91210	TACHOMETER	1							
6-1	2	129271-91211	TACHOMETER (AN)10.29	1							N
(A=EZZZZZ)											
7	2	129271-91220	SWITCH, STOP	1							
8	2	129271-91230	FUSE	1							
9	2	127412-91250	SWITCH, KEY	1							
10	2	129271-91260	CAP, RUBBER M5	1							

Remarks  
\*This item is applicable to [(A)=Dec., 2011] or previous machines.  
Refer to Fig.46.



(A)=4JH5E  
(B)=  
(C)=

(D)=  
(E)=  
(F)=

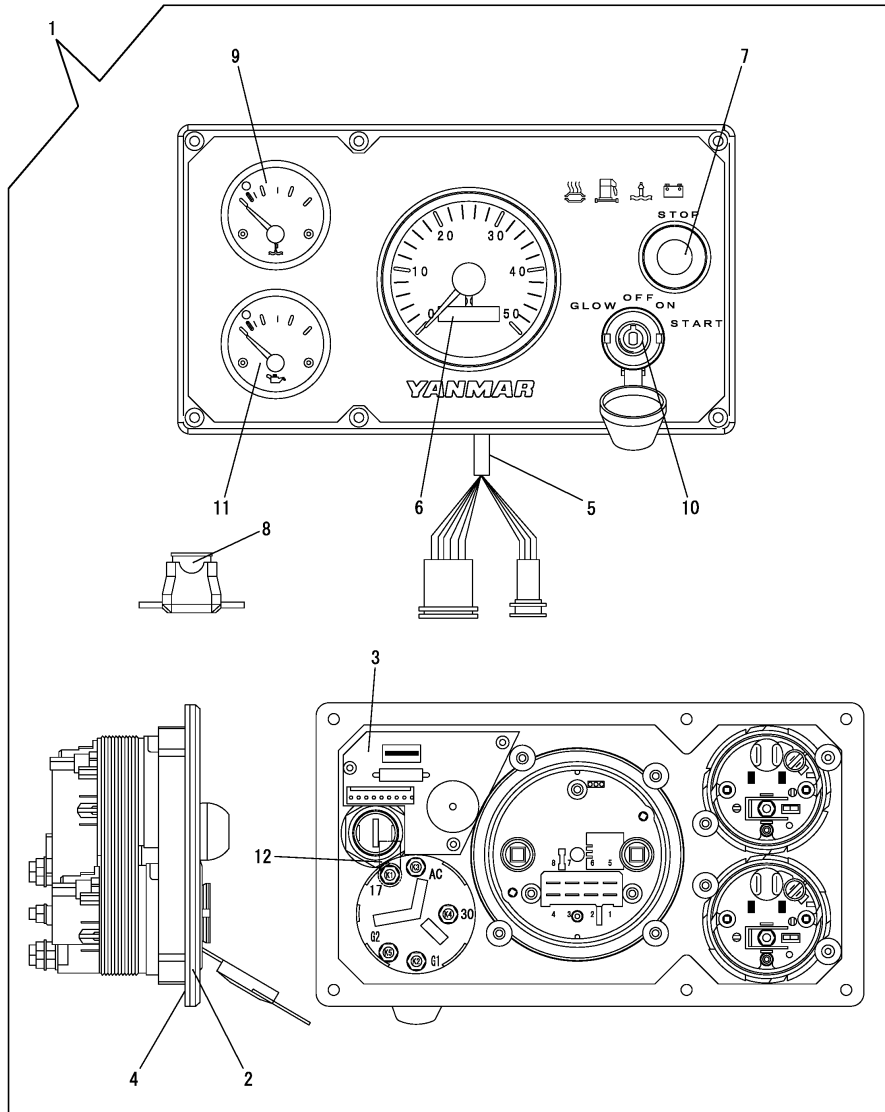

No.	Lev.	Parts No.	Description	Q'ty						I	R
				(A)	(B)	(C)	(D)	(E)	(F)		
1	1	129271-91162	PANEL	1							
1-1	1	129271-91163	PANEL, INSTRUMENT C	1							N
(A=EZZZZZ)											
2	2	129271-91170	PANEL	1							
3	2	129271-91181	CIRCUIT	1							
3-1	2	129271-91182	CIRCUIT WITH LED&BZR	1							N
(A=EZZZZZ)											
4	2	129271-91190	RUBBER, SEAL	1							
5	2	129271-91200	HARNES, WIRE	1							
6	2	129271-91210	TACHOMETER	1							
6-1	2	129271-91211	TACHOMETER (AN)10.29	1							N
(A=EZZZZZ)											
7	2	129271-91220	SWITCH, STOP	1							
8	2	129271-91230	FUSE	1							
9	2	129271-91240	THERMOMETER, WATER	1							
10	2	127412-91250	SWITCH, KEY	1							
11	2	129271-91250	GAUGE	1							
12	2	129271-91260	CAP, RUBBER M5	1							

Remarks

\*This item is applicable to [(A)=Dec., 2011] or previous machines.  
Refer to Fig.47.



(A)=4JH5E  
(B)=  
(C)=

(D)=  
(E)=  
(F)=

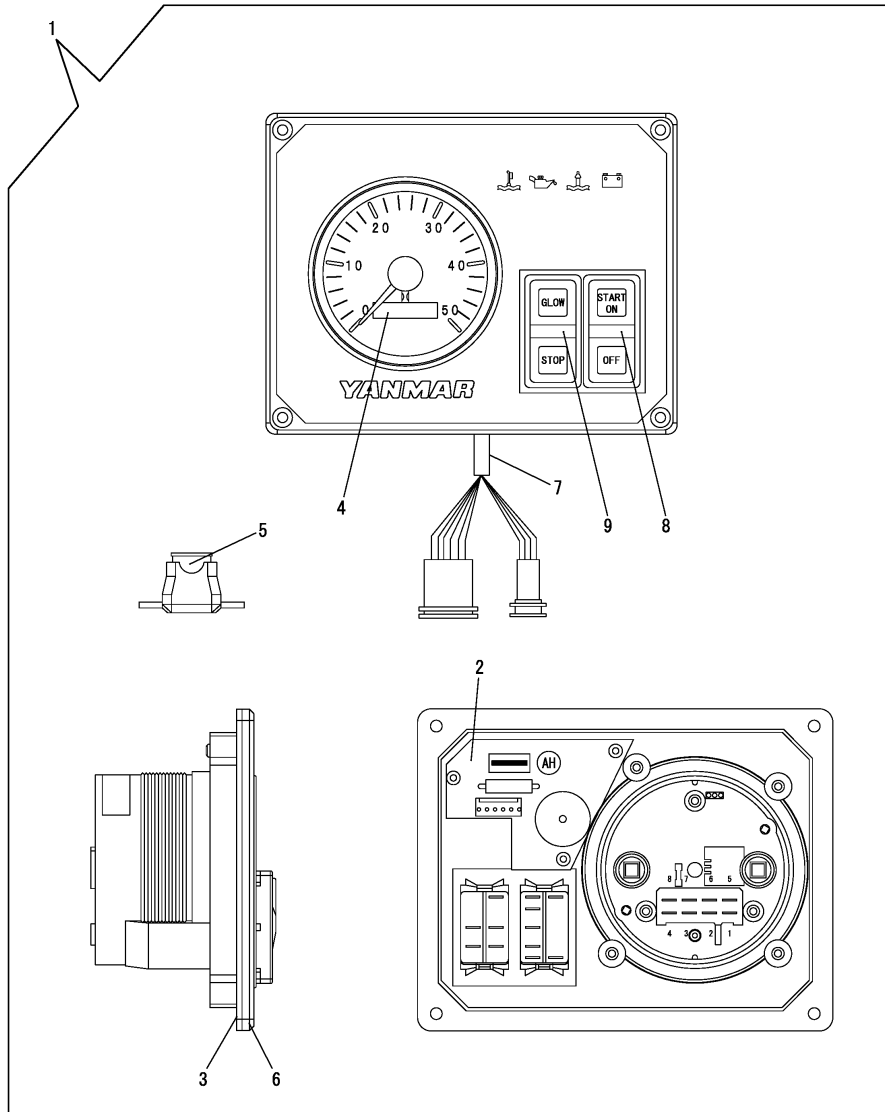

No.	Lev.	Parts No.	Description	Q'ty						I	R
				(A)	(B)	(C)	(D)	(E)	(F)		
1	1	129271-91301	PANEL	1							
1-1	1	129271-91302	PANEL,B KEYLESS	1							N
(A=EZZZZZ)											
2	2	129271-91131	CIRCUIT WITH LED&BZR	1							
2-1	2	129271-91132	CIRCUIT WITH LED&BZR	1							N
(A=EZZZZZ)											
3	2	129271-91140	SEAL	1							
4	2	129271-91210	TACHOMETER	1							
4-1	2	129271-91211	TACHOMETER (AN)10.29	1							N
(A=EZZZZZ)											
5	2	129271-91230	FUSE	1							
6	2	129271-91310	PANEL WITH COVERFOIL	1							
7	2	129271-91320	HARNES,B KEYLESS	1							
8	2	129271-91330	SWITCH,OFF/START	1							
9	2	129271-91340	SWITCH,GLOW/STOP	1							

Remarks

\*This item is applicable to [(A)=Dec., 2011] or previous machines.  
Refer to Fig.46.

(A)=4JH5E  
(B)=  
(C)=

(D)=  
(E)=  
(F)=

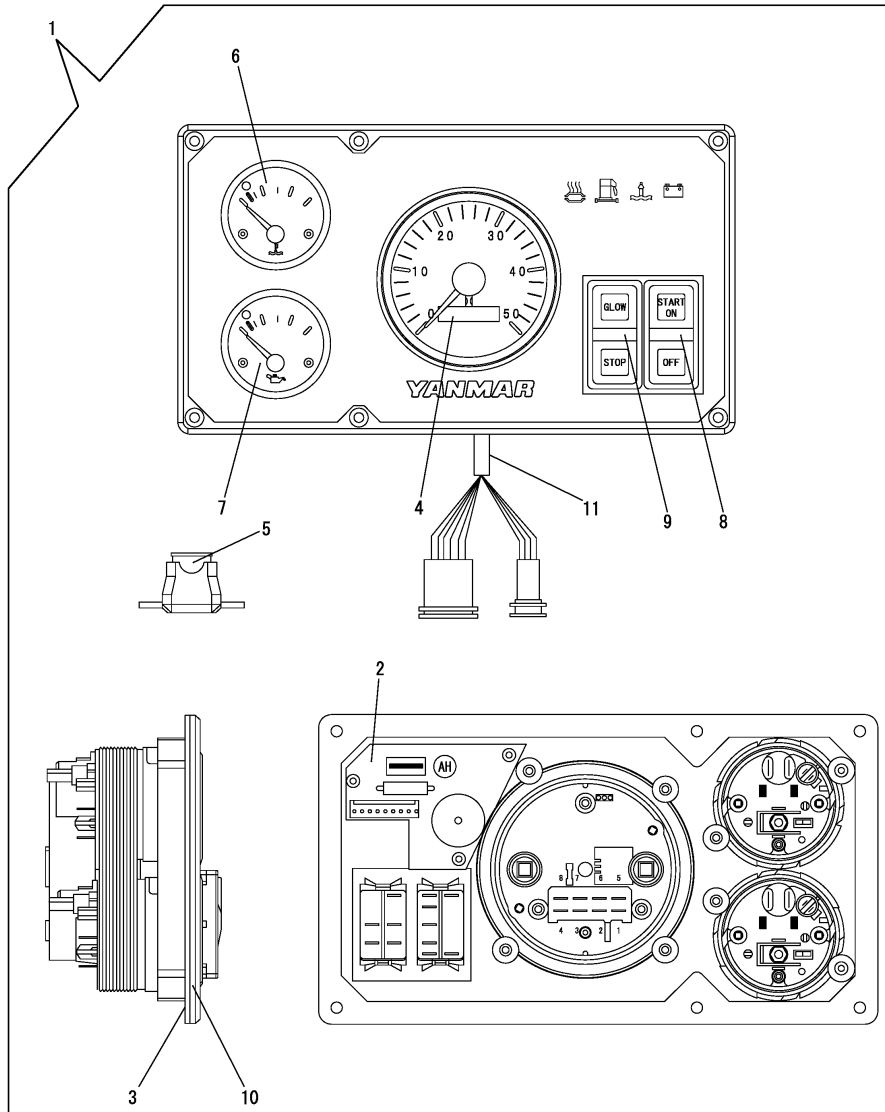

No.	Lev.	Parts No.	Description	Q'ty						I	R
				(A)	(B)	(C)	(D)	(E)	(F)		
1	1	129271-91351	PANEL	1							
1-1	1	129271-91352	PANEL,C KEYLESS	1							N
(A=EZZZZZ)											
2	2	129271-91181	CIRCUIT	1							
2-1	2	129271-91182	CIRCUIT WITH LED&BZR	1							N
(A=EZZZZZ)											
3	2	129271-91190	RUBBER, SEAL	1							
4	2	129271-91210	TACHOMETER	1							
4-1	2	129271-91211	TACHOMETER (AN)10.29	1							N
(A=EZZZZZ)											
5	2	129271-91230	FUSE	1							
6	2	129271-91240	THERMOMETER, WATER	1							
7	2	129271-91250	GAUGE	1							
8	2	129271-91330	SWITCH,OFF/START	1							
9	2	129271-91340	SWITCH,GLOW/STOP	1							
10	2	129271-91360	PANEL	1							
11	2	129271-91370	HARNES, WIRE	1							

Remarks  
\*This item is applicable to [(A)=Dec., 2011] or previous machines.  
Refer to Fig.47.

(A)=4JH5E  
(B)=  
(C)=

(D)=  
(E)=  
(F)=

1 inc. 2~15

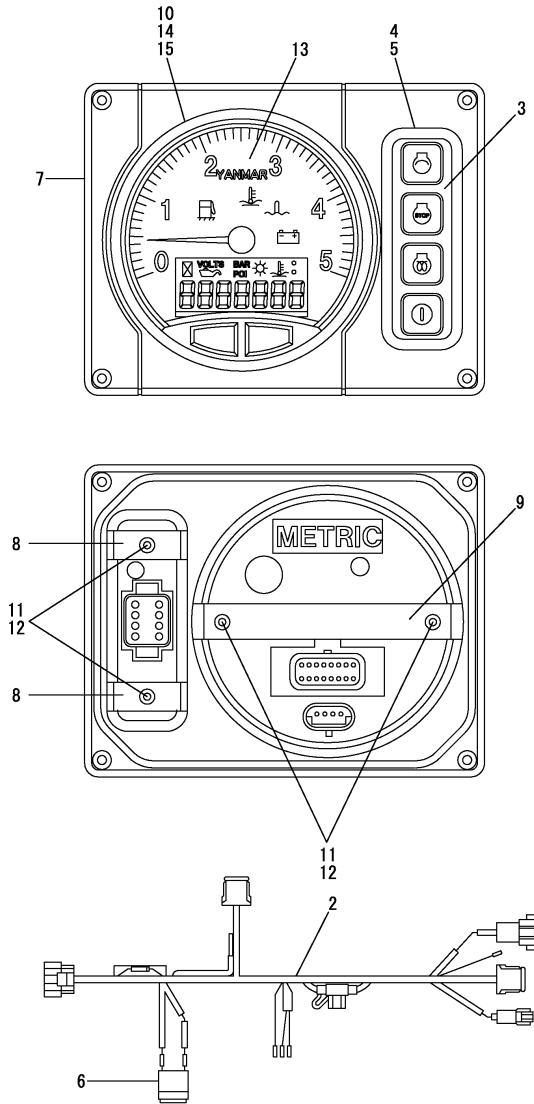

No.	Lev.	Parts No.	Description	Q'ty						I	R
				(A)	(B)	(C)	(D)	(E)	(F)		
1	1	164100-30100 (A=EXXXXX)	PANEL ASSY, B20	1							W
1-1	1	164100-30101 (A=EXXXXX)	PANEL ASSY, B20	1							N
1-2	1	164100-30102 (A=EXXXXX)	PANEL ASSY, B20 MD	1							S 1
2	2	164100-21100	HARNES, PANEL	1							
3	2	164100-31100	SWITCH, PANEL	1							
3-1	2	164100-31101	SWITCH, PANEL	1							N
4	2	164100-31150 (A=EXXXXX)	GASKET, SWITCH	1							
5	2	164100-31900	BEZEL, SWITCH BK	1							
6	2	164100-36100	BUZZER, PANEL	1							
7	2	164100-39100	FRAME, PANEL B	1							
8	2	164100-39120	BRACKET, SWITCH	2							
9	2	164100-39130	BRACKET, GAUGE 5	1							
9-1	2	164100-39131 (A=EXXXXX)	BRACKET, GAUGE 5 MD	1							S 1
10	2	164100-39150	CAP, GAUGE TERMINAL	1							
11	2	164100-39180	WASHER, LOCK	4							
12	2	164100-39190	NUT, M3.5	4							
13	2	164100-53100	GAUGE, TACH LCD 5	1							
13-1	2	164100-53101 (A=EXXXXX)	GAUGE, TACH LCD 5	1							N
13-2	2	164100-53102 (A=EXXXXX)	GAUGE, TACH LCD 5 MD	1							S 1
14	2	164100-53150	GASKET, GAUGE 5	1							
15	2	164100-53900	BEZEL, GAUGE 5 BK	1							

Remarks

\*This item is applicable to [(A)=Jan., 2012] or following machines.

Refer to Fig.39, 41.

(1)Valeo generator spec.

(A)=4JH5E

(B)=

(C)=

(D)=

(E)=

(F)=

1 inc. 3~26  
17 inc. 18~26

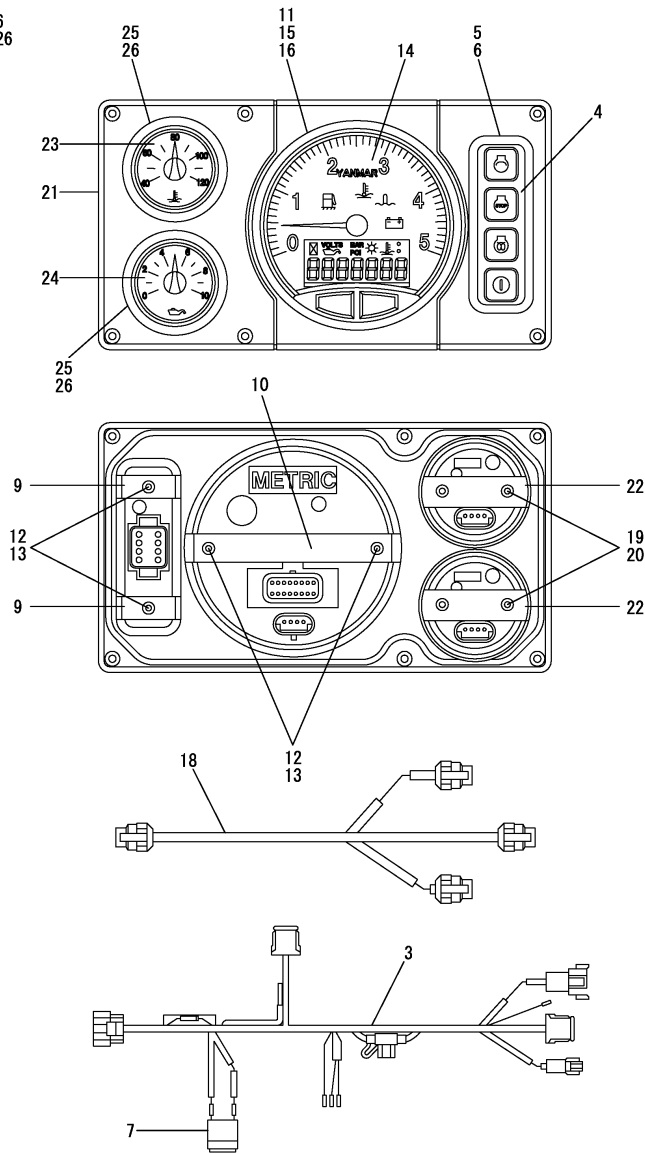

No.	Lev.	Parts No.	Description	Q'ty						I	R
				(A)	(B)	(C)	(D)	(E)	(F)		
1	1	164100-30200	PANEL ASSY, C30	1							W
		(A=EXXXXX)									
3	3	164100-21100	HARNESS, PANEL	1							
4	3	164100-31100	SWITCH, PANEL	1							
4-1	3	164100-31101	SWITCH, PANEL	1							N
		(A=EXXXXX)									
5	3	164100-31150	GASKET, SWITCH	1							
6	3	164100-31900	BEZEL, SWITCH BK	1							
7	3	164100-36100	BUZZER, PANEL	1							
9	3	164100-39120	BRACKET, SWITCH	2							
10	3	164100-39130	BRACKET, GAUGE 5	1							
10-1	3	164100-39131	BRACKET, GAUGE 5 MD	1							S 1
		(A=EXXXXX)									
11	3	164100-39150	CAP, GAUGE TERMINAL	1							
12	3	164100-39180	WASHER, LOCK	4							
13	3	164100-39190	NUT, M3.5	4							
14	3	164100-53100	GAUGE, TACH LCD 5	1							
14-1	3	164100-53101	GAUGE, TACH LCD 5	1							N
		(A=EXXXXX)									
14-2	2	164100-53102	GAUGE, TACH LCD 5 MD	1							S 1
		(A=EXXXXX)									
15	3	164100-53150	GASKET, GAUGE 5	1							
16	3	164100-53900	BEZEL, GAUGE 5 BK	1							
17	2	164100-30210	PANEL KIT, C30	1							
18	3	164100-21200	HARNESS, GAUGE 2	1							
19	3	164100-39180	WASHER, LOCK	4							
20	3	164100-39190	NUT, M3.5	4							
21	3	164100-39200	FRAME, PANEL C	1							
22	3	164100-39230	BRACKET, GAUGE 2 MD	2							
23	3	164100-53200	GAUGE, TEMP CW 2	1							
24	3	164100-53210	GAUGE, PRESS LO 2	1							
25	3	164100-53250	GASKET, GAUGE 2	2							
26	3	164100-53920	BEZEL, GAUGE 2 BK	2							

Remarks

\*This item is applicable to [(A)=Jan., 2012] or following machines.  
Refer to Fig.40, 42.

(1) Valeo generator spec.

(A)=4JH5E  
(B)=  
(C)=

(D)=  
(E)=  
(F)=

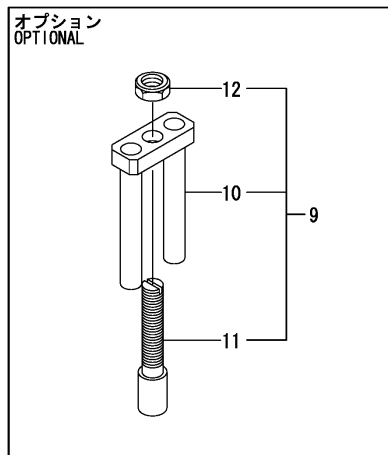
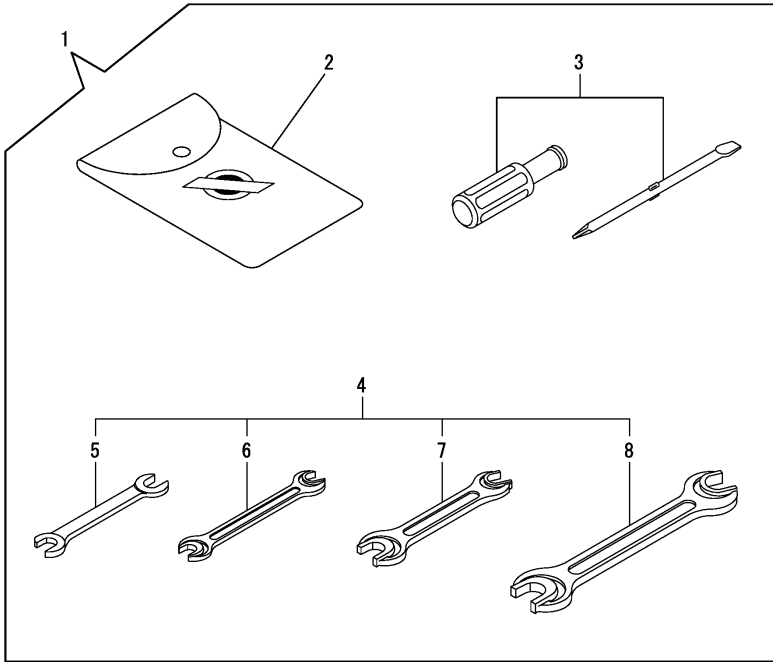

No.	Lev.	Parts No.	Description	Q'ty						I	R
				(A)	(B)	(C)	(D)	(E)	(F)		
1	1	129270-92100	BOX, TOOL	1							
2	2	129270-92600	BAG, TOOL	1							
3	2	129270-92650	DRIVER	1							
4	2	129270-92690	WRENCH ASSY	1							
5	3	129270-92610	WRENCH, 10X13	1							
6	3	129270-92620	WRENCH, 12X14	1							
7	3	129270-92630	WRENCH, 17X19	1							
8	3	129270-92640	WRENCH, 22X24	1							
9	1	129470-92300	TOOL ASSY, NOZZLE	1							
10	2	129470-92310	TOOL,NOZZLE REMOVE A	1							
11	2	129470-92320	TOOL,NOZZLE REMOVE B	1							
12	2	26716-120002	NUT, M12	1							
13	1	129671-92110	PULLER ASSY	1							
14	2	129671-92120	PULLER	1							
15	2	129671-92130	BOLT, M10X40	1							

(A)=4JH5E  
(B)=  
(C)=

(D)=  
(E)=  
(F)=

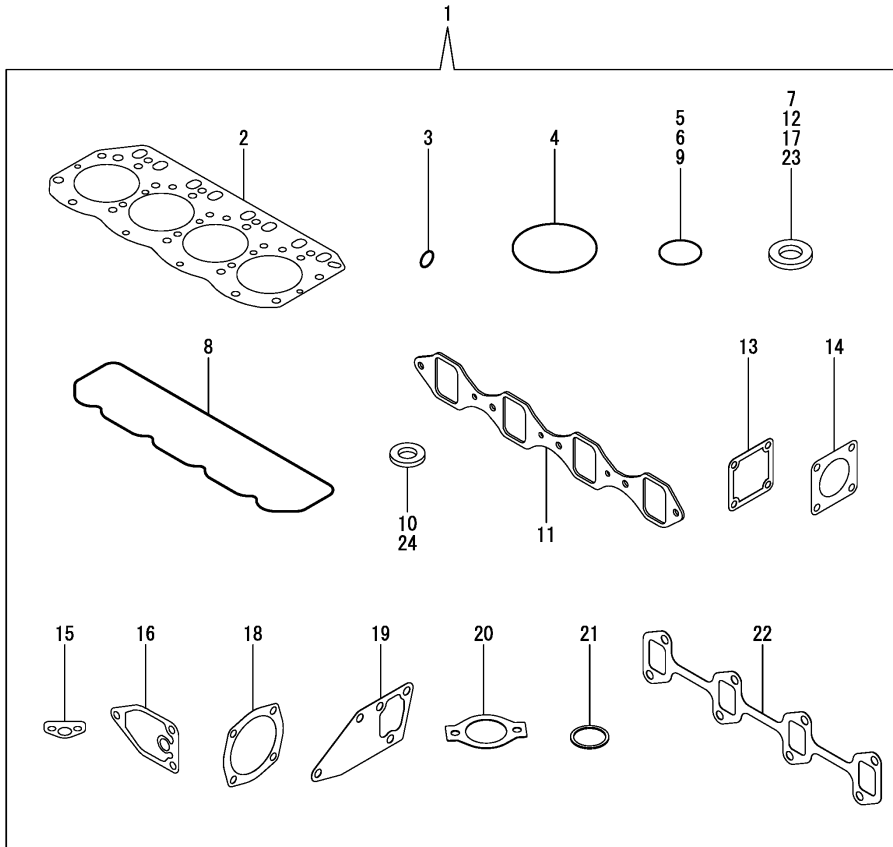

No.	Lev.	Parts No.	Description	Q'ty						I	R
				(A)	(B)	(C)	(D)	(E)	(F)		
1	1	729670-92600	GASKET SET	1							
2	2	129407-01340	GASKET, HEAD	1							
3	2	119609-32040	O-RING, P16	4							
4	2	121850-51960	O-RING	1							
5	2	24311-000320	O-RING, 1AP32.0	2							
6	2	24341-000240	O-RING, 1AS24.0	1							
7	2	22190-140002	WASHER, SEAL 14	4							
8	2	129601-11310	GASKET, BONNET	1							
9	2	24311-000120	O-RING, 1AP12.0	3							
10	2	23414-100000	GASKET, 10X1.0	1							
11	2	129470-12130	GASKET, MANIFOLD	1							
12	2	22190-080002	WASHER, SEAL 6	4							
13	2	129150-77511	GASKET	1							
14	2	129472-18090	GASKET	1							
15	2	129150-35042	GASKET	1							
16	2	129150-35111	GASKET	1							
17	2	22190-100002	WASHER, SEAL 10	2							
18	2	129150-01881	GASKET	2							
18-1	2	129C26-01890	GASKET, HO-P	2							R
		(A=EXXXXX)									
19	2	129486-42050	GASKET, WATER PUMP	1							
20	2	129795-49551	GASKET	1							
21	2	129470-49810	GASKET, THERMOSTAT	1							
22	2	129550-13110	GASKET	1							
23	2	22190-120002	WASHER, SEAL 12	8							
24	2	23414-080000	GASKET, 8X1.0	1							

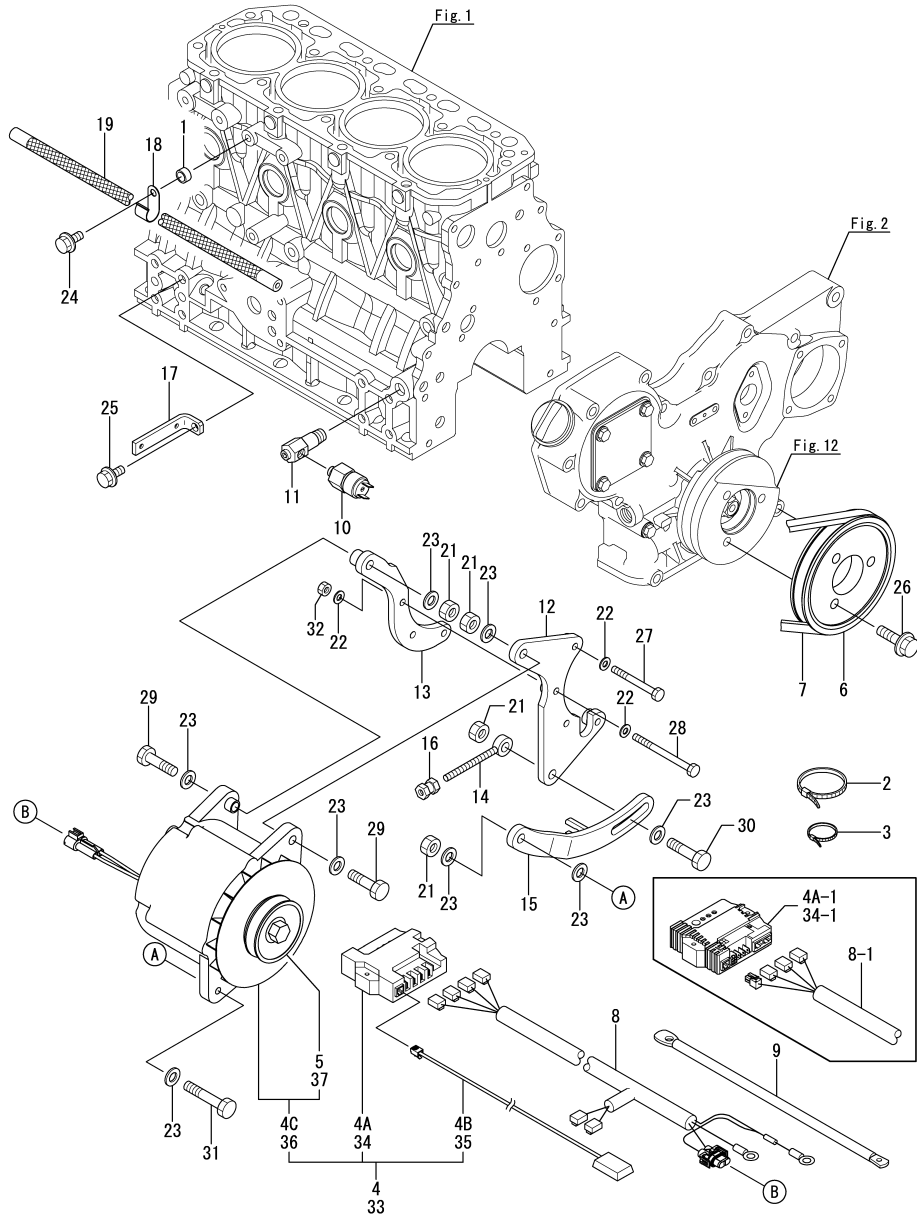

(A)=4JH5E

(B)=

(C)=

(D)=

(E)=

(F)=

No.	Lev.	Parts No.	Description	(A)	(B)	(C)	Q'ty	(D)	(E)	(F)	I	R
1	1	129301-34830	SPACER	1								
2	1	194250-51660	BAND, NYLON 250	1								
2-1	1	29622-250001	BAND, RF250	1								R
(A=*2011.07.)												
3	1	121750-59890	BAND, NYLON	2								
4	1	129271-77220	ALTERNATOR, 12V-130A	1								
4-1	1	129271-77221	ALTERNATOR ASSY,12V	1							F	1
(A=*2015.01.)												
4A	2	129271-77600	REGULATOR ASSY,12V	1								W
(A=*2011.07.)												
4A-1	2	129271-77720	REGULATOR ASSY,ALPHA	1							F	2
(A=*2015.01.)												
4B	2	129271-77620	HARNES, BATT SENSING	1								W
(A=*2011.07.)												
4C	2	129271-77580	ALTERNATOR, 12V-130A	1								W
(A=*2011.07.)												
5	3	129271-77240	PULLEY,ALTERNATOR	1								
6	1	129271-77250	PULLEY,CRANK	1								
7	1	129271-77260	BELT,6PK1060	1								
8	1	129271-77270	WIREHARNES,ALTERNAT	1								
8-1	1	129271-77271	HARNES, WIRE ALTERNA	1							F	2
(A=*2015.01.)												
9	1	129271-77280	GROUND CABLE	1								
10	1	129271-77290	SWITCH,OIL PRESSURE	1								
11	1	129271-77320	DAMPER CMP(R 1/4	1								
12	1	129271-77340	BRACKET,ALT FRONT	1								
12-1	1	129271-77341	BRACKET,ALTERNATOR F	1								S
(A=E14236)												
13	1	129271-77350	BRACKET,ALT REAR	1								
13-1	1	129271-77351	BRACKET,ALTERNATOR R	1								S
(A=E14236)												
14	1	129271-77360	ADJUSTER,ALTERNATOR	1								
15	1	129271-77370	BRACKET,ADJUSTER	1								
16	1	129271-77380	NUT,ADJUSTER	1								
17	1	129271-77450	BRACKET, FEED PUMP	1								
18	1	129271-77460	SUPPORT,FUEL HOSE	1								
19	1	129271-77470	FUEL HOSE,845	1								
21	1	26716-120002	NUT, M12	4								
22	1	22137-080000	WASHER, 8	7								
23	1	22137-120000	WASHER, 12	8								
24	1	26106-080222	BOLT, M8X 22 PLATED	1								
25	1	26106-100222	BOLT, M10X 22 PLATED	1								
26	1	26106-100352	BOLT, M10X 35 PLATED	3								
26-1	1	26106-100402	BOLT, M10X 40 PLATED	3								S
(A=E14236)												
27	1	26116-080752	BOLT, M8X 75 PLATED	1								
28	1	26116-081004	BOLT, M8X100 PLATED	3								
29	1	26116-120452	BOLT, M12X 45 PLATED	2								
30	1	26116-120502	BOLT, M12X 50 PLATED	1								
31	1	26116-120652	BOLT, M12X 65 PLATED	1								
32	1	26716-080002	NUT, M8	3								

Remarks

(1)No.8-1 interchangeable by set.

(2)12V specification : No.4A-1 & 8-1 interchangeable by set.

24V specification : No.34-1 & 8-1 interchangeable by set.



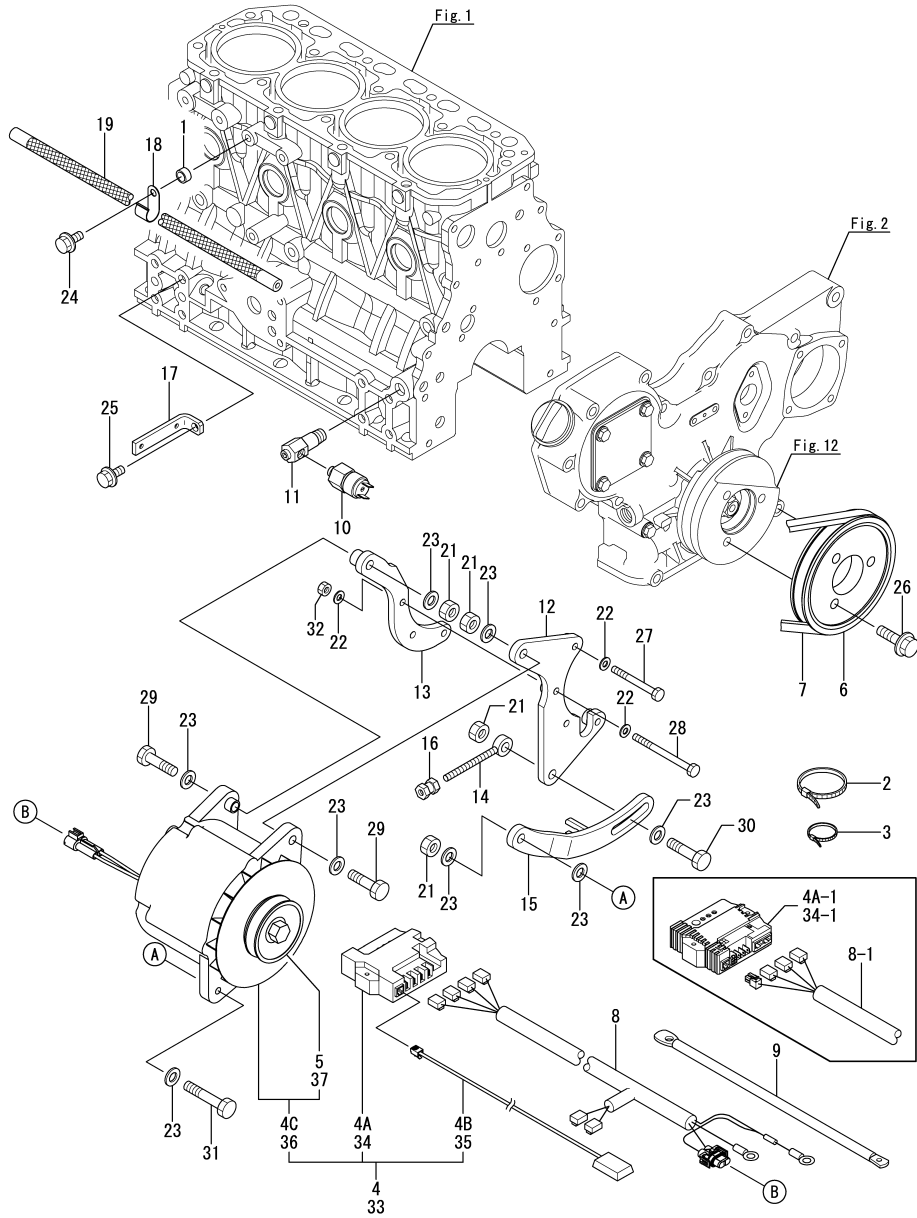

(A)=4JH5E  
(B)=  
(C)=

(D)=  
(E)=  
(F)=

No.	Lev.	Parts No.	Description	Qty						I	R
				(A)	(B)	(C)	(D)	(E)	(F)		
33	1	129271-77230	ALTERNATOR, 24V-75A	1							
33-1	1	129271-77231 (A=*2015.01.)	ALTERNATOR ASSY,24V	1						F	1
34	2	129271-77610 (A=*2011.07.)	REGULATOR ASSY,24V	1							W
34-1	2	129271-77720 (A=*2015.01.)	REGULATOR ASSY,ALPHA	1						F	2
35	2	129271-77620 (A=*2011.07.)	HARNES, BATT SENSING	1							W
36	2	129271-77590 (A=*2011.07.)	ALTERNATOR,24V-75A	1							W
37	3	129271-77240	PULLEY,ALTERNATOR	1							

Remarks

- (1)No.8-1 interchangeable by set.
- (2)12V specification : No.4A-1 & 8-1 interchangeable by set.
- 24V specification : No.34-1 & 8-1 interchangeable by set.



(A)=4JH5E  
(B)=  
(C)=

(D)=  
(E)=  
(F)=

No.	Lev.	Parts No.	Description	Q'ty						I	R
				(A)	(B)	(C)	(D)	(E)	(F)		
2	2	129671-08240	PLATE, ABSORBER	4							
3	2	129671-08250	SPACER, ABSORBER	2							
4	2	129671-08260	RUBBER, MOUNT	2							
5	2	129671-08270	NUT, M16	2							
6	2	129671-08280	BOLT, M16	2							
7	2	129671-08290	BOLT, 10X25	8							
8	2	129671-08230	SUPPORT, MOUNT	2							
9	1	22137-100000	WASHER, 10	3							1
10	1	129671-44300	BOLT, STUD	4							
11	1	129671-67000	BRACKET, ACTUATOR	1							
12	1	129671-77000	ACTUATOR	1							
13	1	129671-77030	BOLT, ACTUATOR	6							
14	1	128990-77510	WASHER	6							
15	1	26366-080002	NUT	4							
16	1	129671-77010	SENSOR, ROTATION	1							
17	1	129671-77020	SLEEVE, SPEED SENSOR	1							
18	1	129671-77930	HARNESS, WIRE	1							
18-1	1	129671-77931	HARNESS, WIRE	1							S 2
(A=E14236)											
19	1	26450-060122	BOLT	1							
20	1	128990-59890	BAND, 200	2							

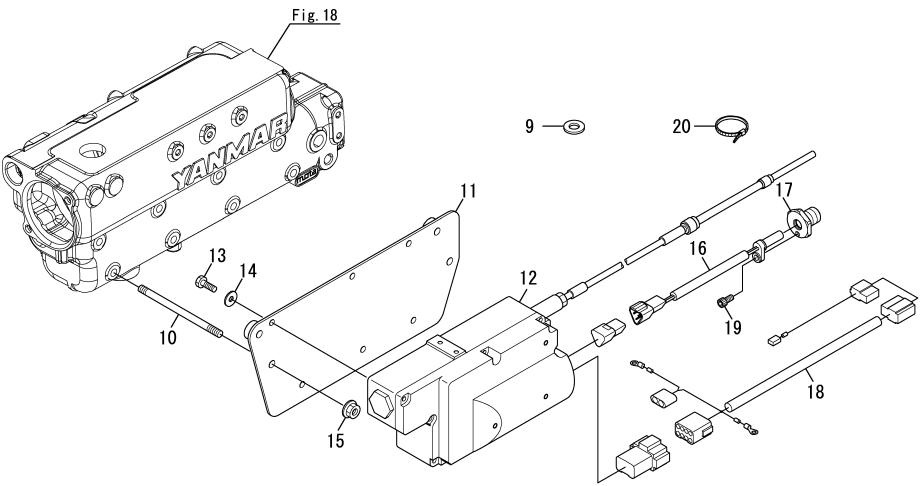
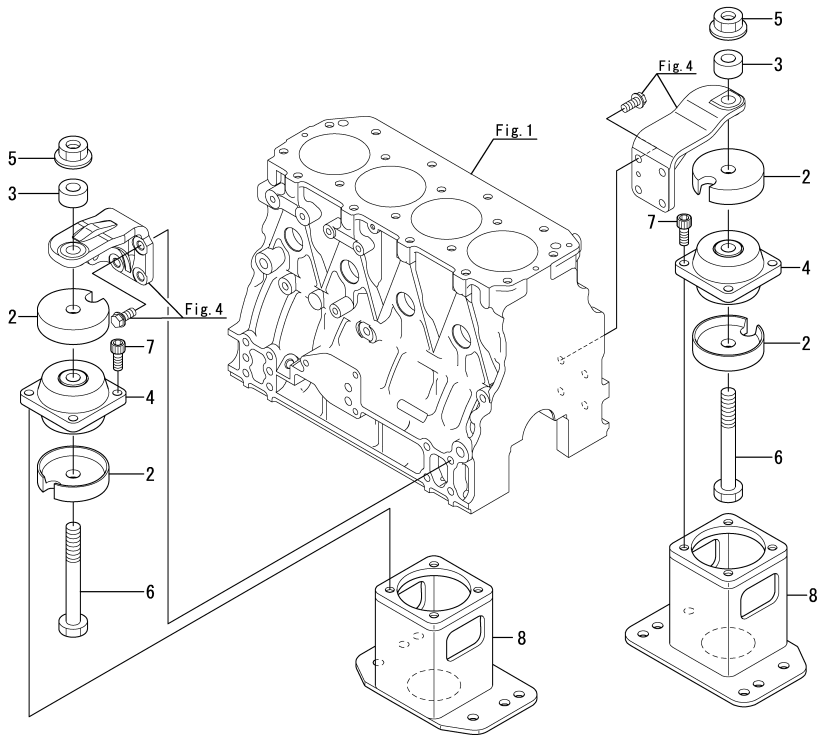

Remarks  
(1) For adjustment.  
(2) Valeo generator specification.



# Parts No. Index

Parts No.	Fig. No.	Ref. No.
104214-83980	33	18
105430-55041	30	8
105583-85900	33	13
114250-53080	26	5
114250-53120	26	10
114250-53130	26	11
114250-53140	26	12
114250-53210	26	13
119129-77250	35	14
119129-77260	35	15
119129-77320	35	3
119129-77890	35	20
119129-77900	35	21
119129-77930	35	19
119225-52102	25	1
119247-77100	38	9
119573-77201	35	1
119575-77071	38	39
119609-32040	2	14
	44	3
119620-01750	3	11
119620-49290	14	24
	18	12
119625-11880	7	19
119660-61901	24	25
119773-42570	16	9
119773-77030	38	47
		48
119773-91650	38	31
119773-91700	38	32
119773-91850	38	26
119802-01561	2	10
119802-03110	8	4
119802-03121	8	5
119802-03130	8	6
119802-03141	8	7
119802-11260	7	25
119802-11270	7	26
119802-11870	7	18
119802-21660	12	9
119802-25071	11	13
119802-25101	11	10
119802-25901	11	17
119802-39450	15	2
119802-51090	23	55
119802-51560	23	59
119802-51590	23	65
119802-51600	23	66
119802-51680	23	68
119802-51690	23	69

Parts No.	Fig. No.	Ref. No.
119802-55810	28	3
119803-21200	12	5
119803-25050	11	9
119803-53400	26	14
119807-61420	24	16
119865-21600	12	16
119934-01800	2	8
120130-11860	7	5
120130-91370	38	18
120149-08431	4	14
		17
120270-54410	7	22
120270-77102	38	23
120322-33050	18	9
120324-55751	29	1
120324-55760	29	2
121023-01551	2	22
121111-21501	12	12
121252-39450	38	17
121370-08351	4	8 -2
121400-11340	7	15
121450-01560	16	24
121550-23200	13	13
121750-59890	8	19
	25	4
		5
	45	3
121750-59910	29	14
121850-21680	12	11
121850-51960	2	15
	44	4
123310-77640	34	25
123325-35140	29	34
123325-35160	29	24
123325-35170	29	25
123325-49421	10	7
	16	18
123672-55760	29	28
123678-55890	29	32
123682-07852	6	4
124060-01050	1	10
124070-77950	38	3
124080-77390	35	10
124080-77520	35	12
124085-35350	14	8 -2
124160-01751	2	11
	8	13
124160-01910	1	5
		15
124160-11360	8	15

Parts No.	Fig. No.	Ref. No.
124160-39140	15	1
124195-77770	34	23
124240-01871	2	12
	16	25
		28
124398-49700	8	18 -1
124413-39100	14	28
124460-11340	7	16
124460-77680	14	30
	18	19
124550-01590	2	18
124616-91370	38	41
124976-34850	1	40
127412-91250	39	9
	40	10
128170-86501	31	21
128377-07150	6	1
128377-07190	6	6
128377-07260	6	2
128377-07350	6	3
128377-07400	6	7
128377-07420	6	8
128377-07450	6	9
128377-07460	6	10
128391-77720	38	29
128397-44500	18	23
128397-44510	18	25
128990-49320	17	31
		32
128990-59131	30	2
128990-59700	30	1
128990-59890	38	33 -2
	49	20
128990-77250	48	18
128990-77400	38	11
128990-77430	9	18
	36	2
	37	2
	38	8
128990-77510	49	14
128990-77550	38	10
128990-77610	36	1
	37	1
	38	7
128990-77910	38	34
129001-01250	1	11
129001-02931	1	25
129004-01190	1	39
129004-03010	8	2
129004-11650	7	30

Parts No.	Fig. No.	Ref. No.
129004-11900	7	20
129004-55612	28	1
129005-11100	7	10
129005-22500	13	3
129005-22900	13	19
129005-22950	13	21
129005-59830	15	3
129006-35100	14	9
		10
129006-44480	14	14
129008-01520	2	9
129008-53000	26	2
129009-51390	23	26
129054-42320	17	6
129065-55760	29	29
129065-55770	29	30
129065-55800	29	31
129100-01580	3	1
		5
	12	2
129100-01640	3	6
129100-11112	7	11
129100-23910	13	16
129120-77502	9	11
129150-01200	1	31
129150-01881	16	22
		26
		29
	44	18
129150-02020	1	7
129150-02450	11	4
129150-02871	1	33
129150-02931	1	28
129150-02941	1	36
129150-03070	8	3
129150-03100	37	23
129150-11230	7	31
129150-11280	7	27
129150-11370	7	17
129150-11750	7	33
129150-11810	7	7
129150-14101	11	7
129150-14200	11	1
129150-14400	11	2
129150-23601	13	14
129150-23611	13	17
129150-25301	11	16
129150-32020	14	46
129150-35042	14	1
	44	15



## Parts No. Index

Parts No.	Fig. No.	Ref. No.
129150-35111	14	12
	44	16
129150-35170	14	13
129150-42059	17	2
129150-42301	17	4
129150-59120	27	1
129150-59131	27	4
		8
129150-77511	9	12
	44	13
129155-51280	24	5
129155-61460	24	18
129156-44760	17	18
129171-85900	33	1
129202-22300	13	7
129255-61410	24	15
129263-42120	17	3
129270-44501	18	24
129270-49400	17	19
129270-59550	28	8
129270-59580	28	10
129270-81110	32	5
129270-81120	32	6
129270-92100	43	1
129270-92600	43	2
129270-92610	43	5
129270-92620	43	6
129270-92630	43	7
129270-92640	43	8
129270-92650	43	3
129270-92690	43	4
129271-01600	2	1
129271-12311	9	14
129271-12810	9	17
129271-21350	37	11
129271-21660	12	28
129271-34880	5	11
129271-42001	17	1
129271-42350	17	38
129271-42501	16	1
129271-42510	16	8
129271-42700	16	21
129271-49110	19	4
		17
		24
	20	4
129271-77220	45	4
129271-77221	45	4 -1
129271-77230	45	33
129271-77231	45	33 -1

Parts No.	Fig. No.	Ref. No.
129271-77240	45	5
		37
129271-77250	45	6
129271-77260	45	7
129271-77270	45	8
129271-77271	45	8 -1
129271-77280	45	9
129271-77290	45	10
129271-77311	37	12
129271-77320	45	11
129271-77330	37	13
129271-77340	45	12
129271-77341	45	12 -1
129271-77350	45	13
129271-77351	45	13 -1
129271-77360	45	14
129271-77370	45	15
129271-77380	45	16
129271-77401	36	3
129271-77410	36	4
	37	3
129271-77411	36	4 -1
129271-77420	36	7
	37	4
129271-77421	36	7 -1
129271-77430	36	8
	37	5
129271-77440	37	6
129271-77450	45	17
129271-77460	45	18
129271-77470	45	19
129271-77501	37	7
129271-77510	37	8
129271-77580	45	4 C
129271-77590	45	36
129271-77600	45	4 A
129271-77610	45	34
129271-77620	45	4 B
		35
129271-77631	48	8
129271-77641	48	9
129271-77651	48	15
129271-77660	48	16
129271-77680	17	24 -1
129271-77720	45	4 A-1
		34 -1
129271-77921	38	13
129271-77931	37	14
129271-77950	24	61
129271-91112	39	1

Parts No.	Fig. No.	Ref. No.
129271-91113	39	1 -1
129271-91120	39	2
129271-91131	39	3
	41	2
129271-91132	39	3 -1
	41	2 -1
129271-91140	39	4
	41	3
129271-91150	39	5
129271-91162	40	1
129271-91163	40	1 -1
129271-91170	40	2
129271-91181	40	3
	42	2
129271-91182	40	3 -1
	42	2 -1
129271-91190	40	4
	42	3
129271-91200	40	5
129271-91210	39	6
	40	6
	41	4
	42	4
129271-91211	39	6 -1
	40	6 -1
	41	4 -1
	42	4 -1
129271-91220	39	7
	40	7
129271-91230	39	8
	40	8
	41	5
	42	5
129271-91240	40	9
	42	6
129271-91250	40	11
	42	7
129271-91260	39	10
	40	12
129271-91301	41	1
129271-91302	41	1 -1
129271-91310	41	6
129271-91320	41	7
129271-91330	41	8
	42	8
129271-91340	41	9
	42	9
129271-91351	42	1
129271-91352	42	1 -1
129271-91360	42	10

Parts No.	Fig. No.	Ref. No.
129271-91370	42	11
129301-34830	45	1
129400-01730	5	5
129407-01340	1	32
	44	2
129407-32000	14	33
129410-03990	8	18
129417-33110	14	8
129417-33111	14	8 -1
129417-35150	14	11
129470-08350	4	7 -2
129470-12120	9	3
129470-12130	9	7
	44	11
129470-13541	10	4
129470-49540	17	25
129470-49801	17	27
129470-49810	17	28
	44	21
129470-67200	31	2
129470-83750	33	22
129470-85900	33	14
129470-86500	31	19
129470-92300	43	9
129470-92310	43	10
129470-92320	43	11
129472-13560	10	5
129472-18090	10	2
		10
	44	14
129473-85900	33	3
129486-01670	3	9
129486-42050	17	16
	44	19
129495-55610	29	26
129495-55620	29	27
129495-59563	28	9
129495-77330	17	34
129508-33010	14	6
129508-33031	14	6 -1
129508-33050	14	7
129508-33060	14	7 -1
129508-35100	14	9 -1
129508-35150	14	11 A
129508-49030	14	20
129550-13110	18	18
	44	22
129550-42350	17	17
129550-59120	27	5
129570-77960	38	24



## Parts No. Index

Parts No.	Fig. No.	Ref. No.
129574-77710	38	27
129574-77720	38	28
129574-77740	38	30
129574-77980	38	25
129601-11241	7	24
129601-11251	7	28
129601-11310	8	10
	44	8
129601-11350	8	1
129601-51250	23	119
129602-11700	7	1
129604-21000	12	1
129608-77010	34	1
129608-77110	34	4
129642-61060	24	62
129657-49020	14	15
129657-49180	14	17
129670-01600	3	2
129670-01700	5	1
129670-03090	8	17
129670-03091	8	17 -1
129670-07230	18	13
129670-08211	4	3
129670-08220	4	4
129670-08231	4	1
129670-08241	4	2
129670-08340	4	8
129670-08341	4	8 -1
129670-08350	4	7
129670-08351	4	7 -1
129670-11960	8	20
129670-12360	9	15
129670-12410	9	16
129670-13561	10	1
129670-13600	18	17
	32	14
129670-21591	12	13
129670-22020	13	1
129670-34800	5	10
129670-35090	14	2
129670-39600	38	19
129670-39990	14	29
129670-42520	16	6
129670-42531	16	3
129670-42540	16	5
129670-42550	16	7
129670-42560	16	11
129670-42570	16	15
129670-42580	16	17
129670-44150	18	6

Parts No.	Fig. No.	Ref. No.
129670-44430	18	8
129670-44450	18	11
129670-44460	18	7
129670-44570	18	26
129670-44910	18	1
129670-44911	18	1 -1
129670-49020	19	1
129670-49090	19	8
129670-49150	19	15
129670-49220	19	9
129670-49230	19	12
129670-49240	19	13
129670-49250	19	26
129670-49260	19	19
129670-49270	19	20
		27
129670-49280	10	6
129670-49360	19	3
129670-49390	17	33
129670-49410	19	10
129670-49500	10	9
	19	5
		11
		16
		21
		28
	20	3
	21	13
129670-51600	23	60
129670-55010	25	2
129670-55670	28	2
129670-55750	29	23
129670-55810	29	22
129670-59110	25	3
129670-59140	28	12
129670-59150	28	6
129670-59710	27	10
129670-59720	27	11
129670-59730	27	12
129670-59740	27	13
129670-67110	31	16
129670-67120	31	1
129670-77030	34	27
129670-77350	35	23
	48	5
129670-77370	35	24
	48	6
129670-77380	35	25
	48	7
129670-77800	32	1

Parts No.	Fig. No.	Ref. No.
129670-77810	32	2
129670-77820	32	3
129670-77830	32	4
129670-77920	38	1
129670-77921	38	1 -1
129670-77940	38	2
129670-77980	38	40
129670-81040	32	9
129670-81050	32	10
129670-81060	32	11
129670-81100	32	12
129670-81110	32	13
129670-81200	32	7
129670-81210	32	8
129670-81850	12	25
129670-85900	33	2
129671-08230	49	8
129671-08240	49	2
129671-08250	4	16
	49	3
129671-08260	49	4
129671-08270	49	5
129671-08280	49	6
129671-08290	49	7
129671-44300	49	10
129671-49110	19	18
		25
129671-49120	19	2
129671-49210	20	1
129671-49220	20	2
129671-49990	38	37
129671-67000	49	11
129671-77000	49	12
129671-77010	49	16
129671-77020	49	17
129671-77030	49	13
129671-77930	49	18
129671-77931	49	18 -1
129671-92110	43	13
129671-92120	43	14
129671-92130	43	15
129673-44090	18	4
129673-44110	18	3 A
129673-44131	18	5
129673-44150	18	3 B
129673-81250	12	23
129673-85100	33	15
129675-77571	38	49
129677-07450	38	45
129677-07460	38	46

Parts No.	Fig. No.	Ref. No.
129693-44300	18	28
129698-12100	9	1
129698-77020	34	2
129698-77101	34	3
129698-77120	34	5
129698-77130	34	7
129698-77140	34	6
129698-77150	34	8
129698-77161	34	9
129698-77170	34	10
129698-77180	34	17
129698-77190	34	18
129698-77200	34	19
129698-77210	34	20
129698-77220	34	21
129698-77230	34	22
129698-77240	34	15
129698-77250	34	16
129698-77260	34	11
129698-77270	34	13
129698-77280	34	14
129795-01780	3	8
129795-01950	2	13
129795-02412	1	14
129795-11120	7	12
129795-11180	7	13
129795-21661	12	10
129795-48800	21	1
129795-48801	21	16
129795-48810	21	17
129795-48820	21	18
129795-48830	21	19
129795-48840	21	20
129795-48850	21	21
129795-48860	21	22
129795-48870	21	23
129795-48880	21	24
129795-48890	21	25
129795-48900	21	26
129795-49551	17	26
	44	20
129900-07900	7	37
129916-49740	17	7
129916-59020	23	115
129928-51340	23	48
129C26-01890	16	26 -1
		29 -1
	44	18 -1
138603-59380	30	4
158552-51151	11	18



## Parts No. Index

Parts No.	Fig. No.	Ref. No.
158552-51571	23	49
		50
158552-51580	23	62
158552-51600	23	64
158552-51670	23	113
158552-51781	23	11
158552-52100	23	84
158552-52310	23	86
158552-52400	23	42
158552-52500	23	85
158552-61441	24	17
158552-61900	24	47
158553-51630	23	72
158553-51660	23	76
158553-51670	23	67
158553-51680	23	77
158553-51741	23	9
158553-51770	23	38
158553-61050	24	2
158553-61070	24	3
158557-51570	23	61
158563-51281	23	44
		45
158563-51330	23	47
158600-51270	23	46
158601-51550	23	57
158601-51650	23	75
158601-51770	23	10
158601-51790	23	12
164100-21100	46	2
	47	3
164100-21200	47	18
164100-22720	38	27 -1
164100-22730	38	28 -1
164100-22740	38	30 -1
164100-22830	38	29 -1
164100-23700	38	57
164100-23900	38	43
		43 -1
164100-23910	38	44
164100-30100	46	1
164100-30101	46	1 -1
164100-30102	46	1 -2
164100-30200	47	1
164100-30210	47	17
164100-31100	46	3
	47	4
164100-31101	46	3 -1
	47	4 -1
164100-31150	46	4

Parts No.	Fig. No.	Ref. No.
164100-31150	47	5
164100-31900	46	5
	47	6
164100-36100	46	6
	47	7
164100-39100	46	7
164100-39120	46	8
	47	9
164100-39130	46	9
	47	10
164100-39131	46	9 -1
	47	10 -1
164100-39150	46	10
	47	11
164100-39180	46	11
	47	12
		19
164100-39190	46	12
	47	13
		20
164100-39200	47	21
164100-39230	47	22
164100-53100	46	13
	47	14
164100-53101	46	13 -1
	47	14 -1
164100-53102	46	13 -2
	47	14 -2
164100-53150	46	14
	47	15
164100-53200	47	23
164100-53210	47	24
164100-53250	47	25
164100-53900	46	15
	47	16
164100-53920	47	26
171008-03990	14	19
		21
171051-01921	1	6
177070-03520	12	21
177073-02431	6	11
177088-02430	6	5
177090-03500	12	17
194250-51660	38	33
		38
	45	2
196420-02790	50	1
196440-02380	4	10
196440-02390	4	11
196440-04310	12	19

Parts No.	Fig. No.	Ref. No.
196630-12980	6	12
22137-080000	35	26
	37	15
		16
		16
	38	4
	45	22
	48	10
22137-100000	12	30
	35	27
	49	9
22137-120000	45	23
22137-160000	4	18
22157-080000	36	5
	37	9
	38	12
22190-080002	2	19
		27
	9	8
	15	4
		6
	44	12
22190-100002	15	7
	44	17
22190-120002	23	13
		87
		88
	24	29
	44	23
22190-140002	5	14
	29	15
	44	7
22190-180002	23	14
22217-050000	31	7
	48	1
22217-080000	5	15
	12	26
	31	8
	38	5
		50
		51
	48	2
22217-100000	5	16
22217-120000	4	12
22217-140000	11	19
	23	74
22242-000100	31	6
22252-000260	13	8
22312-050140	23	78
22351-030010	12	8
22351-050010	23	63

Parts No.	Fig. No.	Ref. No.
22351-060012	7	21
22414-250150	31	9
22512-070140	11	8
	12	6
22724-800380	34	26
22857-500100	8	11
		12
23000-013000	25	6
	28	11
	29	16
23000-016000	28	7
23000-022000	19	14
23000-048000	9	20
23000-060000	9	19
23010-013000	18	27
23010-014000	30	5
23061-070300	14	31
	18	20
23072-101000	21	12
23080-015000	14	18
		23
23414-080000	31	10
	44	24
23414-100000	9	4
	44	10
23414-140000	5	3
23414-170000	18	15
23851-080000	5	17
23857-030000	15	5
23857-060000	23	54
23857-080000	29	17
23875-010000	38	20
23875-030000	17	21
	38	42
23887-100002	9	5
23887-120002	23	15
	24	31
23887-140002	5	4
23887-180002	38	22
23894-030002	18	16
24311-000060	21	11
24311-000070	23	43
24311-000080	21	27
24311-000120	8	16
	29	35
	44	9
24311-000320	2	17
	8	14
	44	5
24321-000750	21	28



## Parts No. Index

Parts No.	Fig. No.	Ref. No.
24341-000240	2	23
	44	6
24356-010180	23	41
24356-010200	23	40
		70
24358-240310	17	5
24372-000150	23	71
25132-003800	37	17
25152-004300	17	24
26013-080652	17	35
26106-060102	17	22
	23	39
	24	33
	38	14
26106-060122	17	39
	25	7
26106-060142	24	48
		49
26106-060162	2	24
	38	15
26106-060202	17	8
	24	50
26106-080122	9	9
	19	6
		22
		29
	31	15
	38	52
26106-080142	11	15
26106-080162	2	20
		25
	5	9
		18
	7	34
	9	21
	12	18
		22
		27
	16	30
	19	7
	23	117
	38	6
26106-080202	9	10
	12	20
	14	27
	16	23
	23	118
	32	15
	38	16
26106-080222	45	24

Parts No.	Fig. No.	Ref. No.
26106-080252	5	7
	7	35
	12	24
	16	27
	17	29
	28	4
	31	11
	35	28
	37	19
26106-080302	2	28
	29	18
26106-080352	3	10
	7	23
	9	13
	14	32
	17	30
26106-080402	11	14
26106-080452	5	8
26106-080502	7	36
26106-080552	2	26
	17	23
		36
26106-080652	48	11
26106-080702	25	8
26106-080852	2	16
26106-081002	18	21
26106-100162	5	19
26106-100202	12	29
26106-100222	4	5
	45	25
26106-100252	28	5
26106-100302	29	19
	37	18
		20
26106-100322	33	9
		16
		19
		25
26106-100352	45	26
26106-100402	45	26 -1
26116-060162	17	9
26116-080302	21	14
26116-080752	45	27
26116-080804	48	12
26116-080904	37	21
26116-081004	45	28
26116-120252	4	6
26116-120302	34	24
26116-120452	45	29
26116-120502	45	30

Parts No.	Fig. No.	Ref. No.
26116-120652	45	31
26206-100252	3	3
26206-100302	3	4
26216-080202	38	53
26226-080182	7	29
26306-080002	2	21
	5	20
	16	20
	18	22
	19	23
		30
	25	9
	29	20
	31	12
	32	16
	36	6
	37	10
		22
26306-100002	29	21
26366-060002	15	8
26366-080002	36	9
		38
		54
		55
		56
	48	13
	49	15
26450-060122	49	19
26450-060252	14	47
26450-080162	18	14
26450-080302	33	20
26450-080452	23	34
26450-120402	33	24
26476-060142	9	6
26557-050122	31	13
26577-060142	17	10
26664-080002	21	7
26703-080002	10	3
		8
		21
	15	15
26706-100002	33	10
		17
		21
		26
26716-050002	31	14
	48	3
26716-080002	45	32
	48	14
26716-120002	4	13
	43	12
	45	21

Parts No.	Fig. No.	Ref. No.
26716-160002	48	17
26756-060002	24	34
26756-080002	33	11
	34	28
	48	4
26776-140002	11	20
	23	79
27241-120000	1	12
27241-300000	1	13
27241-400000	7	9
27310-080001	7	14
29622-250001	38	33 -1
	45	2 -1
41650-502320	29	33
41710-000380	31	18
41710-000410	31	17
41730-000681	31	20
43530-500570	19	31
43662-025031	19	32
48110-028071	33	4
48110-030061	33	6
48110-032065	33	7
48110-032411	33	12
48110-032502	33	5
48110-034071	33	8
729271-53100	26	1
729402-14580	11	3
729402-23100	13	9
729602-01560	1	1
729670-51330	23	1
729670-92600	44	1
796440-08630	4	9
83213-003012	30	7
977780-01211	22	1
977780-03000	22	9
X00190001	16	13
X00370017	16	16
X00371040	16	19
X0044021509	22	7
X0146531	16	4
X02230015	16	12
X02233001	16	14
X0300120414	29	8
X0311121522	29	6
X0313080922	29	12
X0314080110	29	10
X0318101004	22	2
X03431483	16	10
X0580121073	29	7
X0582810173	29	5

# Parts No. Index

Parts No.	Fig. No.	Ref. No.
X0588080273	29	11
X0600160122	29	9
X0993071171	29	13
X158606410X	22	3
X179100022X	22	5
X179100100X	22	6
X199906101X	22	8
X2114535200	34	12
X2740134002	29	3
X6303BM0000	35	18
X8636015001	22	4
XL150M14041	35	17
XL155G1330	35	8
XL180120000	35	4
XL1808320	35	13
XL180G13012	35	6
XL180G43150	35	7
XL180G61000	35	2
XL180G63006	35	5
XL180G85001	35	22
XL225431800	35	11
XL225G1325	35	9
XL235340110	35	16
XTST25S001	21	2
XTST25S002	21	3
XTST25S003	21	4
XTST25S004	21	5
XTST25S005	21	6
XTST25S007	21	8
XTST25S008	21	9
XTST25S009	21	10

Parts No.	Fig. No.	Ref. No.
-----------	----------	----------

Parts No.	Fig. No.	Ref. No.
-----------	----------	----------

Parts No.	Fig. No.	Ref. No.
-----------	----------	----------