

OCR10-M44901EN

P R E F A C E

1. This Parts Catalog carries all parts incorporated in YANMAR Model 3TNE78A-SA, 3TNE78A-G1A, 3TNE78A-G2A & 3TNE78AC-G1A.

2. Parts catalog history

| | Parts catalog No. | Published | Note |
|-------------|-------------------|------------|--------------------|
| 1st edition | 000Y00R4490 | May., 1995 | Disuse old edition |
| 1st revised | 000Y00R4491 | Jul., 2002 | |

3. Model name

| Column | Model name | Manufactured | E/# |
|--------|--------------|--------------|--------|
| (A) | 3TNE78A-SA | 1996/4~ | 10184~ |
| (B) | 3TNE78A-G1A | 1996/7~ | 10615~ |
| (C) | 3TNE78A-G2A | 1996/4~ | 10201~ |
| (D) | 3TNE78AC-G1A | 1996/10~ | 00973~ |

4. Each illustration corresponds to the parts list on the following page.

5. When ordering parts, clearly write down the engine model and serial number, as well as the name and number of each part in your order sheet. This will help insure reliable delivery of the parts you have ordered.

Directions for the Parts Catalog.

1. This Parts Catalog shows both standard and optional parts.
2. Parts may change without prior notice.
3. The following is an example of the Parts Catalog format.

| REF. | LEV. | PARTS NO. | DESCRIPTION | Q'TY | | | | | | I | R |
|------|------|--|---------------------|------|-----|-----|-----|-----|-----|---|---|
| | | | | (A) | (B) | (C) | (D) | (E) | (F) | | |
| 1 | 1 | 729595-51390 | FUEL INJECTION PUMP | 1 | 1 | 1 | 1 | 1 | | | 1 |
| 1-1 | 1 | 729595-51391 | FUEL INJECTION PUMP | 1 | 1 | 1 | 1 | 1 | | N | 1 |
| | | (A=E00185) (B=E00200) | | | | | | | | | |
| 3 | 2 | 26022-060162 | SCREW M 6X 16 | 9 | 9 | 9 | 9 | 9 | | | |
| 3-1 | 2 | 26022-060162 | SCREW M 6X 16 | 4 | 4 | 4 | 4 | 4 | | K | |
| | | (A=E00156) (B=E00156) (C=E00156) (D=E00156) (E=E00156) | | | | | | | | | |
| 4 | 2 | 129470-51040 | CAMSHAFT | 1 | 1 | 1 | 1 | 1 | | | |
| 5 | 2 | 122710-51050 | BEARING, ROLLER | 2 | 2 | 2 | 2 | 2 | | | |
| 6 | 2 | 129470-51060 | RETAINER | 1 | 1 | 1 | 1 | 1 | | | |

| |
|---|
| Remarks |
| (1) BOOST COMPEMSATOR TYPE. OPTIONAL PART, TO E00155,(4JH-DT, 4JH-DTZ |

① Ref. No.

The Ref. No. listed may not be in accordance with the illustration Ref. No.

(Ex.) Illustration No. 1 List Ref No. 1 (Before change) → 1-1 (After change)

For interchangeable symbols N, R and K, illustrations for new parts may be abbreviated.

② Lev. (Level)

Level indication

The numbers below indicate the level of relativity towards the main part.

1 ---- Main parts (Assembly parts)

2 ---- Sub component included in " 1 ".

3 ---- Sub component included in " 2 ".

Note) Parts that are not for sale are partially illustrated but not listed.

③ Interchangeability Symbol

When a part change takes place, one of the following interchangeability symbols is indicated beside the part.

| Symbol | Interchangeability | Contents note |
|--------|---|--|
| N | Old $\begin{matrix} \leftarrow \text{Yes} \\ \text{No} \rightarrow \end{matrix}$ New | New Part is interchangeable for Old Part but Old Part is not interchangeable for New Part. |
| Q | Old $\begin{matrix} \leftarrow \text{No} \\ \text{Yes} \rightarrow \end{matrix}$ New | New Part is not interchangeable for Old Part but Old Part is interchangeable for New Part. |
| R | Old $\begin{matrix} \leftarrow \text{Yes} \\ \text{Yes} \rightarrow \end{matrix}$ New | New/ Old Parts are both interchangeable. |
| S | Old $\begin{matrix} \leftarrow \text{No} \\ \text{No} \rightarrow \end{matrix}$ New | New/ Old Parts are both not interchangeable. |
| W | | Part newly added. |
| Z | | Part discontinued. |
| F | | Not interchangeable by a single part but interchangeable together with related parts. |
| K | | Changes only for used parts quantities. |

④ Effective Machine No.

When a part changes, the effective Machine No. will be indicated in the (A)-(F) column.

| Product Symbol | Product No. | Product Symbol | Product No. |
|----------------|---------------------------|----------------|-----------------------------------|
| C | Clutch No. Compressor No. | F | Machine No. (Agricultural Equip.) |
| D | Drive No. | M | Machine No. |
| E | Engine No. | | |

Note 1) A date may follow the symbol. (Ex.) 1996.01

Note 2) " XXXXX " and " ZZZZZ " are for parts that could not be predicted or for engine models that could not be identified.

Note 3) (A=E00185) is the E (Engine Serial Number) for the column (A) model (in this case 4JH-DT) after the parts design change.

⑤ Remarks

Figures or alphabets (symbols) are entered in the remarks column.

The comments (remarks) on parts that are indicated at the bottom of the illustration are the same symbols as those stated above.

Fig. No. Fig. Name

3TNE78A(C)-SA,G1A,G2A

1. CYLINDER BLOCK
2. GEAR HOUSING
3. FLYWHEEL HOUSING & OIL SUMP
4. CYLINDER HEAD & BONNET (1)
5. CYLINDER HEAD & BONNET (2)
6. SUCTION MANIFOLD & AIR CLEANER
7. EXHAUST MANIFOLD & SILENCER
8. CAMSHAFT & DRIVING GEAR
9. CRANKSHAFT & PISTON
10. LUB.OIL SYSTEM
11. COOLING WATER SYSTEM
12. RADIATOR
13. FUEL INJECTION PUMP
14. GOVERNOR
15. FUEL INJECTION VALVE
16. FUEL FILTER
17. ENGINE CONTROL DEVICE
18. STARTING MOTOR
19. STARTING MOTOR(COLD DISTRICT)
20. GENERATOR
21. PANEL
22. GASKET SET

Fig. No. Fig. Name



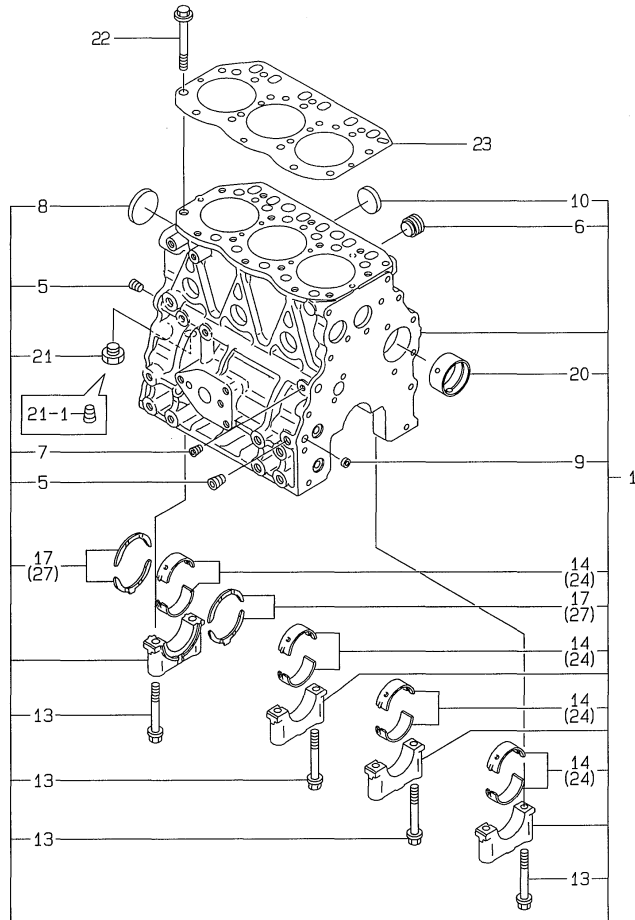

| No. | Lev. | Parts No. | Description | Q'ty | | | | | | I | R |
|------|------|---|----------------------|------|-----|-----|-----|-----|-----|---|---|
| | | | | (A) | (B) | (C) | (D) | (E) | (F) | | |
| 1 | 1 | 719822-01560 | BLOCK ASSY, CYLINDER | 1 | 1 | 1 | 1 | | | | |
| 5 | 2 | 124160-01910 | PLUG, PT1/4 | 2 | 2 | 2 | 2 | | | | |
| 6 | 2 | 171051-01921 | PLUG, NPTF1 | 1 | 1 | 1 | 1 | | | | |
| 7 | 2 | 23871-010000 | PLUG, R01 | 1 | 1 | 1 | 1 | | | | |
| 7-1 | 2 | 23876-010000 | PLUG, R01 | 1 | 1 | 1 | 1 | | | N | |
| | | (A=E14548) (B=E14653) (C=E14549) (D=E01873) | | | | | | | | | |
| 8 | 2 | 27231-500000 | PLUG 50 | 1 | 1 | 1 | 1 | | | | |
| 8-1 | 2 | 129001-01250 | PLUG, 50 | 1 | 1 | 1 | 1 | | | N | |
| | | (A=E14548) (B=E14653) (C=E14549) (D=E01873) | | | | | | | | | |
| 9 | 2 | 27241-120000 | PLUG, 12 | 2 | 2 | 2 | 2 | | | | |
| 10 | 2 | 27241-300000 | PLUG 30 | 6 | 6 | 6 | 6 | | | | |
| 13 | 2 | 119620-02020 | BOLT, METAL CAP | 8 | 8 | 8 | 8 | | | | |
| 14 | 2 | 119810-02800 | BEARING, MAIN | 4 | 4 | 4 | 4 | | | | |
| 17 | 2 | 119810-02930 | BEARING, THRUST | 1 | 1 | 1 | 1 | | | | |
| 20 | 2 | 129795-02411 | BUSH, CAMSHAFT | 1 | 1 | 1 | 1 | | | | |
| 21 | 2 | 23887-120002 | PLUG, 12 | 1 | 1 | 1 | 1 | | | | |
| 21-1 | 2 | 124160-01910 | PLUG, PT1/4 | 1 | 1 | 1 | 1 | | | S | |
| | | (A=E14548) (B=E14653) (C=E14549) (D=E01873) | | | | | | | | | |
| 22 | 1 | 119810-01200 | BOLT, HEAD | 14 | 14 | 14 | 14 | | | | |
| 23 | 1 | 119818-01330 | GASKET, HEAD | 1 | 1 | 1 | 1 | | | | |
| 24 | 1 | 119810-02870 | BEARING, 0.25 US | 4 | 4 | 4 | 4 | | | 1 | |
| 27 | 1 | 119810-02940 | BEARING, THRUST 0.25 | 2 | 2 | 2 | 2 | | | 2 | |

Remarks
(1) UNDER-SIZE(U.S=0.25)PART.
(2) OVER-SIZE(O.S=0.25)PART.

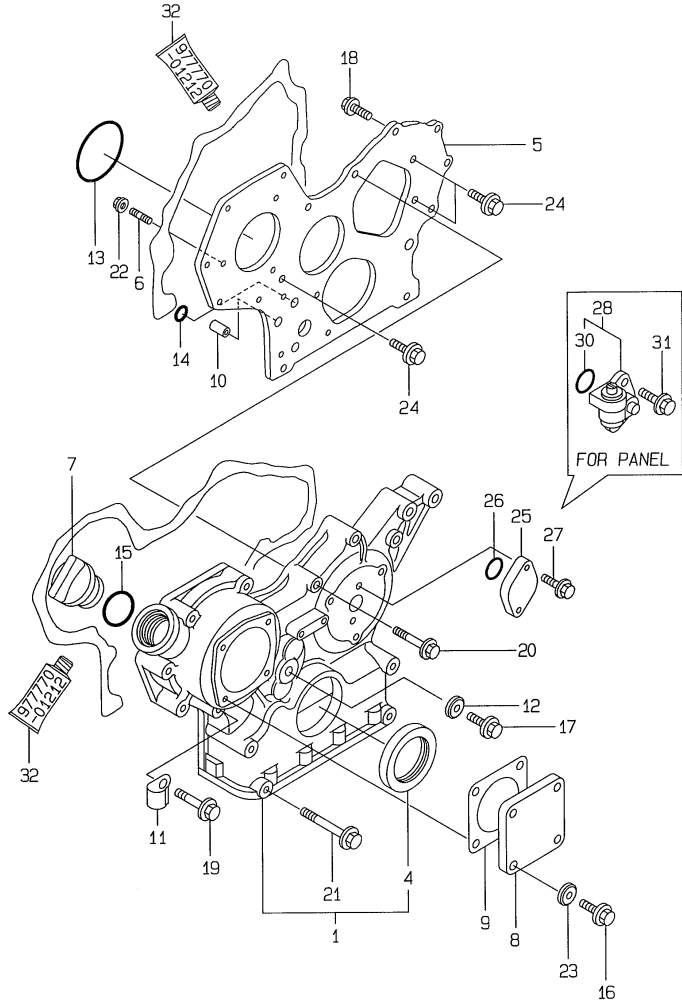

| No. | Lev. | Parts No. | Description | Q'ty | | | | | | I | R |
|------|------|--------------|---------------------|------------|------------|-----|-----|-----|-----|---|-----|
| | | | | (A) | (B) | (C) | (D) | (E) | (F) | | |
| 1 | 1 | 719810-01500 | CASE ASSY, GEAR | 1 | 1 | 1 | 1 | | | | |
| 4 | 2 | 129795-01800 | SEAL, OIL | 1 | 1 | 1 | 1 | | | | |
| 5 | 1 | 129400-01520 | FLANGE, GEAR CASE | 1 | 1 | 1 | 1 | | | | |
| 6 | 1 | 121450-01560 | STUD, M8X22 | 3 | 3 | 3 | 3 | | | | |
| 7 | 1 | 124160-01751 | COVER, FILLER | 1 | 1 | 1 | 1 | | | | |
| 8 | 1 | 124240-01871 | COVER | 1 | 1 | 1 | 1 | | | | |
| 9 | 1 | 124240-01883 | GASKET | 1 | 1 | 1 | 1 | | | | |
| 10 | 1 | 129795-01950 | PIPE, KNOCK L=18 | 2 | 2 | 2 | 2 | | | | |
| 11 | 1 | 129150-03100 | RETAINER, PIPE | 1 | 1 | 1 | 1 | | | | |
| 12 | 1 | 22190-080002 | WASHER, SEAL 6 | 1 | 1 | 1 | 1 | | | | |
| 13 | 1 | 121850-51960 | O-RING | 1 | 1 | 1 | 1 | | | | |
| 14 | 1 | 24311-000160 | O-RING, 1AP16.0 | 2 | 2 | 2 | 2 | | | | |
| 15 | 1 | 24311-000320 | O-RING, 1AP32.0 | 1 | 1 | 1 | 1 | | | | |
| 16 | 1 | 26106-080122 | BOLT, M8X 12 PLATED | 4 | 4 | 4 | 4 | | | | |
| 17 | 1 | 26106-080162 | BOLT, M8X 16 PLATED | 1 | 1 | 1 | 1 | | | | |
| 18 | 1 | 26106-080202 | BOLT, M8X 20 PLATED | 2 | 2 | 2 | 2 | | | | |
| 19 | 1 | 26106-080452 | BOLT, M8X 45 PLATED | 6 | 6 | 6 | 6 | | | | |
| 20 | 1 | 26106-080552 | BOLT, M8X 55 PLATED | 3 | 3 | 3 | 3 | | | | |
| 21 | 1 | 26106-080852 | BOLT, M8X 85 PLATED | 4 | 4 | 4 | 4 | | | | |
| 21-1 | 1 | 129001-91840 | BOLT, M8X85 | 4 | 4 | 4 | 4 | | | | R |
| | | (A=E14685) | (B=E14731) | (C=E14686) | (D=E01891) | | | | | | |
| 22 | 1 | 26366-080002 | NUT, M8 | 3 | 3 | 3 | 3 | | | | |
| 22-1 | 1 | 26306-080002 | NUT, M8 | 3 | 3 | 3 | 3 | | | | N |
| | | (A=EXXX) | (B=EXXX) | (C=EXXX) | (D=EXXX) | | | | | | |
| 23 | 1 | 22190-080002 | WASHER, SEAL 6 | 4 | 4 | 4 | 4 | | | | |
| 24 | 1 | 26106-080162 | BOLT, M8X 16 PLATED | 3 | 3 | 3 | 3 | | | | |
| 25 | 1 | 121023-01550 | COVER | 1 | 1 | 1 | 1 | | | | |
| 26 | 1 | 24341-000240 | O-RING, 1AS24.0 | 1 | 1 | 1 | 1 | | | | |
| 27 | 1 | 26106-060162 | BOLT, M6X 16 PLATED | 2 | 2 | 2 | 2 | | | | |
| 28 | 1 | 129150-91400 | GEAR | 1 | 1 | 1 | 1 | | | | 1 |
| 30 | 2 | 24341-000240 | O-RING, 1AS24.0 | 1 | 1 | 1 | 1 | | | | 1 |
| 31 | 1 | 26106-060162 | BOLT, M6X 16 PLATED | 2 | 2 | 2 | 2 | | | | 1 |
| 32 | 1 | 977770-01212 | GASKET, LIQUID | 1 | 1 | 1 | 1 | | | | W 2 |
| | | (A=EXXX) | (B=EXXX) | (C=EXXX) | | | | | | | |

Remarks
(1) FOR PANEL.
(2) OPTIONAL PART.

(A)=3TNE78A-SA
(B)=3TNE78A-G1A
(C)=3TNE78A-G2A

(D)=3TNE78AC-G1A
(E)=
(F)=

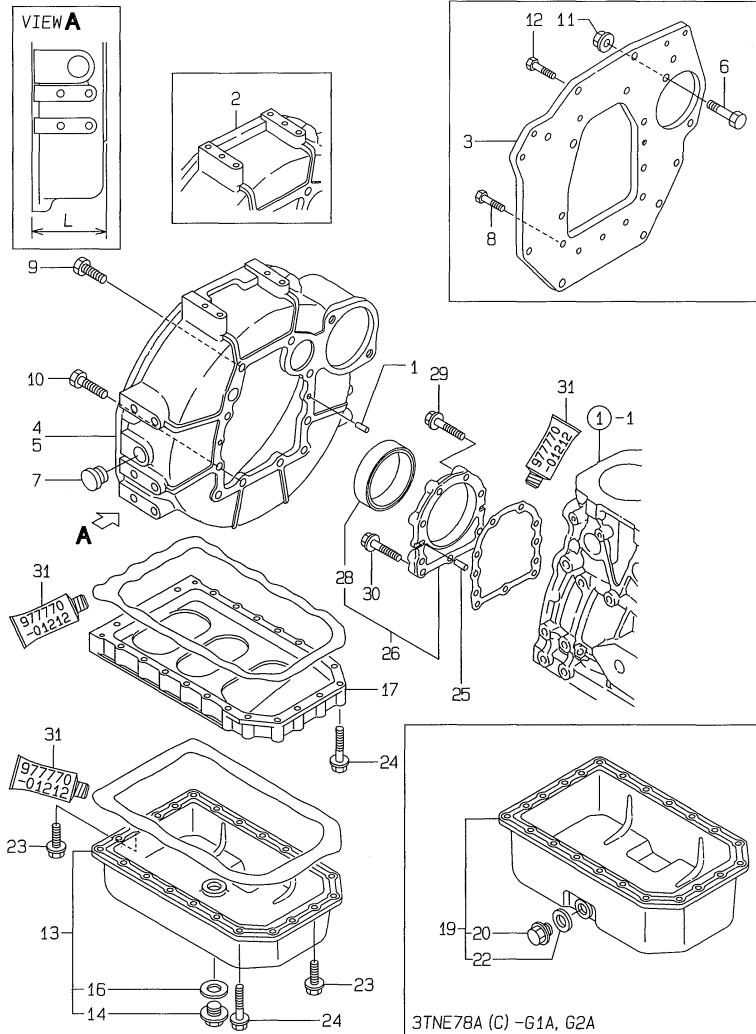

| No. | Lev. | Parts No. | Description | Q'ty | | | | | | I | R |
|------|------|---|---------------------------------|------|-----|-----|-----|-----|-----|-----|---|
| | | | | (A) | (B) | (C) | (D) | (E) | (F) | | |
| 1 | 1 | 129100-01580 | PIN, M8X16 | 2 | 2 | 2 | 2 | | | | |
| 2 | 1 | 119888-01600 | HOUSING, FLYWHEEL | 1 | | 1 | | | | | |
| 3 | 1 | 129129-01600 | FLANGE, MOUNTING | 1 | | 1 | | | | | |
| 4 | 1 | 171301-01600 | HOUSING, FLYWHEEL | 1 | | 1 | | | | 1 | |
| 4-1 | 1 | 129612-01600 (A=E10463) | HOUSING, FLYWHEEL (C=E12582) | 1 | | 1 | | | | N 1 | |
| 5 | 1 | 171420-01600 | HOUSING, FLYWHEEL | 1 | 1 | 1 | 1 | | | 2 | |
| 6 | 1 | 121476-01620 | BOLT | 2 | | 2 | | | | | |
| 7 | 1 | 119620-01750 | CAP | 1 | 1 | 1 | 1 | | | | |
| 8 | 1 | 26206-100202 | BOLT, M10X 20 PLATED | 6 | | 6 | | | | | |
| 9 | 1 | 26206-100252 | BOLT, M10X 25 PLATED | 6 | 6 | 6 | 6 | | | | |
| 10 | 1 | 26206-100302 | BOLT, M10X 30 PLATED | 4 | 4 | 4 | 4 | | | | |
| 11 | 1 | 26367-120002 | NUT, M12 | 2 | | 2 | | | | | |
| 12 | 1 | 26206-100252 | BOLT, M10X 25 PLATED | 4 | | 4 | | | | | |
| 13 | 1 | 119810-01790 | SUMP ASSY, OIL | 1 | | | | | | | |
| 14 | 2 | 119640-01640 | PLUG, DRAIN M22 | 1 | | | | | | | |
| 16 | 2 | 22190-220002 | WASHER, SEAL 22 | 1 | | | | | | | |
| 17 | 1 | 119810-01730 | SPACER, OIL SUMP | 1 | 1 | 1 | 1 | | | | |
| 19 | 1 | 119810-01770 | SUMP ASSY, OIL | | 1 | 1 | 1 | | | | |
| 20 | 2 | 119640-01640 | PLUG, DRAIN M22 | | 1 | 1 | 1 | | | | |
| 22 | 2 | 22190-220002 | WASHER, SEAL 22 | | 1 | 1 | 1 | | | | |
| 23 | 1 | 26106-080162 | BOLT, M8X 16 PLATED | 6 | 6 | 6 | 6 | | | | |
| 24 | 1 | 26106-080452 | BOLT, M8X 45 PLATED | 22 | 22 | 22 | 22 | | | | |
| 25 | 1 | 129100-01580 | PIN, M8X16 | 2 | 2 | 2 | 2 | | | | |
| 26 | 1 | 719810-01650 | CASE ASSY, OIL SEAL | 1 | 1 | 1 | 1 | | | | |
| 28 | 2 | 119810-01780 | SEAL, 769310 | 1 | 1 | 1 | 1 | | | | |
| 29 | 1 | 26106-080302 | BOLT, M8X 30 PLATED | 6 | 6 | 6 | 6 | | | | |
| 29-1 | 1 | 129486-01670 (A=E10463) (B=E10615) (C=E12582) (D=E00973) | BOLT, M8X30 | 6 | 6 | 6 | 6 | | | R | |
| 30 | 1 | 26106-080352 | BOLT, M8X 35 PLATED | 3 | 3 | 3 | 3 | | | | |
| 31 | 1 | 977770-01212 (A=E10463) (B=E10615) (C=E12582) (D=E00973) | GASKET, LIQUID | 1 | 1 | 1 | 1 | | | W 3 | |
| | | (A=E10463) (B=E10615) (C=E12582) (D=E00973) | | | | | | | | | |

Remarks

- (1) L= 80M/M.
- (2) L= 105M/M.
- (3) OPTIONAL PART.

(A)=3TNE78A-SA
(B)=3TNE78A-G1A
(C)=3TNE78A-G2A

(D)=3TNE78AC-G1A
(E)=
(F)=

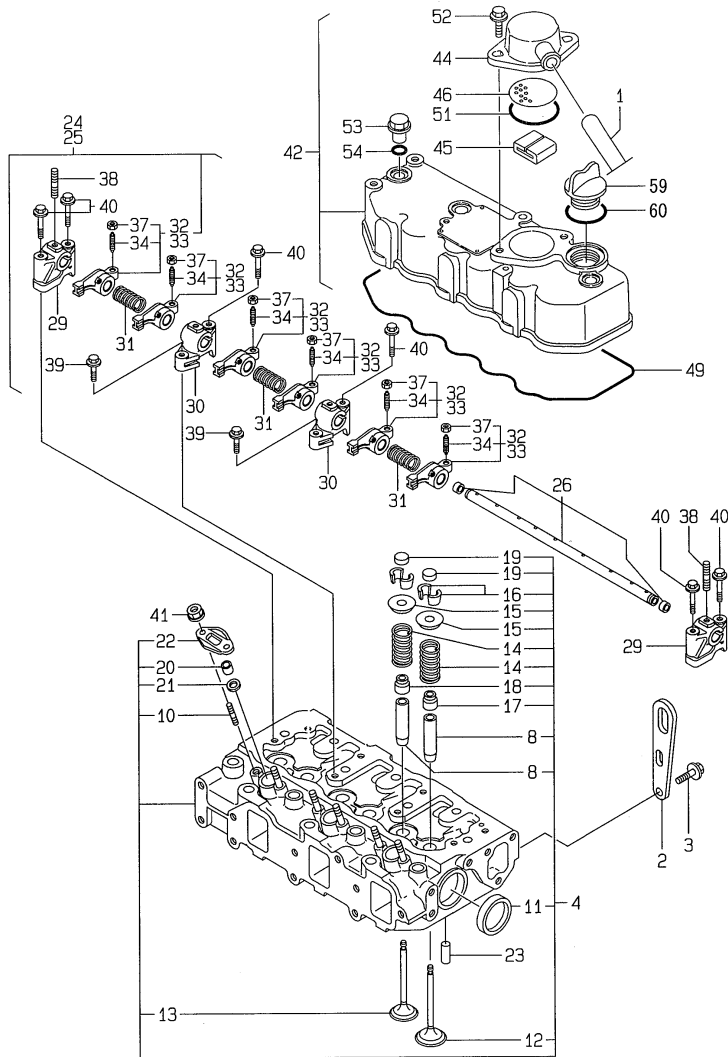

| No. | Lev. | Parts No. | Description | Q'ty | | | | | | I | R |
|----------------------------------|------|--------------|---------------------|------|-----|-----|-----|-----|-----|---|---|
| | | | | (A) | (B) | (C) | (D) | (E) | (F) | | |
| 1 | 1 | 171350-03090 | PIPE , BREATHER 900 | 1 | 1 | | 1 | | | | |
| 2 | 1 | 124736-07900 | LIFTER | 1 | 1 | | 1 | | | | |
| 3 | 1 | 26106-080142 | BOLT, M8X 14 PLATED | 2 | 2 | | 2 | | | | |
| 4 | 1 | 119812-11700 | HEAD ASSY, CYLINDER | 1 | 1 | | 1 | | | | |
| 8 | 2 | 124060-11800 | GUIDE, VALVE | 6 | 6 | | 6 | | | | 1 |
| 10 | 2 | 26216-060302 | STUD, M6X 30 | 6 | 6 | | 6 | | | | |
| 11 | 2 | 27241-400000 | PLUG, 40 | 2 | 2 | | 2 | | | | |
| 12 | 2 | 119810-11100 | VALVE, INTAKE | 3 | 3 | | 3 | | | | |
| 13 | 2 | 119810-11110 | VALVE, EXHAUST | 3 | 3 | | 3 | | | | |
| 14 | 2 | 119810-11120 | SPRING, VALVE | 6 | 6 | | 6 | | | | |
| 15 | 2 | 104211-11180 | RETAINER, SPRING | 6 | 6 | | 6 | | | | |
| 16 | 2 | 27310-070001 | COTTER, 7 | 6 | 6 | | 6 | | | | |
| 17 | 2 | 124160-11340 | SEAL, VALVE STEM | 3 | 3 | | 3 | | | | |
| 18 | 2 | 124950-11340 | SEAL, VALVE STEM | 3 | 3 | | 3 | | | | |
| 19 | 2 | 104211-11370 | CAP, VALVE | 6 | 6 | | 6 | | | | |
| 20 | 2 | 119625-11871 | PROTECTOR, NOZZLE | 3 | 3 | | 3 | | | | |
| 20-1 | 2 | 119625-11870 | PROTECTOR, NOZZLE | 3 | 3 | | 3 | | | | N |
| (A=E10705) (B=E10705) (D=E10705) | | | | | | | | | | | |
| 21 | 2 | 119625-11880 | SEAT, NOZZLE | 3 | 3 | | 3 | | | | |
| 22 | 2 | 119625-11900 | RETAINER, NOZZLE | 3 | 3 | | 3 | | | | |
| 23 | 1 | 22351-060012 | PIN, SPRING 6.0X12 | 2 | 2 | | 2 | | | | |
| 24 | 1 | 119865-11200 | SUPPORT ASSY, ARM | 1 | | | | | | | |
| 24-1 | 1 | 119865-11210 | SUPPORT ASSY | 1 | | | | | | | N |
| (A=E10705) | | | | | | | | | | | |
| 25 | 1 | 119865-11210 | SUPPORT ASSY | | 1 | | 1 | | | | |
| 26 | 2 | 119810-11240 | SHAFT ASSY, ROCKER | 1 | 1 | | 1 | | | | |
| 29 | 2 | 129155-11260 | SUPPORT, ROCKER ARM | 2 | 2 | | 2 | | | | |
| 30 | 2 | 129155-11270 | SUPPORT, ROCKER ARM | 2 | 2 | | 2 | | | | |
| 31 | 2 | 129150-11280 | SPRING | 3 | 3 | | 3 | | | | |
| 32 | 2 | 719810-11650 | ARM ASSY, ROCKER | 6 | | | | | | | |
| 32-1 | 2 | 719810-11660 | ARM ASSY, ROCKER | 6 | | | | | | | N |
| (A=E10705) | | | | | | | | | | | |
| 33 | 2 | 719810-11660 | ARM ASSY, ROCKER | | 6 | | 6 | | | | |
| 34 | 3 | 129150-11230 | SCREW, VALVE ADJUST | 6 | 6 | | 6 | | | | |
| 37 | 3 | 129150-11750 | NUT, M8 | 6 | 6 | | 6 | | | | |
| 38 | 2 | 26226-080182 | STUD, M8X 18 | 3 | 3 | | 3 | | | | |
| 39 | 1 | 26106-080252 | BOLT, M8X 25 PLATED | 2 | 2 | | 2 | | | | |
| 40 | 1 | 26106-080502 | BOLT, M8X 50 PLATED | 6 | 6 | | 6 | | | | |
| 41 | 1 | 26366-060002 | NUT, M6 | 6 | 6 | | 6 | | | | |
| 42 | 1 | 719810-11520 | BONNET ASSY, HEAD | 1 | 1 | | 1 | | | | |
| 44 | 2 | 129150-03020 | COVER, BREATHER | 1 | 1 | | 1 | | | | |
| 45 | 2 | 129150-03070 | BAFFLE, BREATHER | 1 | 1 | | 1 | | | | |
| 46 | 2 | 129150-03080 | PLATE, BAFFLE | 1 | 1 | | 1 | | | | |
| 49 | 2 | 119865-11310 | GASKET, BONNET | 1 | 1 | | 1 | | | | |
| 51 | 2 | 24341-000500 | O-RING, 1AS50.0 | 1 | 1 | | 1 | | | | |
| 52 | 2 | 26106-080162 | BOLT, M8X 16 PLATED | 2 | 2 | | 2 | | | | |
| 53 | 1 | 124160-11360 | KNOB | 3 | 3 | | 3 | | | | |
| 54 | 1 | 24311-000120 | O-RING, 1AP12.0 | 3 | 3 | | 3 | | | | |
| 59 | 1 | 124160-01751 | COVER, FILLER | 1 | 1 | | 1 | | | | |
| 60 | 1 | 24311-000320 | O-RING, 1AP32.0 | 1 | 1 | | 1 | | | | |

Remarks
(1) REPAIR PART.

(A)=3TNE78A-SA
(B)=3TNE78A-G1A
(C)=3TNE78A-G2A

(D)=3TNE78AC-G1A
(E)=
(F)=

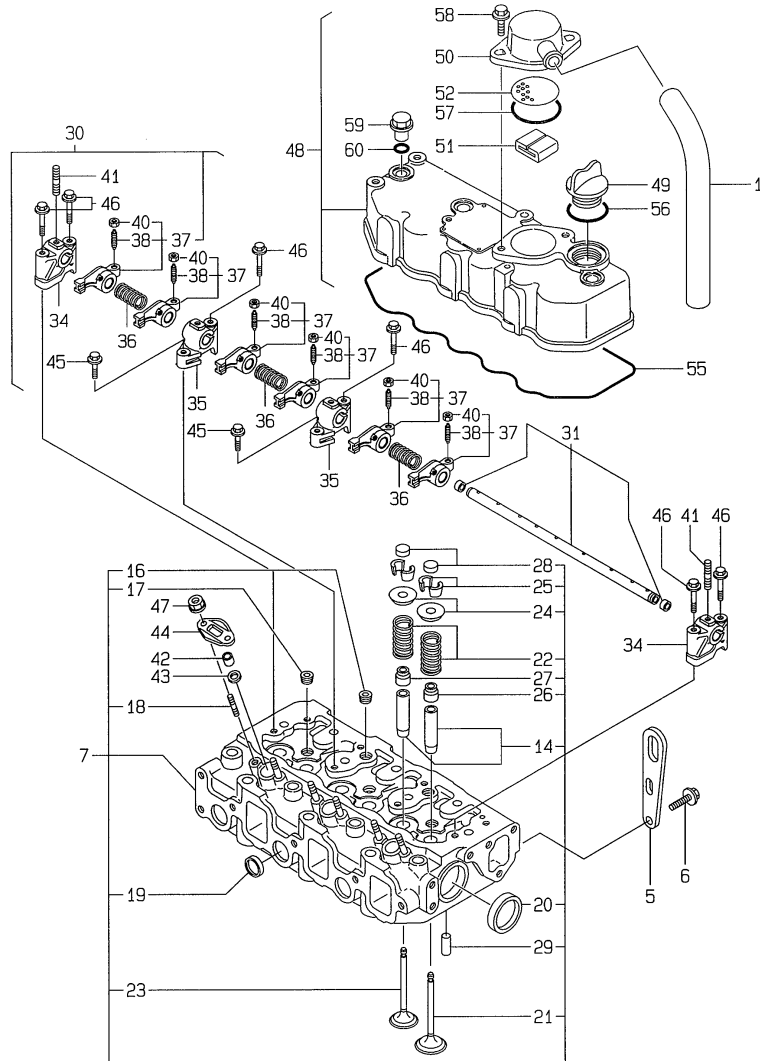

| No. | Lev. | Parts No. | Description | Q'ty | | | | | | I | R |
|------|------|--------------|-------------------------------|------|-----|-----|-----|-----|-----|---|---|
| | | | | (A) | (B) | (C) | (D) | (E) | (F) | | |
| 1 | 1 | 171350-03090 | PIPE , BREATHER 900 | | | 1 | | | | | |
| 5 | 1 | 124736-07900 | LIFTER | | | 1 | | | | | |
| 6 | 1 | 26106-080142 | BOLT, M8X 14 PLATED | | | 2 | | | | | |
| 7 | 1 | 719818-11700 | HEAD ASSY, CYLINDER | | | 1 | | | | | |
| 14 | 2 | 124060-11800 | GUIDE, VALVE | | | 6 | | | | | 1 |
| 16 | 2 | 121850-11860 | PLUG, PT1/4 | | | 2 | | | | | |
| 17 | 2 | 23871-030000 | PLUG, R03 | | | 3 | | | | | |
| 17-1 | 2 | 23876-030000 | PLUG, R03 (C=EXXX) | | | 3 | | | | | N |
| 18 | 2 | 26216-060302 | STUD, M6X 30 | | | 6 | | | | | |
| 19 | 2 | 27241-220000 | PLUG, 22 | | | 3 | | | | | |
| 20 | 2 | 27241-400000 | PLUG, 40 | | | 2 | | | | | |
| 21 | 2 | 119810-11100 | VALVE, INTAKE | | | 3 | | | | | |
| 22 | 2 | 119810-11120 | SPRING, VALVE | | | 6 | | | | | |
| 23 | 2 | 119810-11130 | VALVE, EXHAUST | | | 3 | | | | | |
| 24 | 2 | 104211-11180 | RETAINER, SPRING | | | 6 | | | | | |
| 25 | 2 | 27310-070001 | COTTER, 7 | | | 6 | | | | | |
| 26 | 2 | 124160-11340 | SEAL, VALVE STEM | | | 3 | | | | | |
| 27 | 2 | 124950-11340 | SEAL, VALVE STEM | | | 3 | | | | | |
| 28 | 2 | 104211-11370 | CAP, VALVE | | | 6 | | | | | |
| 29 | 2 | 22351-060012 | PIN, SPRING 6.0X12 | | | 2 | | | | | |
| 30 | 1 | 119865-11200 | SUPPORT ASSY, ARM | | | 1 | | | | | |
| 31 | 2 | 119810-11240 | SHAFT ASSY, ROCKER | | | 1 | | | | | |
| 34 | 2 | 129155-11260 | SUPPORT, ROCKER ARM | | | 2 | | | | | |
| 35 | 2 | 129155-11270 | SUPPORT, ROCKER ARM | | | 2 | | | | | |
| 36 | 2 | 129150-11280 | SPRING | | | 3 | | | | | |
| 37 | 2 | 719810-11650 | ARM ASSY, ROCKER | | | 6 | | | | | |
| 38 | 3 | 129150-11230 | SCREW, VALVE ADJUST | | | 6 | | | | | |
| 40 | 3 | 129150-11750 | NUT, M8 | | | 6 | | | | | |
| 41 | 2 | 26226-080182 | STUD, M8X 18 | | | 3 | | | | | |
| 42 | 1 | 119625-11871 | PROTECTOR, NOZZLE | | | 3 | | | | | |
| 42-1 | 1 | 119625-11870 | PROTECTOR, NOZZLE (C=EXXX) | | | 3 | | | | | N |
| 43 | 1 | 119625-11880 | SEAT, NOZZLE | | | 3 | | | | | |
| 44 | 1 | 119625-11900 | RETAINER, NOZZLE | | | 3 | | | | | |
| 45 | 1 | 26106-080252 | BOLT, M8X 25 PLATED | | | 2 | | | | | |
| 46 | 1 | 26106-080502 | BOLT, M8X 50 PLATED | | | 6 | | | | | |
| 47 | 1 | 26366-060002 | NUT, M6 | | | 6 | | | | | |
| 48 | 1 | 719810-11520 | BONNET ASSY, HEAD | | | 1 | | | | | |
| 49 | 2 | 124160-01751 | COVER, FILLER | | | 1 | | | | | |
| 50 | 2 | 129150-03020 | COVER, BREATHER | | | 1 | | | | | |
| 51 | 2 | 129150-03070 | BAFFLE, BREATHER | | | 1 | | | | | |
| 52 | 2 | 129150-03080 | PLATE, BAFFLE | | | 1 | | | | | |
| 55 | 2 | 119865-11310 | GASKET, BONNET | | | 1 | | | | | |
| 56 | 2 | 24311-000320 | O-RING, 1AP32.0 | | | 1 | | | | | |
| 57 | 2 | 24341-000500 | O-RING, 1AS50.0 | | | 1 | | | | | |
| 58 | 2 | 26106-080162 | BOLT, M8X 16 PLATED | | | 2 | | | | | |
| 59 | 1 | 124160-11360 | KNOB | | | 3 | | | | | |
| 60 | 1 | 24311-000120 | O-RING, 1AP12.0 | | | 3 | | | | | |

Remarks
(1) REPAIR PART.

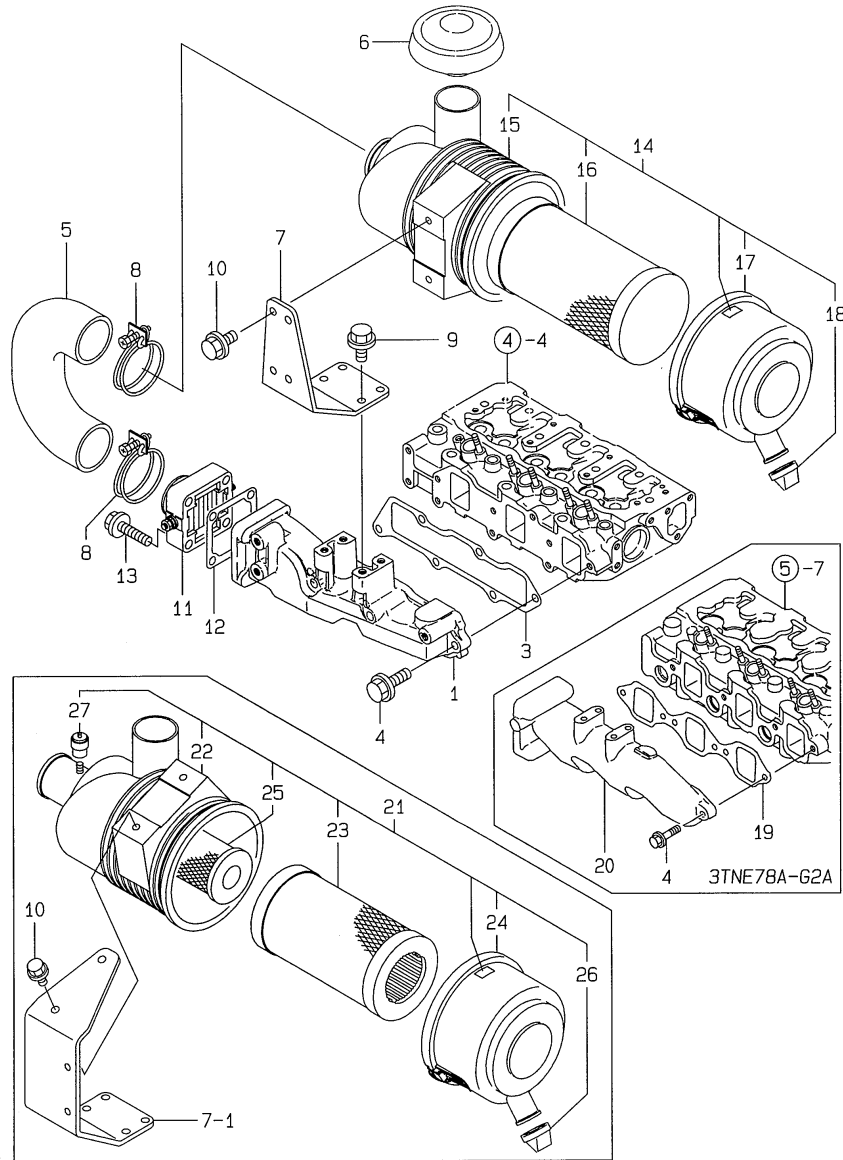

(A)=3TNE78A-SA
(B)=3TNE78A-G1A
(C)=3TNE78A-G2A

(D)=3TNE78AC-G1A
(E)=
(F)=

| No. | Lev. | Parts No. | Description | Qty | | | | | | I | R |
|------|------|---|----------------------|-----|-----|-----|-----|-----|-----|---|---|
| | | | | (A) | (B) | (C) | (D) | (E) | (F) | | |
| 1 | 1 | 119813-12100 | MANIFOLD, AIR INTAKE | 1 | 1 | | 1 | | | | |
| 3 | 1 | 119813-12110 | GASKET, MANIFOLD | 1 | 1 | | 1 | | | | |
| 4 | 1 | 26106-080252 | BOLT, M8X 25 PLATED | 6 | 6 | 4 | 6 | | | | |
| 5 | 1 | 129619-12210 | PIPE, AIR INTAKE | 1 | 1 | 1 | 1 | | | | |
| 6 | 1 | 121521-12400 | CAP, RAIN | 1 | 1 | 1 | 1 | | | | |
| 7 | 1 | 129619-12560 | BRACKET, AIR CLEANER | 1 | 1 | 1 | | | | | |
| 7-1 | 1 | 129608-12560 | BRACKET, AIR CLEANER | 1 | 1 | 1 | 1 | | | | R |
| | | (A=E12249) (B=E12274) (C=E12582) (D=E01796) | | | | | | | | | |
| 8 | 1 | 23000-060000 | CLAMP, 60 | 2 | 2 | 2 | 2 | | | | |
| 9 | 1 | 26106-080182 | BOLT, M8X 18 PLATED | 4 | 4 | 4 | 4 | | | | |
| 9-1 | 1 | 26013-080222 | BOLT, M8X 22 | 4 | 4 | 4 | 4 | | | | N |
| | | (A=E12249) (B=E12274) (C=E12582) (D=E01796) | | | | | | | | | |
| 10 | 1 | 26106-080182 | BOLT, M8X 18 PLATED | 2 | 2 | 2 | 2 | | | | |
| 10-1 | 1 | 26013-080222 | BOLT, M8X 22 | 2 | 2 | 2 | 2 | | | | N |
| | | (A=E12249) (B=E12274) (C=E12582) (D=E01796) | | | | | | | | | |
| 11 | 1 | 129120-77501 | HEATER | 1 | 1 | 1 | 1 | | | | |
| 12 | 1 | 129150-77511 | GASKET | 1 | 1 | 1 | 1 | | | | |
| 13 | 1 | 26106-080352 | BOLT, M8X 35 PLATED | 4 | 4 | 4 | 4 | | | | |
| 14 | 1 | 129608-12500 | CLEANER ASSY, AIR | 1 | 1 | 1 | | | | | |
| 14-1 | 1 | 129608-12501 | CLEANER ASSY, AIR | 1 | 1 | 1 | 1 | | | | R |
| | | (A=E12249) (B=E12274) (C=E12582) (D=E01796) | | | | | | | | | |
| 15 | 2 | 129608-12510 | BODY ASSY | 1 | 1 | 1 | | | | | |
| 15-1 | 2 | 129608-12511 | BODY, AIR CLEANER | 1 | 1 | 1 | 1 | | | | R |
| | | (A=E12249) (B=E12274) (C=E12582) (D=E01796) | | | | | | | | | |
| 16 | 2 | 119808-12520 | ELEMENT | 1 | 1 | 1 | 1 | | | | |
| 17 | 2 | 119808-12530 | COVER | 1 | 1 | 1 | 1 | | | | |
| 18 | 2 | 119808-12540 | VALVE, UNLOADER | 1 | 1 | 1 | 1 | | | | |
| 19 | 1 | 119810-12111 | GASKET, MANIFOLD | | | | 1 | | | | |
| 20 | 1 | 171301-12701 | MANIFOLD, AIR INTAKE | | | | 1 | | | | |
| 21 | 1 | 119822-12500 | CLEANER ASSY, AIR | 1 | 1 | 1 | 1 | | | | W |
| | | (A=E12249) (B=E12274) (C=E12582) (D=E01796) | | | | | | | | | |
| 22 | 2 | 119822-12510 | BODY, AIR CLEANER | 1 | 1 | 1 | 1 | | | | W |
| | | (A=E12249) (B=E12274) (C=E12582) (D=E01796) | | | | | | | | | |
| 23 | 2 | 119808-12520 | ELEMENT | 1 | 1 | 1 | 1 | | | | W |
| | | (A=E12249) (B=E12274) (C=E12582) (D=E01796) | | | | | | | | | |
| 24 | 2 | 119808-12530 | COVER | 1 | 1 | 1 | 1 | | | | W |
| | | (A=E12249) (B=E12274) (C=E12582) (D=E01796) | | | | | | | | | |
| 25 | 2 | 129051-12530 | ELEMENT | 1 | 1 | 1 | 1 | | | | W |
| | | (A=E12249) (B=E12274) (C=E12582) (D=E01796) | | | | | | | | | |
| 26 | 2 | 119808-12540 | VALVE, UNLOADER | 1 | 1 | 1 | 1 | | | | W |
| | | (A=E12249) (B=E12274) (C=E12582) (D=E01796) | | | | | | | | | |
| 27 | 2 | 126650-12680 | INDICATOR | 1 | 1 | 1 | 1 | | | | W |
| | | (A=E12249) (B=E12274) (C=E12582) (D=E01796) | | | | | | | | | |

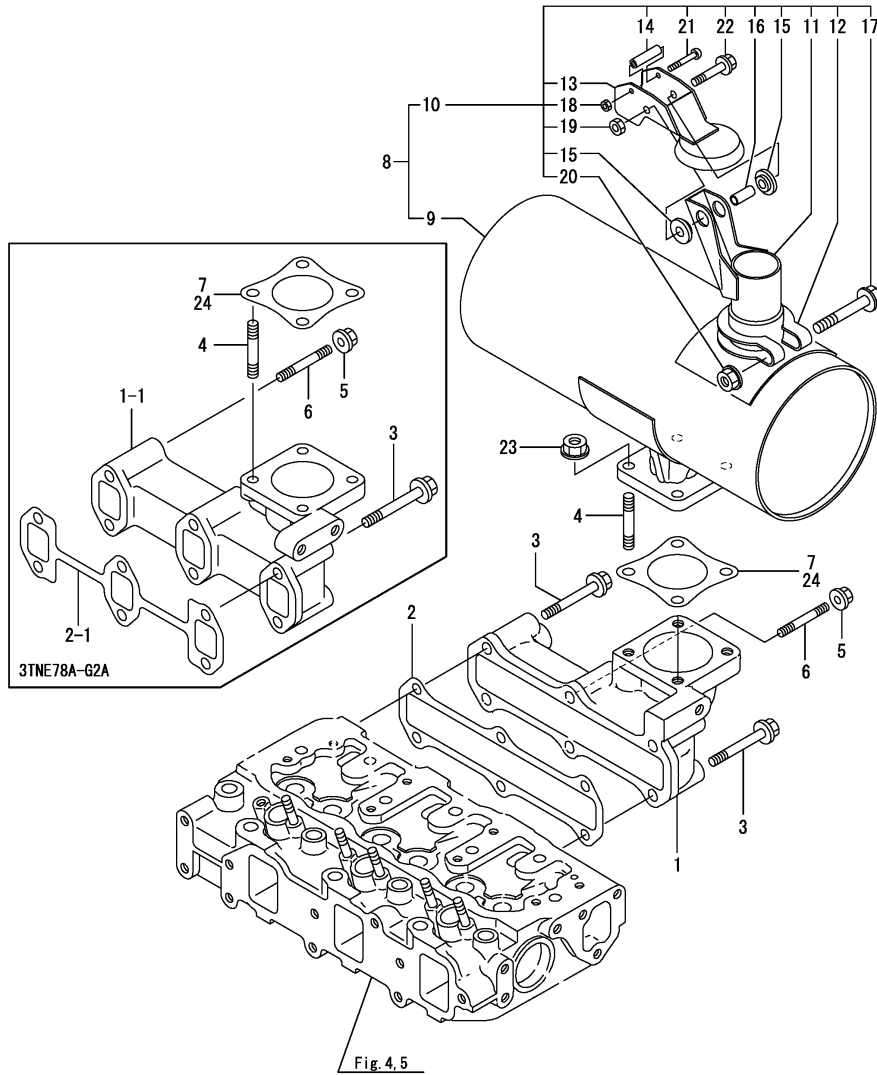

| No. | Lev. | Parts No. | Description | Qty | | | | | | I | R |
|------|------|--------------|-----------------------------------|------------|------------|-----|-----|-----|-----|---|---|
| | | | | (A) | (B) | (C) | (D) | (E) | (F) | | |
| 1 | 1 | 119813-13100 | MANIFOLD, EXHAUST | 1 | 1 | 1 | 1 | | | | |
| 1-1 | 1 | 119888-13101 | MANIFOLD, EXHAUST (C=FROM 1ST) | | | 1 | | | | | S |
| 2 | 1 | 119813-13110 | GASKET | 1 | 1 | 1 | 1 | | | | |
| 2-1 | 1 | 119810-13110 | GASKET (C=FROM 1ST) | | | 1 | | | | | S |
| 3 | 1 | 26106-080602 | BOLT, M8X 60 PLATED | 4 | 4 | 4 | 4 | | | | |
| 4 | 1 | 26216-080222 | STUD, M8X 22 | 4 | 4 | 4 | 4 | | | | |
| 4-1 | 1 | 119131-18320 | STUD, M8X22 | 4 | 4 | 4 | 4 | | | | N |
| | | (A=E14436) | (B=E14407) | (C=E14408) | (D=E01796) | | | | | | |
| 5 | 1 | 194990-22050 | NUT, M8 | 2 | 2 | 2 | 2 | | | | |
| 5-1 | 1 | 26366-080002 | NUT, M8 | 2 | 2 | 2 | 2 | | | | R |
| | | (A=E14436) | (B=E14407) | (C=E14408) | (D=E01796) | | | | | | |
| 5-2 | 1 | 26306-080002 | NUT, M8 | 2 | 2 | 2 | 2 | | | | N |
| | | (A=E14436) | (B=E14407) | (C=E14408) | (D=E01796) | | | | | | |
| 6 | 1 | 26216-080602 | STUD, M8X 60 | 2 | 2 | 2 | 2 | | | | |
| 7 | 1 | 121000-13201 | GASKET, SILENCER | 1 | 1 | 1 | 1 | | | | |
| 7-1 | 1 | 124701-11911 | GASKET, SILENCER | 1 | 1 | 1 | 1 | | | | R |
| | | (A=E14436) | (B=E14407) | (C=E14408) | (D=E01796) | | | | | | |
| 8 | 1 | 119620-13501 | SILENCER | 1 | 1 | 1 | 1 | | | | |
| 9 | 2 | 119620-13510 | SILENCER ASSY | 1 | 1 | 1 | 1 | | | | |
| 10 | 2 | 119620-13520 | PIPE ASSY, TAIL | 1 | 1 | 1 | 1 | | | | |
| 11 | 3 | 119620-13560 | PIPE, TAIL | 1 | 1 | 1 | 1 | | | | |
| 12 | 3 | 124664-13580 | CLAMP | 1 | 1 | 1 | 1 | | | | |
| 13 | 3 | 119358-13640 | CAP, RAIN | 1 | 1 | 1 | 1 | | | | |
| 14 | 3 | 121855-13821 | SPACER, A | 1 | 1 | 1 | 1 | | | | |
| 15 | 3 | 121855-13830 | SPACER, B | 2 | 2 | 2 | 2 | | | | |
| 16 | 3 | 123500-13840 | SPACER, C | 1 | 1 | 1 | 1 | | | | |
| 17 | 3 | 26106-080552 | BOLT, M8X 55 PLATED | 1 | 1 | 1 | 1 | | | | |
| 18 | 3 | 26347-040002 | NUT, M4 | 1 | 1 | 1 | 1 | | | | |
| 19 | 3 | 26347-060002 | NUT, M6 | 1 | 1 | 1 | 1 | | | | |
| 20 | 3 | 26366-080002 | NUT, M8 | 1 | 1 | 1 | 1 | | | | |
| 20-1 | 3 | 26306-080002 | NUT, M8 | 1 | 1 | 1 | 1 | | | | N |
| | | (A=E14436) | (B=E14407) | (C=E14408) | (D=E01796) | | | | | | |
| 21 | 3 | 26557-040352 | SCREW, M4X35 | 1 | 1 | 1 | 1 | | | | |
| 22 | 3 | 26106-060402 | BOLT, M6X 40 PLATED | 1 | 1 | 1 | 1 | | | | |
| 23 | 1 | 194990-22050 | NUT, M8 | 4 | 4 | 4 | 4 | | | | |
| 23-1 | 1 | 26366-080002 | NUT, M8 | 4 | 4 | 4 | 4 | | | | R |
| | | (A=E14436) | (B=E14407) | (C=E14408) | (D=E01796) | | | | | | |
| 23-2 | 1 | 26306-080002 | NUT, M8 | 4 | 4 | 4 | 4 | | | | N |
| | | (A=E14436) | (B=E14407) | (C=E14408) | (D=E01796) | | | | | | |
| 24 | 1 | 121000-13201 | GASKET, SILENCER | 1 | 1 | 1 | 1 | | | | 1 |

Remarks
(1) LOOSE PART.

(A)=3TNE78A-SA
(B)=3TNE78A-G1A
(C)=3TNE78A-G2A

(D)=3TNE78AC-G1A
(E)=
(F)=

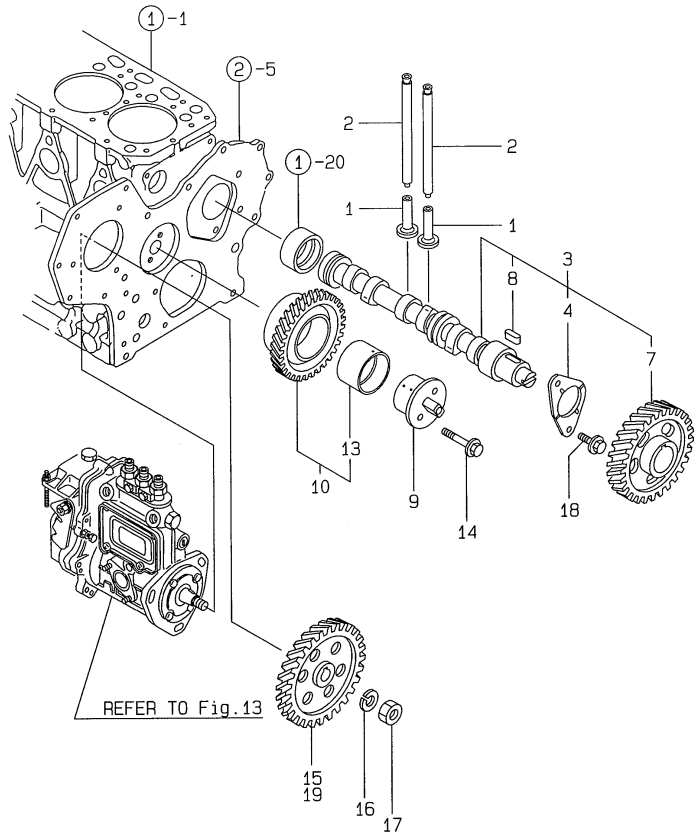

| No. | Lev. | Parts No. | Description | Q'ty | | | | | | I | R |
|------|------|--------------|---------------------|------------|------------|-----|-----|-----|-----|---|---|
| | | | | (A) | (B) | (C) | (D) | (E) | (F) | | |
| 1 | 1 | 129150-14200 | TAPPET | 6 | 6 | 6 | 6 | | | | |
| 2 | 1 | 119810-14400 | ROD, PUSH | 6 | 6 | 6 | 6 | | | | |
| 3 | 1 | 119810-14580 | CAMSHAFT ASSY | 1 | 1 | 1 | 1 | | | | |
| 4 | 2 | 129150-02450 | BEARING, THRUST | 1 | 1 | 1 | 1 | | | | |
| 7 | 2 | 129150-14101 | GEAR, CAMSHAFT | 1 | 1 | 1 | 1 | | | | |
| 8 | 2 | 22512-070140 | KEY, 7X 14 | 1 | 1 | 1 | 1 | | | | |
| 9 | 1 | 129100-25061 | SHAFT, IDLE | 1 | 1 | 1 | 1 | | | | |
| 10 | 1 | 129150-25101 | GEAR ASSY, IDLE | 1 | 1 | 1 | 1 | | | | |
| 13 | 2 | 129150-25920 | BUSH, IDLE GEAR | 1 | 1 | 1 | 1 | | | 1 | |
| 14 | 1 | 26106-080452 | BOLT, M8X 45 PLATED | 2 | 2 | 2 | 2 | | | | |
| 15 | 1 | 129150-25900 | GEAR, PUMP | 1 | 1 | | 1 | | | | |
| 16 | 1 | 22217-120000 | WASHER, SPRING 12 | 1 | 1 | 1 | 1 | | | | |
| 17 | 1 | 26716-120002 | NUT, M12 | 1 | 1 | 1 | 1 | | | | |
| 18 | 1 | 26106-080162 | BOLT, M8X 16 PLATED | 2 | 2 | 2 | 2 | | | | |
| 18-1 | 1 | 26106-080142 | BOLT, M8X 14 PLATED | 2 | 2 | 2 | 2 | | | N | |
| | | (A=E10463) | (B=E10615) | (C=E12582) | (D=E00973) | | | | | | |
| 19 | 1 | 129100-25900 | GEAR, PUMP | | | 1 | | | | | |

Remarks
(1) REPAIR PART.

(A)=3TNE78A-SA
(B)=3TNE78A-G1A
(C)=3TNE78A-G2A

(D)=3TNE78AC-G1A
(E)=
(F)=

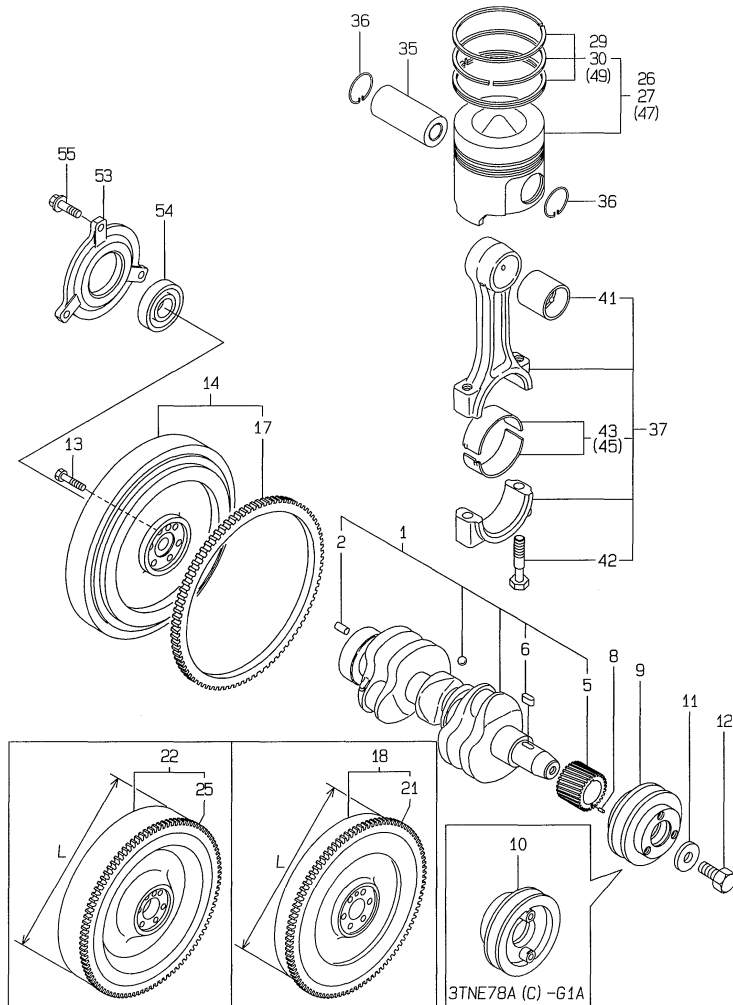

| No. | Lev. | Parts No. | Description | Q'ty | | | | | | I | R |
|-----|------|--------------|----------------------|------|-----|-----|-----|-----|-----|---|---|
| | | | | (A) | (B) | (C) | (D) | (E) | (F) | | |
| 1 | 1 | 119813-21000 | CRANKSHAFT ASSY | 1 | 1 | 1 | 1 | | | | |
| 2 | 2 | 129100-01580 | PIN, M8X16 | 1 | 1 | 1 | 1 | | | | |
| 5 | 2 | 129150-21200 | GEAR, CRANKSHAFT | 1 | 1 | 1 | 1 | | | | |
| 6 | 2 | 22512-070140 | KEY, 7X 14 | 1 | 1 | 1 | 1 | | | | |
| 8 | 1 | 22351-040010 | PIN, SPRING 4.0X10 | 1 | 1 | 1 | 1 | | | | |
| 9 | 1 | 171301-21650 | V-PULLEY | 1 | | 1 | | | | | |
| 10 | 1 | 129550-21650 | V-PULLEY | | 1 | | 1 | | | | |
| 11 | 1 | 129795-21661 | WASHER | 1 | 1 | 1 | 1 | | | | |
| 12 | 1 | 121850-21680 | BOLT | 1 | 1 | 1 | 1 | | | | |
| 13 | 1 | 121111-21501 | BOLT, FLYWHEEL | 6 | 6 | 6 | 6 | | | | |
| 14 | 1 | 119888-21590 | FLYWHEEL ASSY | 1 | | 1 | | | | | |
| 17 | 2 | 119865-21600 | GEAR, RING | 1 | | 1 | | | | | |
| 18 | 1 | 171301-21590 | FLYWHEEL ASSY | 1 | 1 | 1 | 1 | | | 1 | |
| 21 | 2 | 124550-21600 | GEAR, RING | 1 | 1 | 1 | 1 | | | 1 | |
| 22 | 1 | 171301-21580 | FLYWHEEL ASSY | 1 | | 1 | | | | 2 | |
| 25 | 2 | 119865-21600 | GEAR, RING | 1 | | 1 | | | | 2 | |
| 26 | 1 | 119818-22080 | PISTON ASSY | 3 | 3 | | 3 | | | | |
| 27 | 1 | 119818-22090 | PISTON ASSY | | | 3 | | | | | |
| 29 | 2 | 119818-22500 | RING SET, PISTON | 3 | 3 | | 3 | | | | |
| 30 | 2 | 119818-22510 | RING SET, PISTON | | | 3 | | | | | |
| 35 | 1 | 119813-22300 | PIN, PISTON | 3 | 3 | 3 | 3 | | | | |
| 36 | 1 | 129792-22400 | CIRCLIP, 23 | 6 | 6 | 6 | 6 | | | | |
| 37 | 1 | 719810-23100 | ROD ASSY, CONNECTING | 3 | 3 | 3 | 3 | | | | |
| 41 | 2 | 119810-23910 | BEARING, PISTON PIN | 3 | 3 | 3 | 3 | | | 3 | |
| 42 | 2 | 119810-23200 | BOLT, CONNECTING ROD | 6 | 6 | 6 | 6 | | | | |
| 43 | 2 | 119810-23600 | BEARING, CRANK PIN | 3 | 3 | 3 | 3 | | | | |
| 45 | 1 | 119810-23610 | BEARING, 0.25 US | 3 | 3 | 3 | 3 | | | 4 | |
| 47 | 1 | 119818-22900 | PISTON ASSY, 0.25 OS | 3 | 3 | 3 | 3 | | | 5 | |
| 49 | 2 | 119818-22950 | RING SET, 0.25 OS | 3 | 3 | 3 | 3 | | | 5 | |
| 53 | 1 | 119888-21450 | RETAINER, BEARING | 1 | | | | | | | |
| 54 | 1 | 24104-062054 | BEARING, BALL 6205UU | 1 | | | | | | | |
| 55 | 1 | 26106-080222 | BOLT, M8X 22 PLATED | 3 | | | | | | | |

Remarks

- (1) L= 335M/M.
- (2) L= 300M/M.
- (3) REPAIR PART.
- (4) UNDER-SIZE(U.S=0.25)PART.
- (5) OVER-SIZE(O.S=0.25)PART.

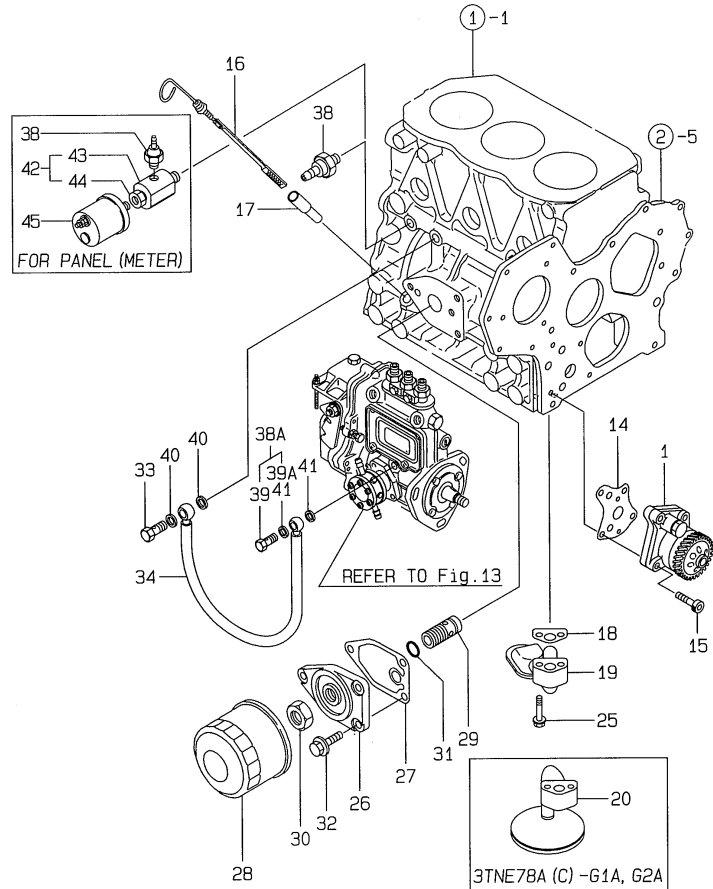

| No. | Lev. | Parts No. | Description | Q'ty | | | | | | I | R |
|------|------|--------------|--|------|-----|-----|-----|-----|-----|---|-----|
| | | | | (A) | (B) | (C) | (D) | (E) | (F) | | |
| 1 | 1 | 129001-32001 | PUMP ASSY, OIL | 1 | 1 | 1 | 1 | | | | |
| 14 | 1 | 129150-32020 | GASKET, PUMP | 1 | 1 | 1 | 1 | | | | |
| 15 | 1 | 26450-060252 | BOLT, M6X 25 | 4 | 4 | 4 | 4 | | | | |
| 16 | 1 | 119600-34800 | DIPSTICK, OIL | 1 | 1 | 1 | 1 | | | | |
| 16-1 | 1 | 171420-34820 | DIPSTICK, OIL (C=FROM 1ST) | | | 1 | | | | | N |
| 17 | 1 | 121520-34810 | GUIDE, DIPSTICK | 1 | 1 | 1 | 1 | | | | |
| 18 | 1 | 129150-35041 | GASKET | 1 | 1 | 1 | 1 | | | | |
| 19 | 1 | 119810-35401 | PIPE ASSY, OIL INLET | 1 | | | | | | | |
| 20 | 1 | 119810-35300 | PIPE ASSY, OIL INLET | | 1 | 1 | 1 | | | | |
| 25 | 1 | 26106-080352 | BOLT, M8X 35 PLATED | 2 | 2 | 2 | 2 | | | | |
| 26 | 1 | 129150-35101 | BRACKET, STRAINER | 1 | 1 | 1 | 1 | | | | |
| 27 | 1 | 129150-35111 | GASKET | 1 | 1 | 1 | 1 | | | | |
| 28 | 1 | 129150-35151 | FILTER, D80XL80 | 1 | 1 | 1 | 1 | | | | |
| 29 | 1 | 129001-35300 | BOLT, FILTER | 1 | 1 | 1 | 1 | | | | |
| 30 | 1 | 129150-35350 | NUT | 1 | 1 | 1 | 1 | | | | |
| 31 | 1 | 24311-000160 | O-RING, 1AP16.0 | 1 | 1 | 1 | 1 | | | | |
| 32 | 1 | 26106-080202 | BOLT, M8X 20 PLATED | 3 | 3 | 3 | 3 | | | | |
| 33 | 1 | 124160-39140 | BOLT, PIPE JOINT M10 | 1 | 1 | 1 | 1 | | | | |
| 34 | 1 | 119810-39200 | PIPE ASSY, OIL | 1 | 1 | 1 | 1 | | | | |
| 38 | 1 | 124160-39450 | SWITCH, 0.5KG | 1 | 1 | 1 | 1 | | | | |
| 38A | 1 | 124550-59830 | BOLT ASSY, JOINT M8 (A=E10463) (B=E10615) (C=E12582) (D=E00973) | 1 | 1 | 1 | 1 | | | | W |
| 39 | 2 | 124550-59820 | BOLT, PIPE JOINT M8 | 1 | 1 | 1 | 1 | | | | |
| 39A | 2 | 22190-080002 | WASHER, SEAL 6 (A=E10463) (B=E10615) (C=E12582) (D=E00973) | 1 | 1 | 1 | 1 | | | | W |
| 40 | 1 | 23414-100000 | GASKET, 10X1.0 | 2 | 2 | 2 | 2 | | | | |
| 41 | 1 | 22190-080002 | WASHER, SEAL 6 | 2 | 2 | 2 | 2 | | | | |
| 41-1 | 1 | 22190-080002 | WASHER, SEAL 6 (A=E10463) (B=E10615) (C=E12582) (D=E00973) | 1 | 1 | 1 | 1 | | | | K |
| 42 | 1 | 171375-39600 | DAMPER ASSY | 1 | 1 | 1 | 1 | | | | 1 |
| 42-1 | 1 | 171375-39601 | DAMPER, 1/8 (A=E10463) (B=E10615) (C=E12582) (D=E00973) | 1 | 1 | 1 | 1 | | | | R 1 |
| 43 | 2 | 129470-39610 | DAMPER (A=E10463) (B=E10615) (C=E12582) (D=E00973) | 1 | 1 | 1 | 1 | | | | Z 1 |
| 44 | 2 | 23161-020100 | BUSH, R1/4X1/8 (A=E10463) (B=E10615) (C=E12582) (D=E00973) | 1 | 1 | 1 | 1 | | | | Z 1 |
| 45 | 1 | 144626-91560 | SENSOR | 1 | 1 | 1 | 1 | | | | 1 |

Remarks
(1) FOR PANEL(METER).

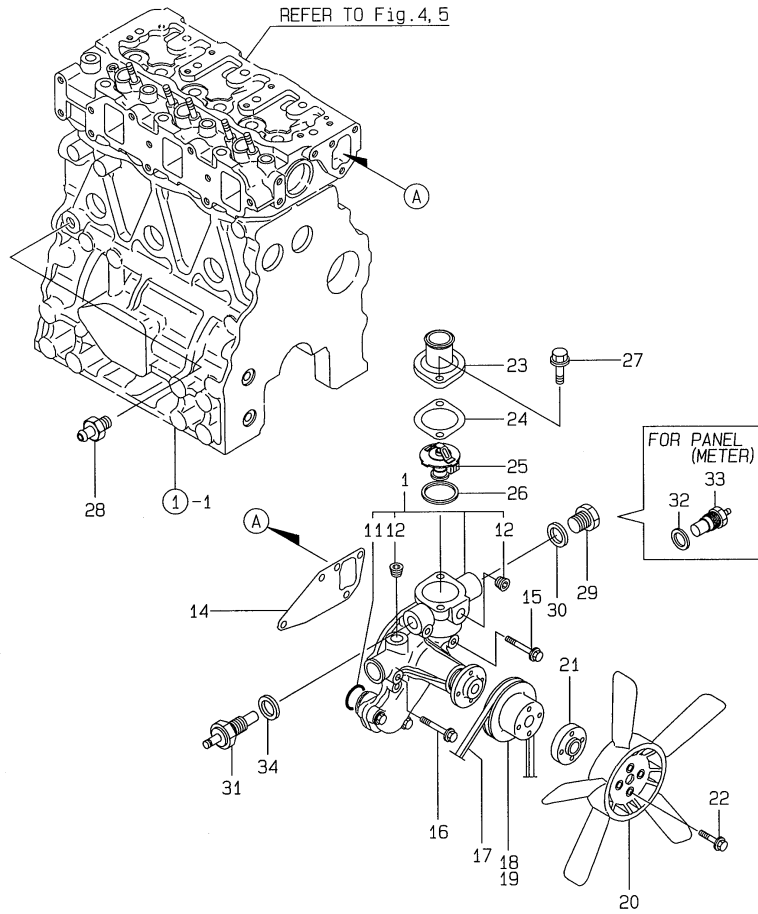

(A)=3TNE78A-SA
(B)=3TNE78A-G1A
(C)=3TNE78A-G2A

(D)=3TNE78AC-G1A
(E)=
(F)=

| No. | Lev. | Parts No. | Description | Q'ty | | | | | | I | R |
|------|------|-------------------------------------|---------------------|------|-----|-----|-----|-----|-----|---|---|
| | | | | (A) | (B) | (C) | (D) | (E) | (F) | | |
| 1 | 1 | 119810-42001 | PUMP ASSY, WATER | 1 | 1 | 1 | 1 | | | | |
| 11 | 2 | 129150-42320 | O-RING | 1 | 1 | 1 | 1 | | | | |
| 12 | 2 | 23871-030000 | PLUG, R03 | 2 | 2 | 2 | 2 | | | | |
| 12-1 | 2 | 23876-030000 | PLUG, R03 | 2 | 2 | 2 | 2 | | | | N |
| | | (A=EXXX) (B=EXXX) (C=EXXX) (D=EXXX) | | | | | | | | | |
| 14 | 1 | 129150-42020 | GASKET, WATER PUMP | 1 | 1 | 1 | 1 | | | | |
| 15 | 1 | 26106-080352 | BOLT, M8X 35 PLATED | 1 | 1 | 1 | 1 | | | | |
| 16 | 1 | 26106-080552 | BOLT, M8X 55 PLATED | 3 | 3 | 3 | 3 | | | | |
| 17 | 1 | 25132-003900 | V-BELT, A39 | 1 | 1 | 1 | 1 | | | | |
| 18 | 1 | 129403-42380 | V-PULLEY, D=110 | 1 | | | 1 | | | | |
| 19 | 1 | 129155-42350 | V-PULLEY | | 1 | | 1 | | | | |
| 20 | 1 | 124700-44740 | FAN, COOLING 5X310 | 1 | 1 | 1 | 1 | | | | |
| 21 | 1 | 124574-44761 | SPACER, FAN | 1 | 1 | 1 | 1 | | | | |
| 22 | 1 | 26106-060202 | BOLT, M6X 20 PLATED | 4 | 4 | 4 | 4 | | | | |
| 23 | 1 | 129350-49530 | COVER, THERMOSTAT | 1 | 1 | 1 | 1 | | | | |
| 24 | 1 | 129795-49551 | GASKET | 1 | 1 | 1 | 1 | | | | |
| 25 | 1 | 129155-49800 | THERMOSTAT, 71 | 1 | 1 | 1 | 1 | | | | |
| 26 | 1 | 129150-49811 | GASKET, THERMOSTAT | 1 | 1 | 1 | 1 | | | | |
| 27 | 1 | 26106-080202 | BOLT, M8X 20 PLATED | 2 | 2 | 2 | 2 | | | | |
| 27-1 | 1 | 26106-080222 | BOLT, M8X 22 PLATED | 2 | 2 | 2 | 2 | | | | N |
| | | (A=EXXX) (B=EXXX) (C=EXXX) (D=EXXX) | | | | | | | | | |
| 28 | 1 | 121550-49111 | JOINT, PT1/4 | 1 | 1 | 1 | 1 | | | | |
| 29 | 1 | 121450-42450 | PLUG, M16 | 1 | 1 | 1 | 1 | | | | |
| 30 | 1 | 124465-44950 | GASKET, 16 | 1 | 1 | 1 | 1 | | | | |
| 31 | 1 | 124250-49351 | SENSOR | 1 | 1 | 1 | 1 | | | | |
| 32 | 1 | 129150-49360 | GASKET | 1 | 1 | 1 | 1 | | | | 1 |
| 33 | 1 | 121250-44901 | SWITCH, 110 | 1 | 1 | 1 | 1 | | | | 1 |
| 34 | 1 | 124465-44950 | GASKET, 16 | 1 | 1 | 1 | 1 | | | | |

Remarks
(1) FOR PANEL(METER).

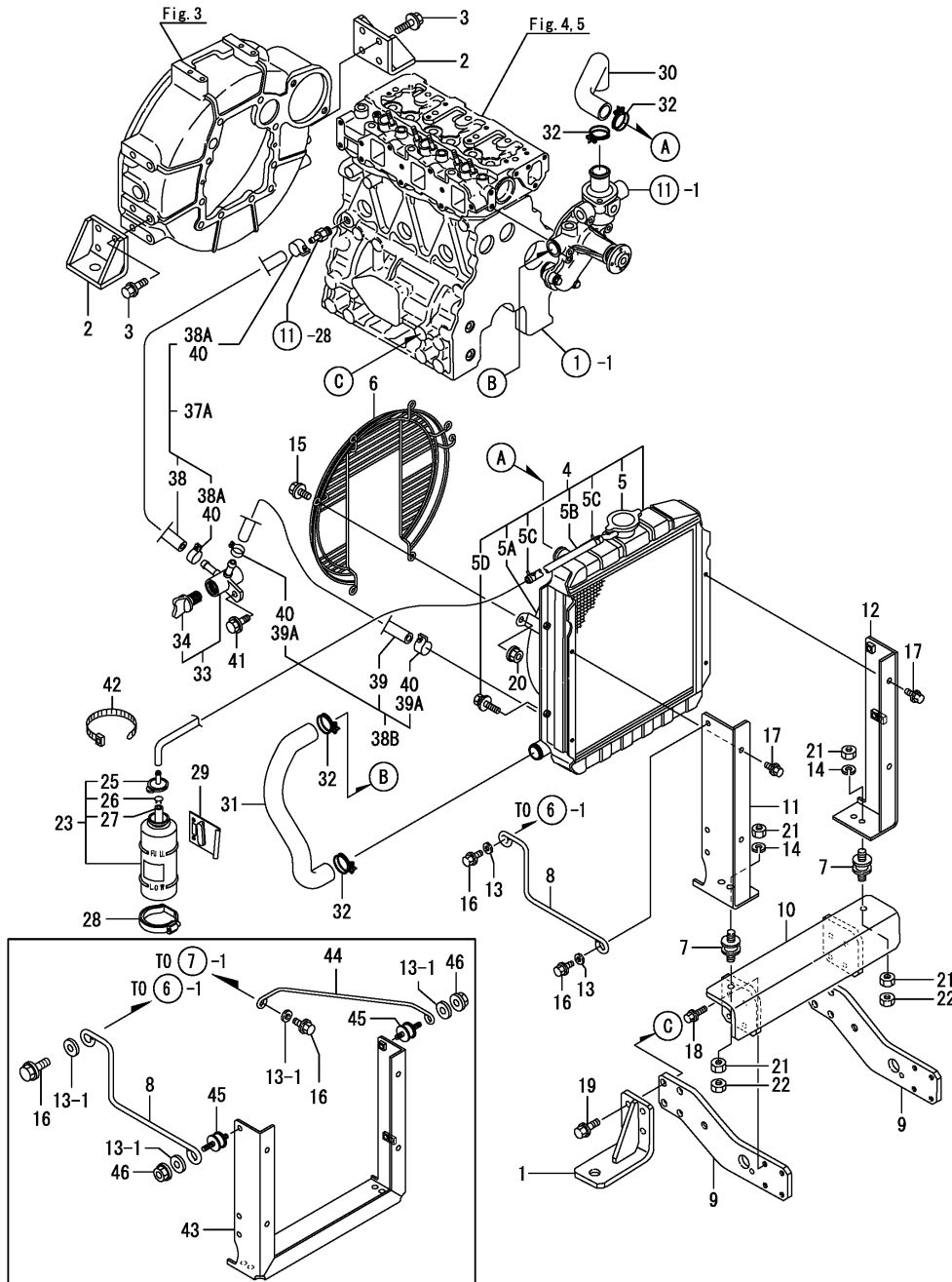

| No. | Lev. | Parts No. | Description | Q'ty | | | | | | I | R |
|------|------|-------------------------------------|----------------------|------|-----|-----|-----|-----|-----|---|---|
| | | | | (A) | (B) | (C) | (D) | (E) | (F) | | |
| 1 | 1 | 119888-08100 | FOOT | 2 | 2 | | 2 | | | | |
| 2 | 1 | 119888-08110 | FOOT | 2 | 2 | | 2 | | | | |
| 3 | 1 | 26106-100202 | BOLT, M10X 20 PLATED | 8 | 8 | | 8 | | | | |
| 4 | 1 | 119621-44500 | RADIATOR | 1 | 1 | 1 | 1 | | | | |
| 5 | 2 | 119259-44570 | CAP, RADIATOR | 1 | 1 | 1 | 1 | | | | |
| 5A | 2 | X2411365340 | SHROUD | 1 | 1 | 1 | 1 | | | | W |
| | | (A=EXXX) (B=EXXX) (C=EXXX) (D=EXXX) | | | | | | | | | |
| 5B | 2 | 129132-44530 | HOSE, RUBBER | 1 | 1 | 1 | 1 | | | | W |
| | | (A=EXXX) (B=EXXX) (C=EXXX) (D=EXXX) | | | | | | | | | |
| 5C | 2 | 121250-44590 | CLAMP | 2 | 2 | 2 | 2 | | | | W |
| | | (A=EXXX) (B=EXXX) (C=EXXX) (D=EXXX) | | | | | | | | | |
| 5D | 2 | 26014-080162 | BOLT, M8X 16 | 4 | 4 | 4 | 4 | | | | W |
| | | (A=EXXX) (B=EXXX) (C=EXXX) (D=EXXX) | | | | | | | | | |
| 6 | 1 | 119621-44560 | GUARD | 1 | 1 | 1 | 1 | | | | |
| 7 | 1 | 121400-44650 | ABSORBER | 2 | 2 | | 2 | | | | |
| 8 | 1 | 119822-44940 | RETAINER, RADIATOR | 1 | 1 | | 1 | | | | |
| 9 | 1 | 119888-44950 | BRACKET | 2 | 2 | | 2 | | | | |
| 10 | 1 | 119888-44960 | BRACKET | 1 | 1 | | 1 | | | | |
| 11 | 1 | 119888-44970 | SUPPORT, A | 1 | 1 | | 1 | | | | Z |
| | | (A=EZZZZZ) (B=EZZZZZ) (D=EZZZZZ) | | | | | | | | | |
| 12 | 1 | 119888-44980 | SUPPORT, B | 1 | 1 | | 1 | | | | Z |
| | | (A=EZZZZZ) (B=EZZZZZ) (D=EZZZZZ) | | | | | | | | | |
| 13 | 1 | 22137-080000 | WASHER, 8 | 2 | 2 | | 2 | | | | |
| 13-1 | 1 | 22137-080000 | WASHER, 8 | 4 | 4 | | 4 | | | | K |
| | | (A=EZZZZZ) (B=EZZZZZ) (D=EZZZZZ) | | | | | | | | | |
| 14 | 1 | 22217-100000 | WASHER, SPRING 10 | 2 | 2 | | 2 | | | | |
| 15 | 1 | 26106-080122 | BOLT, M8X 12 PLATED | 6 | 6 | 6 | 6 | | | | |
| 16 | 1 | 26106-080162 | BOLT, M8X 16 PLATED | 2 | 2 | | 2 | | | | |
| 17 | 1 | 26106-080202 | BOLT, M8X 20 PLATED | 4 | 4 | | 4 | | | | |
| 18 | 1 | 26106-080252 | BOLT, M8X 25 PLATED | 8 | 8 | | 8 | | | | |
| 19 | 1 | 26206-120302 | BOLT, M12X 30 PLATED | 8 | 8 | | 8 | | | | |
| 20 | 1 | 26366-080002 | NUT, M8 | 6 | 6 | 6 | 6 | | | | |
| 20-1 | 1 | 26306-080002 | NUT, M8 | 6 | 6 | 6 | 6 | | | | N |
| | | (A=EXXX) (B=EXXX) (C=EXXX) (D=EXXX) | | | | | | | | | |
| 21 | 1 | 26716-100002 | NUT, M10 | 4 | 4 | | 4 | | | | |
| 22 | 1 | 26756-100002 | NUT, LOCK M10 | 2 | 2 | | 2 | | | | |
| 23 | 1 | 124450-44510 | TANK ASSY, SUB | 1 | 1 | 1 | 1 | | | | |
| 25 | 2 | 124450-44530 | CAP | 1 | 1 | 1 | 1 | | | | |
| 26 | 2 | 124450-44560 | RETAINER | 1 | 1 | 1 | 1 | | | | |
| 27 | 2 | 23061-070230 | PIPE, 7X 230 | 1 | 1 | 1 | 1 | | | | |
| 28 | 1 | 124450-44550 | BAND | 1 | 1 | 1 | 1 | | | | |
| 29 | 1 | 121256-44600 | BRACKET, SUB TANK | 1 | 1 | 1 | 1 | | | | |
| 30 | 1 | 171301-49010 | PIPE, WATER | 1 | 1 | 1 | 1 | | | | |
| 31 | 1 | 171301-49020 | PIPE, WATER | 1 | 1 | 1 | 1 | | | | |
| 32 | 1 | 23010-038000 | CLAMP, 38 | 4 | 4 | 4 | 4 | | | | |
| 33 | 1 | 129150-49100 | COCK ASSY, 3-WAY | 1 | 1 | 1 | 1 | | | | |
| 34 | 2 | 129150-49080 | COCK, DRAIN | 1 | 1 | 1 | 1 | | | | |
| 37A | 1 | 129210-49280 | PIPE ASSY, DRAIN | 1 | 1 | 1 | 1 | | | | W |
| | | (A=EXXX) (B=EXXX) (D=EXXX) | | | | | | | | | |
| 38 | 2 | 121737-49160 | PIPE, WATER DRAIN | 1 | 1 | | 1 | | | | |
| 38A | 2 | 124766-59050 | CLIP, HOSE 12 | 2 | 2 | | 2 | | | | W |

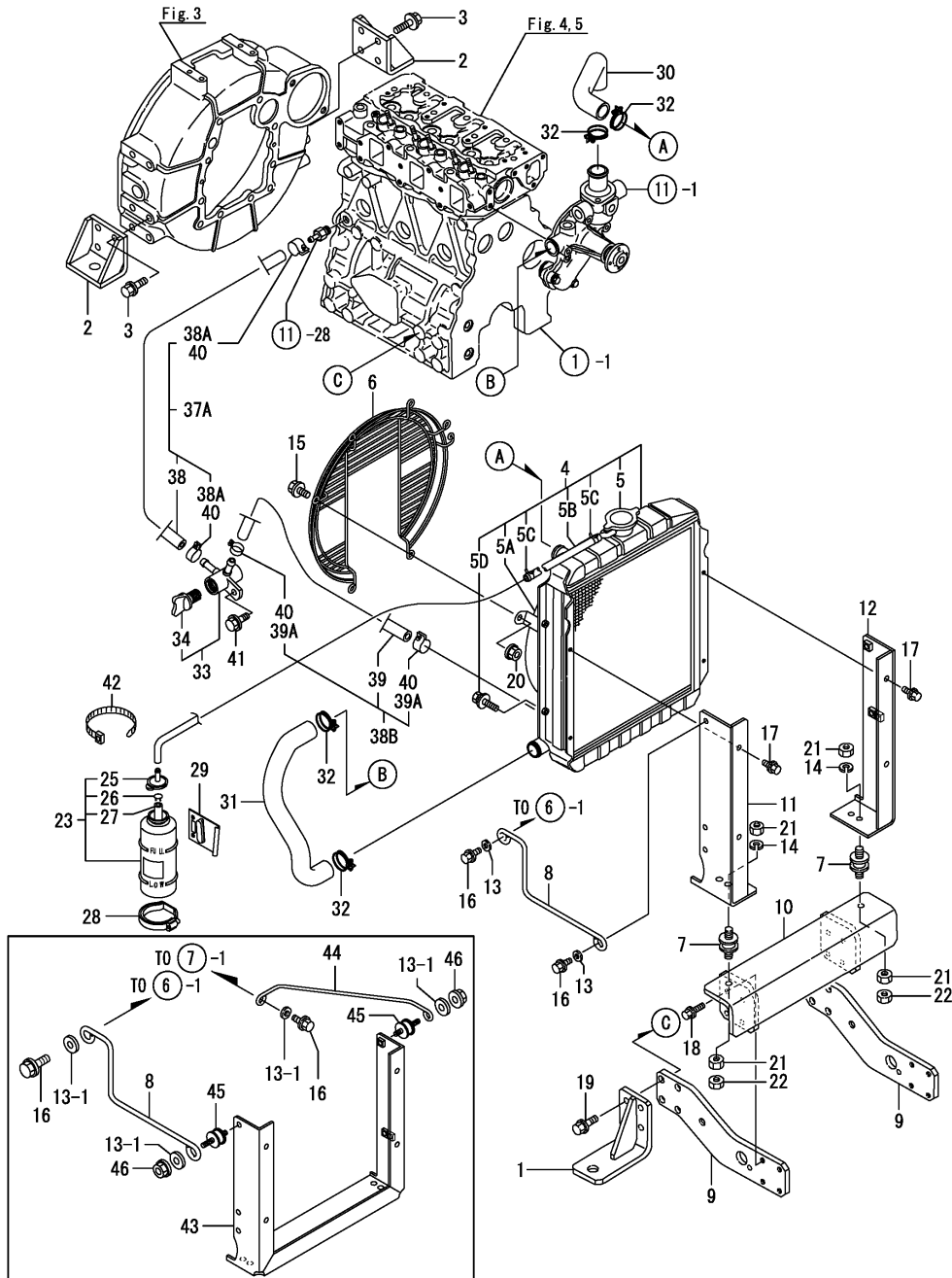

| No. | Lev. | Parts No. | Description | Q'ty | | | | | | I | R |
|-----|------|-----------------------|-------------|---------------------|-----|-----|-----|-----|-----|---|---|
| | | | | (A) | (B) | (C) | (D) | (E) | (F) | | |
| 38B | 1 | (A=EXXX) (B=EXXX) | (D=EXXX) | PIPE ASSY, DRAIN | 1 | 1 | 1 | | | W | |
| | | (A=EXXX) (B=EXXX) | (D=EXXX) | | | | | | | | |
| 39 | 2 | 121520-49160 | | PIPE, WATER DRAIN | 1 | 1 | 1 | | | | |
| 39A | 2 | 124766-59050 | | CLIP, HOSE 12 | 2 | 2 | 2 | | | W | |
| | | (A=EXXX) (B=EXXX) | (D=EXXX) | | | | | | | | |
| 40 | 1 | 124766-59050 | | CLIP, HOSE 12 | 4 | 4 | 4 | | | Z | |
| 41 | 1 | 26106-080162 | | BOLT, M8X 16 PLATED | 1 | 1 | 1 | | | | |
| | | (A=EXXX) (B=EXXX) | (D=EXXX) | | | | | | | | |
| 42 | 1 | 121750-59890 | | BAND, 140 | 1 | 1 | 1 | | | W | |
| 43 | 1 | 119822-44970 | | SUPPORT, RADIATOR | 1 | 1 | 1 | | | W | |
| | | (A=EZZZZZ) (B=EZZZZZ) | (D=EZZZZZ) | | | | | | | | |
| 44 | 1 | 119822-44950 | | RETAINER, RADIATOR | 1 | 1 | 1 | | | W | |
| 45 | 1 | 121400-44640 | | ABSORBER | 2 | 2 | 2 | | | W | |
| | | (A=EZZZZZ) (B=EZZZZZ) | (D=EZZZZZ) | | | | | | | | |
| 46 | 1 | 26366-080002 | | NUT, M8 | 2 | 2 | 2 | | | W | |
| | | (A=EZZZZZ) (B=EZZZZZ) | (D=EZZZZZ) | | | | | | | | |

(A)=3TNE78A-SA
(B)=3TNE78A-G1A
(C)=3TNE78A-G2A

(D)=3TNE78AC-G1A
(E)=
(F)=

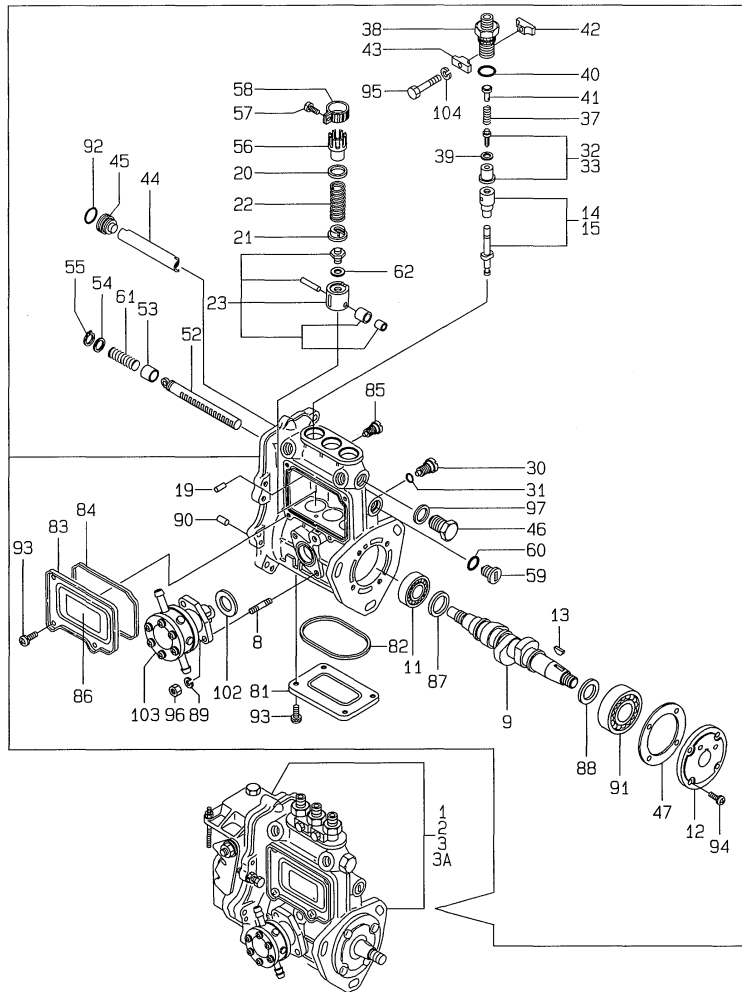

| No. | Lev. | Parts No. | Description | Q'ty | | | | | | I | R |
|-----|------|--------------|----------------------|------|-----|-----|-----|-----|-----|---|---|
| | | | | (A) | (B) | (C) | (D) | (E) | (F) | | |
| 1 | 1 | 719822-51370 | PUMP ASSY, INJECTION | 1 | | | | | | | 1 |
| 2 | 1 | 719989-51310 | PUMP ASSY, INJECTION | | 1 | | | | | | 1 |
| 3 | 1 | 719822-51400 | PUMP ASSY, INJECTION | | | 1 | | | | | 1 |
| 3A | 1 | 719822-51310 | PUMP ASSY, INJECTION | | | | | | 1 | | 1 |
| 8 | 2 | 129155-51020 | STUD | 2 | 2 | 2 | 2 | | | | |
| 9 | 2 | 119810-51040 | CAMSHAFT | 1 | 1 | 1 | 1 | | | | |
| 11 | 2 | 129155-51050 | BEARING, 17BM001D | 1 | 1 | 1 | 1 | | | | |
| 12 | 2 | 129155-51060 | SUPPORT, CAMSHAFT | 1 | 1 | 1 | 1 | | | | |
| 13 | 2 | 122710-51090 | KEY | 1 | 1 | 1 | 1 | | | | |
| 14 | 2 | 129108-51100 | PLUNGER ASSY | 3 | 3 | | 3 | | | | |
| 15 | 2 | 129411-51200 | PLUNGER ASSY | | | | 3 | | | | |
| 19 | 2 | 129155-51140 | PIN | 3 | 3 | 3 | 3 | | | | |
| 20 | 2 | 174307-51170 | RETAINER, SPRING A | 3 | 3 | 3 | 3 | | | | |
| 21 | 2 | 129155-51180 | RETAINER, SPRING | 3 | 3 | 3 | 3 | | | | |
| 22 | 2 | 124950-51190 | SPRING, PLUNGER | 3 | 3 | 3 | 3 | | | | |
| 23 | 2 | 129155-51200 | TAPPET ASSY | 3 | 3 | 3 | 3 | | | | |
| 30 | 2 | 129155-51270 | STOPPER, TAPPET | 3 | 3 | 3 | 3 | | | | |
| 31 | 2 | 129155-51280 | O-RING, S6 | 3 | 3 | 3 | 3 | | | | |
| 32 | 2 | 129100-51300 | VALVE ASSY, DELIVERY | 3 | 3 | | | | | | |
| 33 | 2 | 128170-51300 | VALVE ASSY, DELIVERY | | | | 3 | 3 | | | |
| 37 | 2 | 129155-51320 | SPRING, DELIVERY | 3 | 3 | 3 | 3 | | | | |
| 38 | 2 | 129155-51340 | RETAINER | 3 | 3 | 3 | 3 | | | | |
| 39 | 2 | 124550-51350 | GASKET, DELIVERY | 3 | 3 | 3 | 3 | | | | |
| 40 | 2 | 124550-51370 | O-RING | 3 | 3 | 3 | 3 | | | | |
| 41 | 2 | 129155-51370 | STOPPER, VALVE | 3 | 3 | 3 | 3 | | | | |
| 42 | 2 | 129155-51380 | STOPPER | 2 | 2 | 2 | 2 | | | | |
| 43 | 2 | 129155-51390 | STOPPER | 2 | 2 | 2 | 2 | | | | |
| 44 | 2 | 129155-51400 | DEFLECTOR | 1 | 1 | 1 | 1 | | | | |
| 45 | 2 | 129155-51410 | BOLT | 1 | 1 | 1 | 1 | | | | |
| 46 | 2 | 129155-51420 | PLUG, M16 | 1 | 1 | 1 | 1 | | | | |
| 47 | 2 | 129155-51450 | SHIM SET, ADJUSTING | 1 | 1 | 1 | 1 | | | | |
| 52 | 2 | 129155-51500 | RACK, CONTROL | 1 | 1 | 1 | 1 | | | | |
| 53 | 2 | 129155-51521 | BUSH, RACK | 1 | 1 | 1 | 1 | | | | |
| 54 | 2 | 129155-51530 | SPACER | 1 | 1 | 1 | 1 | | | | |
| 55 | 2 | 129155-51540 | CIRCLIP | 1 | 1 | 1 | 1 | | | | |
| 56 | 2 | 129155-51550 | PINION, CONTROL | 3 | 3 | 3 | 3 | | | | |
| 57 | 2 | 122117-51560 | SCREW | 3 | 3 | 3 | 3 | | | | |
| 58 | 2 | 174307-51560 | PINION | 3 | 3 | 3 | 3 | | | | |
| 59 | 2 | 129155-51570 | PLUG, M12 | 1 | 1 | 1 | 1 | | | | |
| 60 | 2 | 129155-51580 | O-RING | 1 | 1 | 1 | 1 | | | | |
| 61 | 2 | 129155-51591 | SPRING, RACK | 1 | 1 | 1 | 1 | | | | |
| 62 | 2 | 129155-51600 | SHIM SET, ADJUSTING | 3 | 3 | 3 | 3 | | | | |
| 81 | 2 | 129155-51700 | COVER | 1 | 1 | 1 | 1 | | | | |
| 82 | 2 | 129155-51710 | GASKET | 1 | 1 | 1 | 1 | | | | |
| 83 | 2 | 129155-51750 | COVER | 1 | 1 | 1 | 1 | | | | |
| 84 | 2 | 129155-51760 | GASKET | 1 | 1 | 1 | 1 | | | | |
| 85 | 2 | 129155-51790 | STOOPER, RACK | 1 | 1 | 1 | 1 | | | | |
| 86 | 2 | 129156-51910 | LABEL, CAUTION | 1 | 1 | 1 | 1 | | | | |
| 87 | 2 | 129155-51930 | SPACER, T=3.25 | 1 | 1 | 1 | 1 | | | | |
| 88 | 2 | 129155-51940 | SPACER, T=1.5 | 1 | 1 | 1 | 1 | | | | |
| 89 | 2 | 22217-060000 | WASHER, SPRING 6 | 2 | 2 | 2 | 2 | | | | |

Remarks
(1) GOVERNOR(FIG.14) IS INCORPORATED
IN THIS FUEL INJECTION PUMP ASSY
(REF.NO.1,2,3,3A).

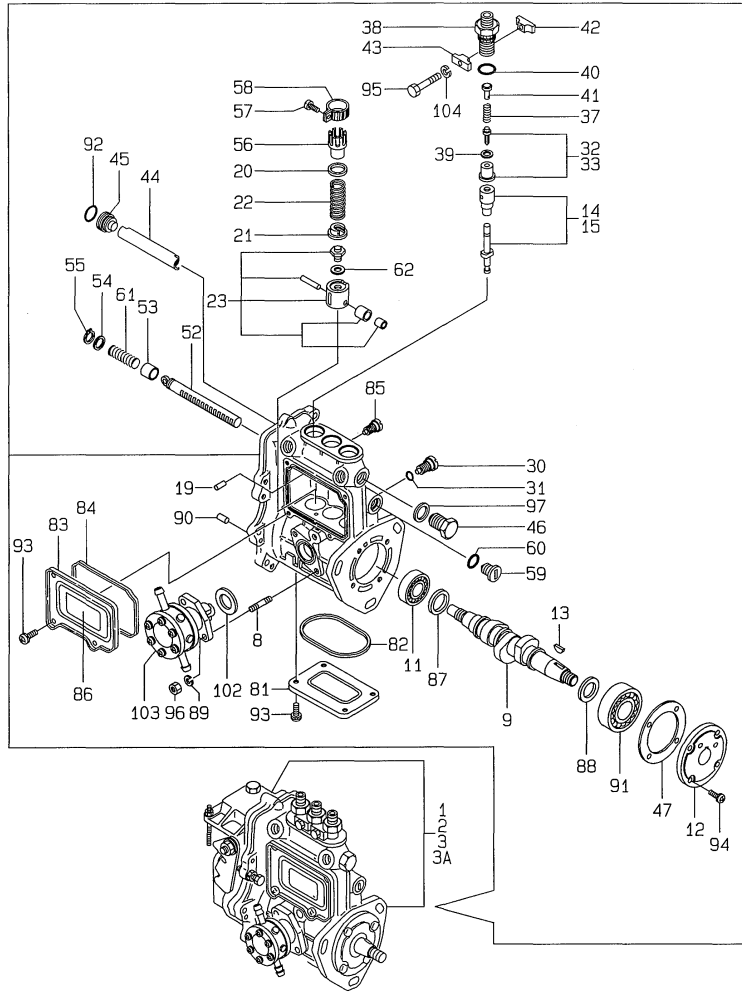

(A)=3TNE78A-SA
(B)=3TNE78A-G1A
(C)=3TNE78A-G2A

(D)=3TNE78AC-G1A
(E)=
(F)=

| No. | Lev. | Parts No. | Description | Q'ty | | | | | | I | R |
|-----|------|--------------|----------------------|------|-----|-----|-----|-----|-----|---|---|
| | | | | (A) | (B) | (C) | (D) | (E) | (F) | | |
| 90 | 2 | 22351-050010 | PIN, SPRING 5.0X10 | 2 | 2 | 2 | 2 | | | | |
| 91 | 2 | 24101-063034 | BEARING, BALL 6303 | 1 | 1 | 1 | 1 | | | | |
| 92 | 2 | 24341-000160 | O-RING, 1AS16.0 | 1 | 1 | 1 | 1 | | | | |
| 93 | 2 | 26022-050102 | SCREW, M5X10 | 8 | 8 | 8 | 8 | | | | |
| 94 | 2 | 26022-060162 | SCREW, M6X16 | 4 | 4 | 4 | 4 | | | | |
| 95 | 2 | 26116-050302 | BOLT, M5X 30 PLATED | 2 | 2 | 2 | 2 | | | | |
| 96 | 2 | 26716-060002 | NUT, M6 | 2 | 2 | 2 | 2 | | | | |
| 97 | 2 | 22190-160002 | WASHER, SEAL 16 | 1 | 1 | 1 | 1 | | | | |
| 102 | 2 | 129155-52050 | GASKET | 1 | 1 | 1 | 1 | | | | |
| 103 | 2 | 129100-52100 | PUMP ASSY, FUEL FEED | 1 | 1 | 1 | 1 | | | | |
| 104 | 2 | 22217-050000 | WASHER, SPRING 5 | 2 | 2 | 2 | 2 | | | | |



Remarks
(1) GOVERNOR(FIG.14) IS INCORPORATED
IN THIS FUEL INJECTION PUMP ASSY
(REF.NO.1,2,3,3A).

(A)=3TNE78A-SA
(B)=3TNE78A-G1A
(C)=3TNE78A-G2A

(D)=3TNE78AC-G1A
(E)=
(F)=

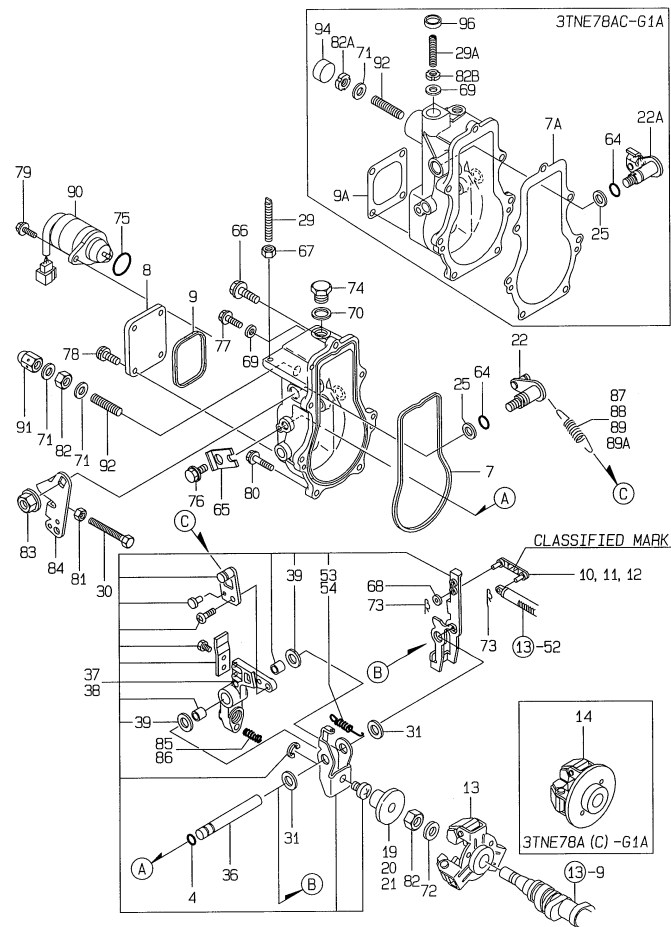

| No. | Lev. | Parts No. | Description | Q'ty | | | | | | I | R |
|------|------|---|----------------------|------|-----|-----|-----|-----|-----|---|---|
| | | | | (A) | (B) | (C) | (D) | (E) | (F) | | |
| 4 | 2 | 129155-51280 | O-RING, S6 | 1 | 1 | 1 | 1 | | | | |
| 7 | 2 | 129052-61050 | GASKET | 1 | 1 | 1 | | | | | |
| 7A | 2 | 129116-61051 | GASKET | | | | 1 | | | | |
| 8 | 2 | 129052-61060 | COVER, GOVERNOR CASE | 1 | 1 | 1 | 1 | | | | |
| 9 | 2 | 129052-61070 | GASKET | 1 | 1 | 1 | | | | | |
| 9A | 2 | 119988-61070 | GASKET | | | | 1 | | | | |
| 10 | 2 | 129155-61120 | LINK, L=30 MARK 0 | 1 | 1 | 1 | 1 | | | | 1 |
| 11 | 2 | 129155-61130 | LINK, L=31 MARK 1 | 1 | 1 | 1 | 1 | | | | 1 |
| 12 | 2 | 129155-61140 | LINK, L=30.5 MARK 05 | 1 | 1 | 1 | 1 | | | | 1 |
| 13 | 2 | 129155-61201 | WEIGHT ASSY,GOVERNOR | 1 | | 1 | | | | | |
| 14 | 2 | 171488-61200 | WEIGHT ASSY,GOVERNOR | | 1 | | 1 | | | | |
| 19 | 2 | 129155-61341 | SLEEVE | 1 | 1 | 1 | 1 | | | | 2 |
| 20 | 2 | 129155-61350 | SLEEVE, L=24.9 | 1 | 1 | 1 | 1 | | | | 2 |
| 21 | 2 | 129155-61360 | SLEEVE, L=25.2 | 1 | 1 | 1 | 1 | | | | 2 |
| 22 | 2 | 129100-61400 | SHAFT ASSY | 1 | 1 | 1 | | | | | |
| 22A | 2 | 119988-61400 | SHAFT ASSY | | | | | | | | 1 |
| 25 | 2 | 129155-61430 | SPACER | 1 | 1 | 1 | 1 | | | | |
| 29 | 2 | 129155-61450 | BOLT, LIMITER | 1 | 1 | 1 | | | | | |
| 29A | 2 | 119988-61460 | BOLT, LIMITER | | | | | | | | 1 |
| 30 | 2 | 129155-61460 | BOLT, IDLE | 1 | 1 | 1 | 1 | | | | |
| 31 | 2 | 129155-61480 | SPACER ASSY | 2 | 2 | 2 | 2 | | | | |
| 36 | 2 | 129052-61390 | SHAFT | 1 | 1 | 1 | 1 | | | | |
| 37 | 2 | 129052-61500 | LEVER ASSY, GOVERNOR | 1 | | | | | | | |
| 38 | 2 | 129412-61500 | LEVER ASSY, GOVERNOR | | 1 | 1 | 1 | | | | |
| 39 | 3 | 174307-51700 | SHIM SET | 2 | 2 | 2 | 2 | | | | |
| 53 | 3 | 129052-61540 | SPRING, SET | 1 | | | | | | | |
| 54 | 3 | 119843-61540 | SPRING, SET | | 1 | 1 | 1 | | | | |
| 64 | 2 | 129155-61830 | O-RING, S10 | 1 | 1 | 1 | 1 | | | | |
| 65 | 2 | 119660-61901 | RETAINER, SHAFT | 1 | 1 | 1 | 1 | | | | |
| 66 | 2 | 129155-61950 | BOLT | 1 | 1 | 1 | 1 | | | | |
| 67 | 2 | 124550-66370 | NUT, M6 | 1 | 1 | 1 | | | | | |
| 68 | 2 | 22117-040000 | WASHER, 4 | 1 | 1 | 1 | 1 | | | | |
| 69 | 2 | 22190-060002 | WASHER, SEAL 6 | 1 | 1 | 1 | 1 | | | | |
| 69-1 | 2 | 22190-060003 | SEAL WASER 6 | 1 | 1 | 1 | | | | | N |
| | | (A=EXXXX) (B=EXXXX) (C=EXXXX) | | | | | | | | | |
| 70 | 2 | 22190-100002 | WASHER, SEAL 10 | 1 | 1 | 1 | 1 | | | | |
| 71 | 2 | 22190-120002 | WASHER, SEAL 12 | 2 | 2 | 2 | 1 | | | | |
| 72 | 2 | 22287-120000 | WASHER, 12 | 1 | 1 | 1 | 1 | | | | |
| 73 | 2 | 22372-040000 | PIN, SNAP 4 | 2 | 2 | 2 | 2 | | | | |
| 74 | 2 | 23887-100002 | PLUG, 10 | 1 | 1 | 1 | 1 | | | | |
| 75 | 2 | 24341-000280 | O-RING, 1AS28.0 | 1 | 1 | 1 | 1 | | | | |
| 75-1 | 2 | 158552-61900 | O-RING | 1 | 1 | 1 | 1 | | | | N |
| | | (A=EXXXXX) (B=EXXXXX) (C=EXXXXX) (D=EXXXXX) | | | | | | | | | |
| 76 | 2 | 26106-060102 | BOLT, M6X 10 PLATED | 1 | 1 | 1 | 1 | | | | |
| 77 | 2 | 26106-060102 | BOLT, M6X 10 PLATED | 1 | 1 | 1 | | | | | |
| 78 | 2 | 26106-060102 | BOLT, M6X 10 PLATED | 4 | 4 | 4 | 4 | | | | |
| 79 | 2 | 26106-060142 | BOLT, M6X 14 PLATED | 2 | 2 | 2 | 2 | | | | |
| 80 | 2 | 26106-060202 | BOLT, M6X 20 PLATED | 6 | 6 | 6 | 6 | | | | |
| 81 | 2 | 26756-060002 | NUT, LOCK M6 | 1 | 1 | 1 | 1 | | | | |
| 82 | 2 | 26776-120002 | NUT, LOCK M12 | 2 | 2 | 2 | 1 | | | | |
| 82A | 2 | 119685-61940 | NUT, M12 | | | | 1 | | | | |

Remarks

(1) SELECTIVE PARTS: CERTAIN THE CLASSIFICATION MARK, THEN PLACE YOUR ORDER.(REFER TO ILLUSTRATION).

(2) SELECTIVE PARTS.

(3) REPAIR PART.

* THIS FIGURE(GOVERNOR ASSY) IS INCORPORATED IN THE FUEL INJECTION PUMP ASSY(FIG.13).

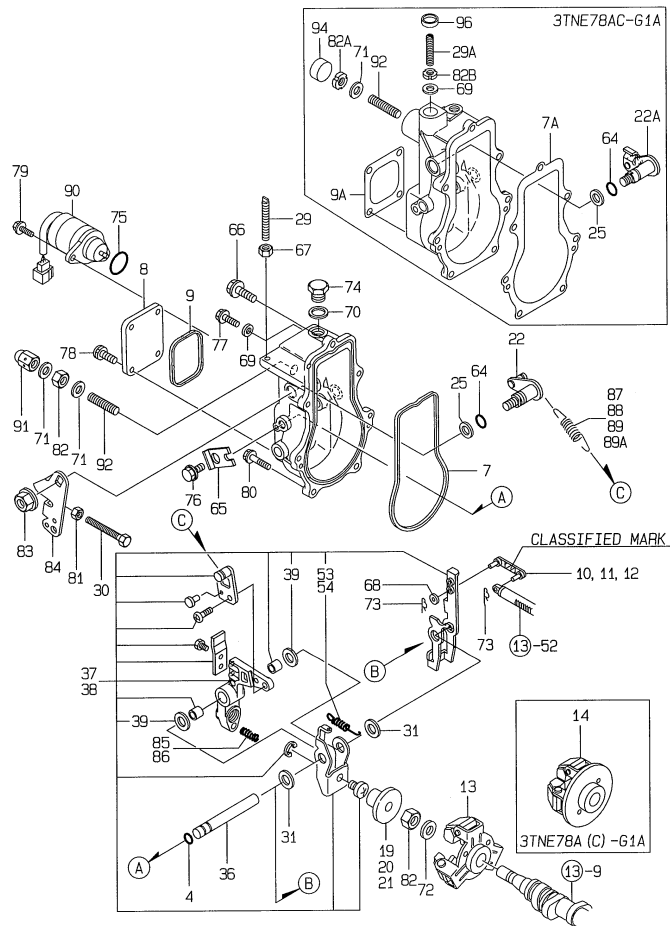

(A)=3TNE78A-SA
(B)=3TNE78A-G1A
(C)=3TNE78A-G2A

(D)=3TNE78AC-G1A
(E)=
(F)=

| No. | Lev. | Parts No. | Description | Q'ty | | | | | | I | R | |
|------|------|----------------------------|----------------------|------|-----|-----|-----|-----|-----|---|---|---|
| | | | | (A) | (B) | (C) | (D) | (E) | (F) | | | |
| 82B | 2 | 119685-61950 | NUT, M6 | | | | | | | | | |
| 83 | 2 | 26366-080002 | NUT, M8 | 1 | 1 | 1 | 1 | | | | | |
| 84 | 2 | 129100-61440 | LEVER, CONTROL | 1 | 1 | 1 | | | | | | |
| 84-1 | 2 | 171488-61440 (B=E15302) | LEVER, CONTROL | | 1 | | 1 | | | | | N |
| 85 | 2 | 129100-61650 | SPRING, CONTROLLER | 1 | | | | | | | | |
| 86 | 2 | 129500-61650 | SPRING, FUEL CONTROL | | 1 | 1 | 1 | | | | | |
| 87 | 2 | 171353-61700 | SPRING, GOVERNOR | 1 | | | | | | | | |
| 88 | 2 | 129477-61720 | SPRING, GOVERNOR | | 1 | | | | | | | |
| 89 | 2 | 129500-61700 | SPRING, GOVERNOR | | | | 1 | | | | | |
| 89A | 2 | 129477-61710 | SPRING, GOVERNOR | | | | | | | 1 | | |
| 90 | 2 | 119653-77950 | SOLENOID, STOP | 1 | 1 | 1 | 1 | | | | | |
| 91 | 2 | 26687-120002 | NUT, CAP M12 | 1 | 1 | 1 | | | | | | |
| 92 | 2 | 129155-61470 | BOLT, CONTROL | 1 | 1 | 1 | 1 | | | | | |
| 94 | 1 | 119621-66610 | PLUG, 22 | | | | | | | 1 | | 3 |
| 96 | 1 | 119621-66710 | PLUG, 14 | | | | | | | 1 | | 3 |

Remarks

(1) SELECTIVE PARTS: CERTAIN THE CLASSIFICATION MARK, THEN PLACE YOUR ORDER.(REFER TO ILLUSTRATION)

(2) SELECTIVE PARTS.

(3) REPAIR PART.

* THIS FIGURE(GOVERNOR ASSY) IS INCORPORATED IN THE FUEL INJECTION PUMP ASSY(FIG.13).

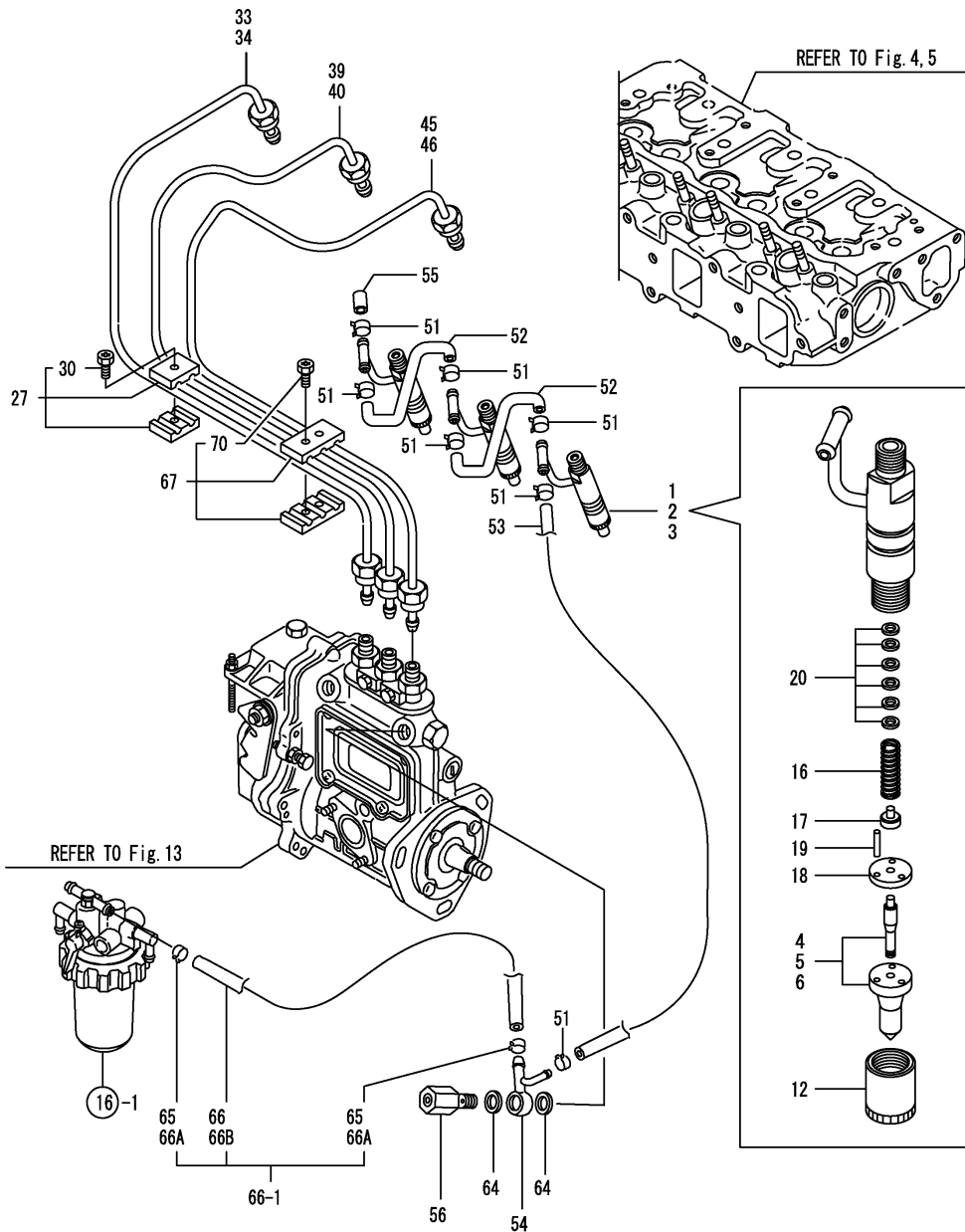

(A)=3TNE78A-SA
(B)=3TNE78A-G1A
(C)=3TNE78A-G2A

(D)=3TNE78AC-G1A
(E)=
(F)=

| No. | Lev. | Parts No. | Description | Q'ty | | | | | | I | R |
|------|------|--------------|----------------------|------------|------------|-----|-----|-----|-----|---|---|
| | | | | (A) | (B) | (C) | (D) | (E) | (F) | | |
| 1 | 1 | 729500-53200 | VALVE ASSY,INJECTION | 3 | | | | | | | |
| 2 | 1 | 719818-53100 | VALVE ASSY,INJECTION | | 3 | | 3 | | | | |
| 3 | 1 | 729102-53100 | VALVE ASSY,INJECTION | | | 3 | | | | | |
| 4 | 2 | 129500-53050 | VALVE ASSY,INJECTION | 3 | | | | | | | |
| 5 | 2 | 119818-53000 | VALVE ASSY,INJECTION | | 3 | | 3 | | | | |
| 6 | 2 | 129102-53000 | VALVE ASSY,INJECTION | | | 3 | | | | | |
| 12 | 2 | 114250-53080 | NUT, NOZZLE D16.95 | 3 | 3 | 3 | 3 | | | | |
| 16 | 2 | 114250-53120 | SPRING, NOZZLE | 3 | 3 | 3 | 3 | | | | |
| 17 | 2 | 114250-53130 | SEAT, SPRING | 3 | 3 | 3 | 3 | | | | |
| 18 | 2 | 114250-53140 | PLATE | 3 | 3 | 3 | 3 | | | | |
| 19 | 2 | 114250-53210 | PIN | 6 | 6 | 6 | 6 | | | | |
| 20 | 2 | 114250-53400 | SHIM SET | 3 | 3 | 3 | 3 | | | | |
| 27 | 1 | 119305-59120 | RETAINER, PIPE | 1 | 1 | | 1 | | | | |
| 30 | 2 | 129150-59131 | BOLT, M4X14 | 1 | 1 | | 1 | | | | |
| 33 | 1 | 119813-59811 | PIPE ASSY, INJECTION | 1 | 1 | | 1 | | | | |
| 33-1 | 1 | 119813-59812 | PIPE ASSY, INJECTION | 1 | 1 | | 1 | | | | R |
| | | (A=E14921) | (B=E14920) | (D=E01893) | | | | | | | |
| 34 | 1 | 119811-59810 | PIPE ASSY, INJECTION | | | | 1 | | | | |
| 39 | 1 | 119813-59821 | PIPE ASSY, INJECTION | 1 | 1 | | 1 | | | | |
| 40 | 1 | 119811-59820 | PIPE ASSY, INJECTION | | | | 1 | | | | |
| 45 | 1 | 119813-59831 | PIPE ASSY, INJECTION | 1 | 1 | | 1 | | | | |
| 46 | 1 | 119811-59830 | PIPE ASSY, INJECTION | | | | 1 | | | | |
| 51 | 1 | 124066-59100 | CLIP, HOSE 8 | 7 | 7 | 7 | 7 | | | | |
| 52 | 1 | 121250-59550 | PIPE, FUEL D8X120 | 2 | 2 | 2 | 2 | | | | |
| 53 | 1 | 119840-59560 | PIPE, FUEL RETURN | 1 | 1 | 1 | 1 | | | | |
| 54 | 1 | 119840-59570 | JOINT | 1 | 1 | 1 | 1 | | | | |
| 55 | 1 | 129150-59580 | CAP | 1 | 1 | 1 | 1 | | | | |
| 56 | 1 | 129100-59951 | VALVE ASSY, CHECK | 1 | 1 | 1 | 1 | | | | |
| 64 | 1 | 23414-120000 | GASKET, 12X1.0 | 2 | 2 | 2 | 2 | | | | |
| 65 | 1 | 124766-59050 | CLIP, HOSE 12 | 2 | 2 | 2 | 2 | | | | Z |
| | | (A=E14921) | (B=E14920) | (C=E14922) | (D=E01893) | | | | | | |
| 66 | 1 | 129255-59580 | PIPE, FUEL | 1 | 1 | 1 | 1 | | | | |
| 66-1 | 1 | 129210-59130 | PIPE ASSY, FUEL | 1 | 1 | 1 | 1 | | | | N |
| | | (A=E14921) | (B=E14920) | (C=E14922) | (D=E01893) | | | | | | |
| 66A | 2 | 124766-59050 | CLIP, HOSE 12 | 2 | 2 | 2 | 2 | | | | W |
| | | (A=E14921) | (B=E14920) | (C=E14922) | (D=E01893) | | | | | | |
| 66B | 2 | 105025-59750 | PIPE, FUEL | 1 | 1 | 1 | 1 | | | | W |
| | | (A=E14921) | (B=E14920) | (C=E14922) | (D=E01893) | | | | | | |
| 67 | 1 | 129150-59120 | RETAINER, PIPE | 1 | 1 | 1 | 1 | | | | |
| 70 | 2 | 129150-59131 | BOLT, M4X14 | 2 | 2 | 2 | 2 | | | | |

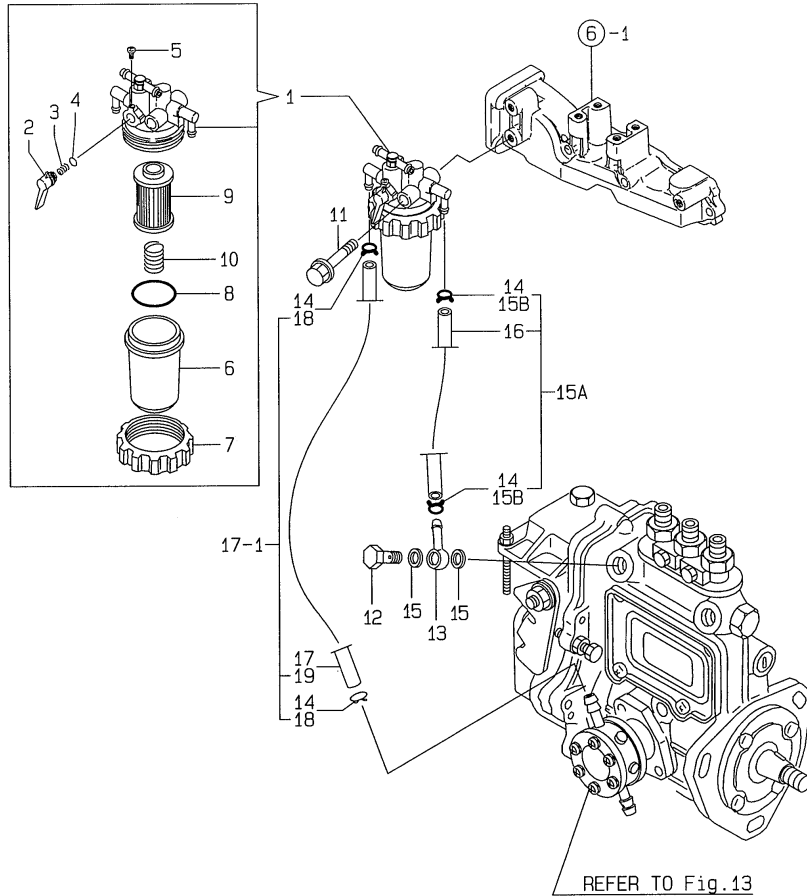

(A)=3TNE78A-SA
(B)=3TNE78A-G1A
(C)=3TNE78A-G2A

(D)=3TNE78AC-G1A
(E)=
(F)=

| No. | Lev. | Parts No. | Description | Q'ty | | | | | | I | R |
|------|------|--------------|-------------------|------------|------------|-----|-----|-----|-----|---|---|
| | | | | (A) | (B) | (C) | (D) | (E) | (F) | | |
| 1 | 1 | 119833-55620 | FILTER ASSY, FUEL | 1 | 1 | 1 | 1 | | | | |
| 2 | 2 | 119810-55340 | LEVER | 1 | 1 | 1 | 1 | | | | |
| 3 | 2 | 104200-55330 | SPRING, VALVE | 1 | 1 | 1 | 1 | | | | |
| 4 | 2 | 24311-240100 | O-RING, 1AP10A | 1 | 1 | 1 | 1 | | | | |
| 5 | 2 | 104200-55750 | SCREW, M4 | 1 | 1 | 1 | 1 | | | | |
| 6 | 2 | 121254-55510 | COVER | 1 | 1 | 1 | 1 | | | | |
| 7 | 2 | 110250-55610 | RING, RETAINING | 1 | 1 | 1 | 1 | | | | |
| 8 | 2 | 102103-55520 | O-RING | 1 | 1 | 1 | 1 | | | | |
| 9 | 2 | 119810-55650 | ELEMENT | 1 | 1 | 1 | 1 | | | | |
| 10 | 2 | 121250-55620 | SPRING | 1 | 1 | 1 | 1 | | | | |
| 11 | 1 | 26014-080702 | BOLT, M8X 70 | 1 | 1 | 1 | 1 | | | | |
| 12 | 1 | 103854-39140 | BOLT, PIPE JOINT | 1 | 1 | 1 | 1 | | | | |
| 13 | 1 | 101304-59020 | JOINT, PIPE 12 | 1 | 1 | 1 | 1 | | | | |
| 14 | 1 | 124766-59050 | CLIP, HOSE 12 | 4 | 4 | 4 | 4 | | | | Z |
| | | (A=E14921) | (B=E14920) | (C=E14922) | (D=E01893) | | | | | | |
| 15 | 1 | 104200-59170 | GASKET, 12 | 2 | 2 | 2 | 2 | | | | |
| 15-1 | 1 | 22190-120002 | WASHER, SEAL 12 | 2 | 2 | 2 | 2 | | | | N |
| | | (A=E10184) | (B=E10615) | (C=E10201) | (D=E00973) | | | | | | |
| 15A | 1 | 129210-59040 | PIPE ASSY, FUEL | 1 | 1 | 1 | 1 | | | | W |
| | | (A=E14921) | (B=E14920) | (C=E14922) | (D=E01893) | | | | | | |
| 15B | 2 | 124766-59050 | CLIP, HOSE 12 | 2 | 2 | 2 | 2 | | | | W |
| | | (A=E14921) | (B=E14920) | (C=E14922) | (D=E01893) | | | | | | |
| 16 | 2 | 129555-59510 | PIPE, D13/7.5X180 | 1 | 1 | 1 | 1 | | | | |
| 17 | 1 | 129255-59580 | PIPE, FUEL | 1 | 1 | 1 | 1 | | | | |
| 17-1 | 1 | 129210-59130 | PIPE ASSY, FUEL | 1 | 1 | 1 | 1 | | | | N |
| | | (A=E14921) | (B=E14920) | (C=E14922) | (D=E01893) | | | | | | |
| 18 | 2 | 124766-59050 | CLIP, HOSE 12 | 2 | 2 | 2 | 2 | | | | W |
| | | (A=E14921) | (B=E14920) | (C=E14922) | (D=E01893) | | | | | | |
| 19 | 2 | 105025-59750 | PIPE, FUEL | 1 | 1 | 1 | 1 | | | | W |
| | | (A=E14921) | (B=E14920) | (C=E14922) | (D=E01893) | | | | | | |

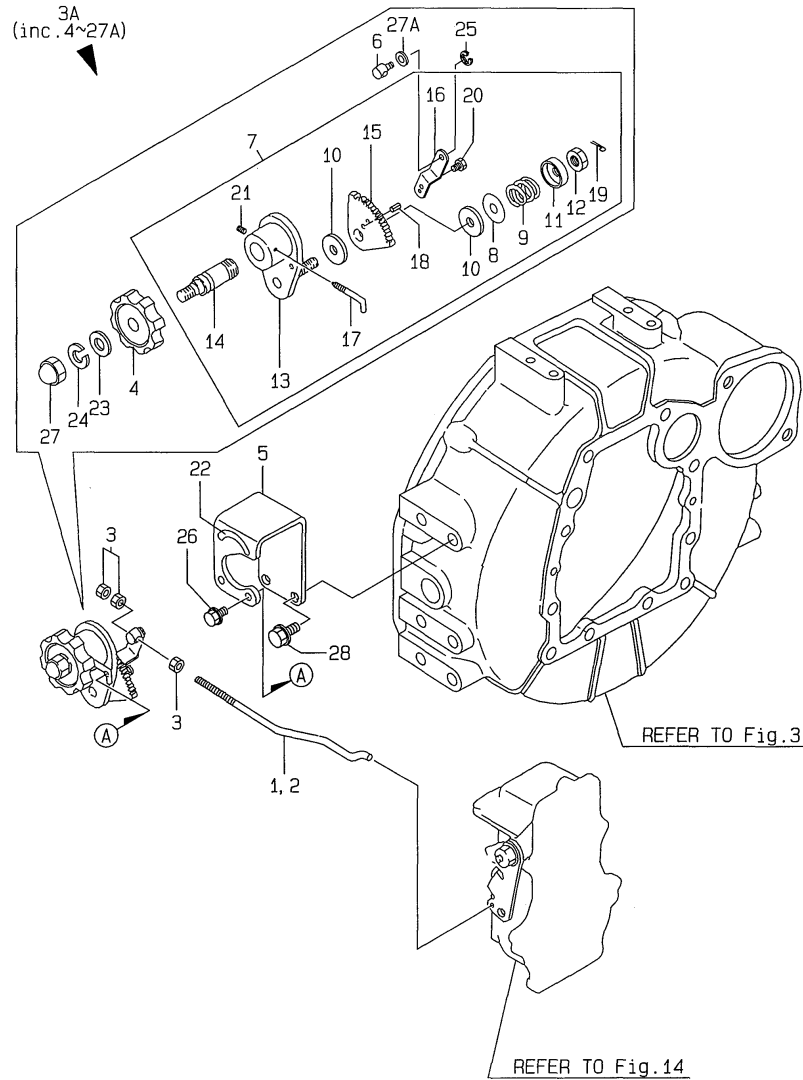

(A)=3TNE78A-SA
(B)=3TNE78A-G1A
(C)=3TNE78A-G2A

(D)=3TNE78AC-G1A
(E)=
(F)=

| No. | Lev. | Parts No. | Description | Qty | | | | | | I | R |
|------|------|--------------|----------------------|------------|------------|-----|-----|-----|-----|---|---|
| | | | | (A) | (B) | (C) | (D) | (E) | (F) | | |
| 1 | 1 | 119888-66120 | LINK, ENGINE CONTROL | 1 | | 1 | | | | | |
| 2 | 1 | 119888-66150 | LINK | | 1 | | | 1 | | | |
| 3 | 1 | 26756-050002 | NUT, LOCK M5 | 3 | 3 | 3 | 3 | | | | |
| 3A | 1 | 119888-66160 | CONTROLLER ASSY | 1 | 1 | 1 | 1 | | | | W |
| | | (A=E15122) | (B=E15156) | (C=E15132) | (D=E01893) | | | | | | |
| 4 | 2 | 126650-66020 | HANDLE, REGULATOR | 1 | 1 | 1 | 1 | | | | |
| 5 | 2 | 119888-66110 | BRACKET | 1 | 1 | 1 | 1 | | | | |
| 6 | 2 | 119888-66130 | PIVOT | 1 | 1 | 1 | 1 | | | | |
| 7 | 2 | 171048-67010 | CONTROLLER ASSY | 1 | 1 | 1 | 1 | | | | |
| 8 | 3 | 171102-66080 | WASHER | 1 | 1 | 1 | 1 | | | | |
| 9 | 3 | 104200-66820 | SPRING | 1 | 1 | 1 | 1 | | | | |
| 10 | 3 | 104200-66830 | PLATE, FRICTION | 2 | 2 | 2 | 2 | | | | |
| 11 | 3 | 104200-66850 | WASHER | 1 | 1 | 1 | 1 | | | | |
| 12 | 3 | 104200-66860 | NUT | 1 | 1 | 1 | 1 | | | | |
| 13 | 3 | 171085-67100 | BRACKET | 1 | 1 | 1 | 1 | | | | |
| 14 | 3 | 171085-67110 | SHAFT, DRIVE | 1 | 1 | 1 | 1 | | | | |
| 15 | 3 | 171085-67120 | GEAR | 1 | 1 | 1 | 1 | | | | |
| 16 | 3 | 171048-67130 | LEVER | 1 | 1 | 1 | 1 | | | | |
| 17 | 3 | 171048-67140 | STOPPER | 1 | 1 | 1 | 1 | | | | |
| 18 | 3 | 22351-020006 | PIN, SPRING 2.0X 6 | 1 | 1 | 1 | 1 | | | | |
| 19 | 3 | 22411-200150 | COTTER PIN | 1 | 1 | 1 | 1 | | | | |
| 20 | 3 | 26116-060082 | BOLT, M6X 8 PLATED | 1 | 1 | 1 | 1 | | | | |
| 21 | 3 | 26921-050122 | SCREW, M5X12 | 1 | 1 | 1 | 1 | | | | |
| 22 | 2 | 170064-67210 | LABEL, HANDLE | 1 | 1 | 1 | 1 | | | | |
| 23 | 2 | 22117-100000 | WASHER, 10 | 1 | 1 | 1 | 1 | | | | |
| 23-1 | 2 | 22137-100000 | WASHER, 10 | 1 | 1 | 1 | 1 | | | | N |
| | | (A=E15122) | (B=E15156) | (C=E15132) | (D=E01893) | | | | | | |
| 24 | 2 | 22217-100000 | WASHER, SPRING 10 | 1 | 1 | 1 | 1 | | | | |
| 25 | 2 | 22272-000050 | RING, E- 5 | 1 | 1 | 1 | 1 | | | | |
| 26 | 2 | 26106-060102 | BOLT, M6X 10 PLATED | 2 | 2 | 2 | 2 | | | | |
| 27 | 2 | 26657-100002 | NUT, CAP M10 | 1 | 1 | 1 | 1 | | | | |
| 27A | 2 | 22117-060000 | WASHER, 6 | 1 | 1 | 1 | 1 | | | | W |
| | | (A=E15122) | (B=E15156) | (C=E15132) | (D=E01893) | | | | | | |
| 28 | 1 | 26106-080162 | BOLT, M8X 16 PLATED | 2 | 2 | 2 | 2 | | | | |

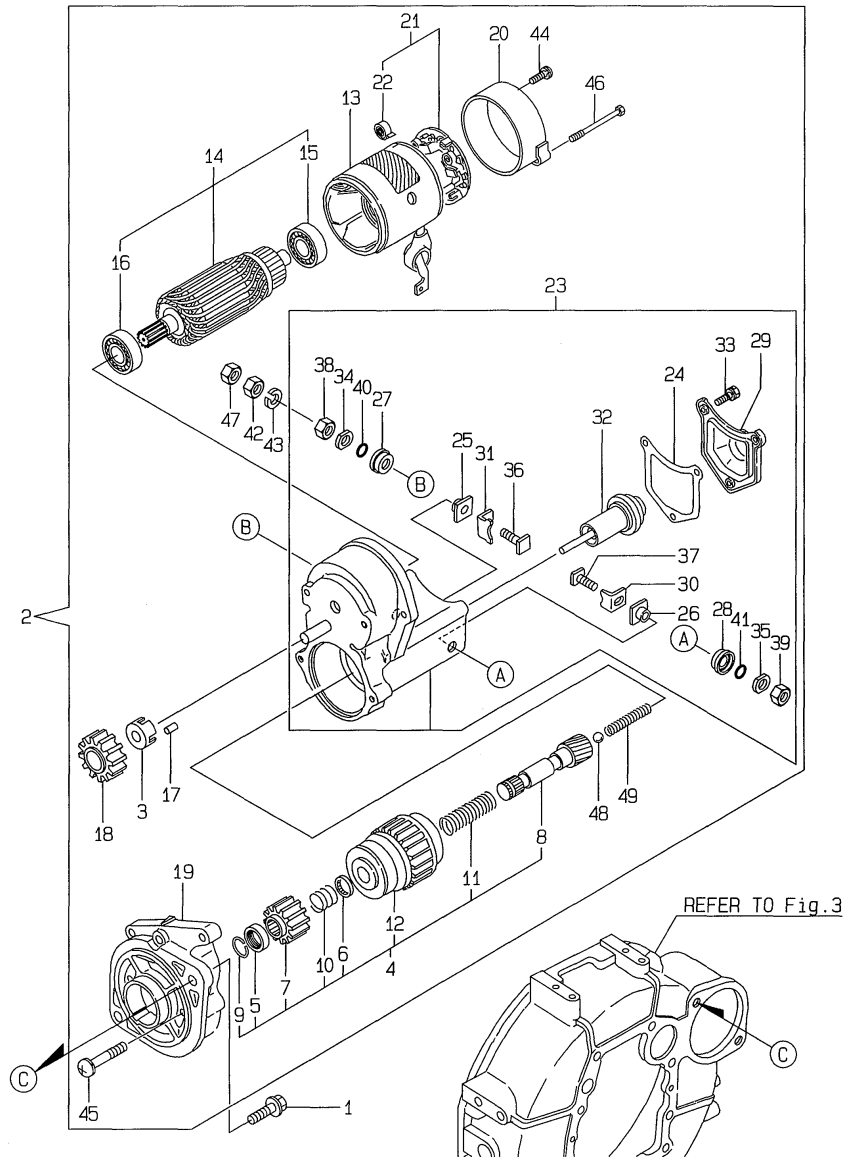

(A)=3TNE78A-SA
(B)=3TNE78A-G1A
(C)=3TNE78A-G2A

(D)=3TNE78AC-G1A
(E)=
(F)=

| No. | Lev. | Parts No. | Description | Q'ty | | | | | | I | R |
|-----|------|--------------|----------------------|------|-----|-----|-----|-----|-----|---|---|
| | | | | (A) | (B) | (C) | (D) | (E) | (F) | | |
| 1 | 1 | 26116-120252 | BOLT, M12X 25 PLATED | 2 | 2 | 2 | 2 | | | | |
| 2 | 1 | 124520-77011 | STARTER | 1 | 1 | 1 | 1 | | | | |
| 3 | 2 | X0280630011 | RETAINER | 1 | 1 | 1 | 1 | | | | |
| 4 | 2 | X0280992761 | CLUTCH KIT | 1 | 1 | 1 | 1 | | | | |
| 5 | 3 | X0280210230 | NUT | 1 | 1 | 1 | 1 | | | | |
| 6 | 3 | X0283270140 | RETAINER | 1 | 1 | 1 | 1 | | | | |
| 7 | 3 | X0283712350 | PINION, STARTER | 1 | 1 | 1 | 1 | | | | |
| 8 | 3 | X0283810040 | SHAFT | 1 | 1 | 1 | 1 | | | | |
| 9 | 3 | X9490721080 | RING | 1 | 1 | 1 | 1 | | | | |
| 10 | 3 | X9491703371 | SPRING, COIL | 1 | 1 | 1 | 1 | | | | |
| 11 | 3 | X9491704260 | SPRING | 1 | 1 | 1 | 1 | | | | |
| 12 | 3 | 121120-77930 | CASE ASSY, STARTER | 1 | 1 | 1 | 1 | | | | |
| 13 | 2 | X0281003751 | YOKE ASSY | 1 | 1 | 1 | 1 | | | | |
| 14 | 2 | X0282001531 | ARMATURE ASSY | 1 | 1 | 1 | 1 | | | | |
| 15 | 3 | X9491001360 | BEARING | 1 | 1 | 1 | 1 | | | | |
| 16 | 3 | X9491001860 | BEARING, BALL | 1 | 1 | 1 | 1 | | | | |
| 17 | 2 | X0283060061 | ROLLER | 5 | 5 | 5 | 5 | | | | |
| 18 | 2 | X0283711420 | PINION | 1 | 1 | 1 | 1 | | | | |
| 19 | 2 | X0284004910 | HOUSING | 1 | 1 | 1 | 1 | | | | |
| 20 | 2 | X0285040631 | FRAME ASSY | 1 | 1 | 1 | 1 | | | | |
| 21 | 2 | X0285100460 | HOLDER ASSY, BRUSH | 1 | 1 | 1 | 1 | | | | |
| 22 | 3 | X9491730461 | SPRING | 4 | 4 | 4 | 4 | | | | |
| 23 | 2 | X0534006460 | SWITCH | 1 | 1 | 1 | 1 | | | | |
| 24 | 3 | X0534040320 | GASKET | 1 | 1 | 1 | 1 | | | | |
| 25 | 3 | X0534490120 | BUSH | 1 | 1 | 1 | 1 | | | | |
| 26 | 3 | X0534490120 | BUSH | 1 | 1 | 1 | 1 | | | | |
| 27 | 3 | X0534490230 | BUSH | 1 | 1 | 1 | 1 | | | | |
| 28 | 3 | X0534490230 | BUSH | 1 | 1 | 1 | 1 | | | | |
| 29 | 3 | X0535050620 | COVER | 1 | 1 | 1 | 1 | | | | |
| 30 | 3 | X0535130241 | PLATE | 1 | 1 | 1 | 1 | | | | |
| 31 | 3 | X0535130320 | PLATE | 1 | 1 | 1 | 1 | | | | |
| 32 | 3 | X0536600401 | PLUNGER | 1 | 1 | 1 | 1 | | | | |
| 33 | 3 | X9151005141 | BOLT | 3 | 3 | 3 | 3 | | | | |
| 34 | 3 | X9490170900 | WASHER | 1 | 1 | 1 | 1 | | | | |
| 35 | 3 | X9490170900 | WASHER | 1 | 1 | 1 | 1 | | | | |
| 36 | 3 | X9490441303 | BOLT | 1 | 1 | 1 | 1 | | | | |
| 37 | 3 | X9490441312 | BOLT | 1 | 1 | 1 | 1 | | | | |
| 38 | 3 | X9490502820 | NUT | 1 | 1 | 1 | 1 | | | | |
| 39 | 3 | X9490502820 | NUT | 1 | 1 | 1 | 1 | | | | |
| 40 | 3 | X9491402100 | O-RING | 1 | 1 | 1 | 1 | | | | |
| 41 | 3 | X9491402100 | O-RING | 1 | 1 | 1 | 1 | | | | |
| 42 | 2 | X9019008651 | NUT | 1 | 1 | 1 | 1 | | | | |
| 43 | 2 | X9025808001 | WASHER | 1 | 1 | 1 | 1 | | | | |
| 44 | 2 | X9490071810 | SCREW | 2 | 2 | 2 | 2 | | | | |
| 45 | 2 | X9490071970 | SCREW | 2 | 2 | 2 | 2 | | | | |
| 46 | 2 | X9490423330 | BOLT | 2 | 2 | 2 | 2 | | | | |
| 47 | 2 | X9490561370 | NUT | 1 | 1 | 1 | 1 | | | | |
| 48 | 2 | X9491200240 | BALL | 1 | 1 | 1 | 1 | | | | |
| 49 | 2 | X9491703380 | SPRING | 1 | 1 | 1 | 1 | | | | |

(A)=3TNE78A-SA
(B)=3TNE78A-G1A
(C)=3TNE78A-G2A

(D)=3TNE78AC-G1A
(E)=
(F)=

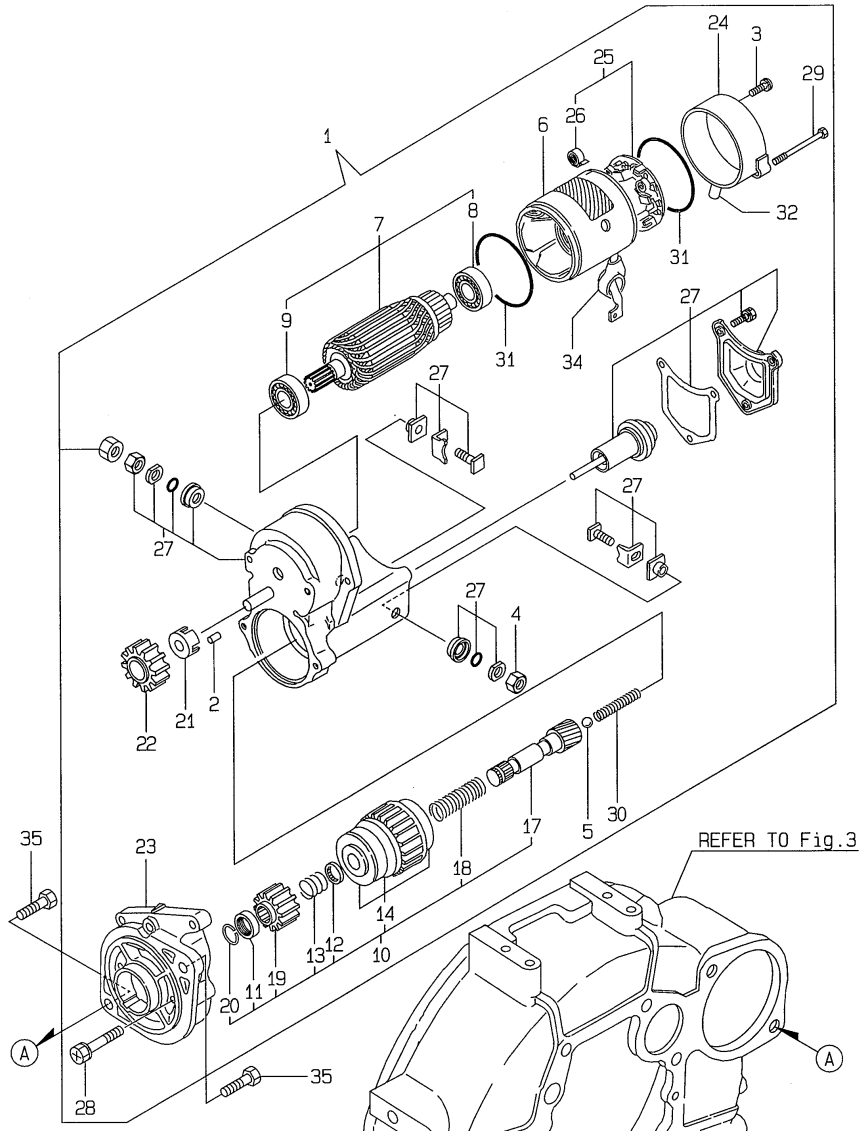

| No. | Lev. | Parts No. | Description | Q'ty | | | | | | I | R |
|------|------|--------------|----------------------|------------|------------|-----|-----|-----|-----|---|---|
| | | | | (A) | (B) | (C) | (D) | (E) | (F) | | |
| 1 | 1 | 129129-77010 | STARTER ASSY | 1 | 1 | 1 | 1 | | | | |
| 2 | 2 | X0283060061 | ROLLER | 5 | 5 | 5 | 5 | | | | |
| 3 | 2 | X0289030010 | SCREW | 2 | 2 | 2 | 2 | | | | |
| 3-1 | 2 | 129129-77460 | SCREW | 2 | 2 | 2 | 2 | | | | R |
| | | (A=E12915) | (B=E12951) | (C=E12840) | (D=E01796) | | | | | | |
| 4 | 2 | X9490561370 | NUT | 1 | 1 | 1 | 1 | | | | |
| 5 | 2 | X9491200240 | BALL | 1 | 1 | 1 | 1 | | | | |
| 6 | 2 | 129129-77210 | YOKE ASSY | 1 | 1 | 1 | 1 | | | | |
| 7 | 2 | 129129-77220 | ARMATURE ASSY | 1 | 1 | 1 | 1 | | | | |
| 8 | 3 | 129129-77230 | BEARING | 1 | 1 | 1 | 1 | | | | |
| 9 | 3 | 129129-77240 | BEARING | 1 | 1 | 1 | 1 | | | | |
| 10 | 2 | 129129-77250 | STARTER | 1 | 1 | 1 | 1 | | | | |
| 11 | 3 | X0280210230 | NUT | 1 | 1 | 1 | 1 | | | | |
| 12 | 3 | X0283270140 | RETAINER | 1 | 1 | 1 | 1 | | | | |
| 13 | 3 | X9491703371 | SPRING, COIL | 1 | 1 | 1 | 1 | | | | |
| 14 | 3 | 129129-77390 | CLUTCH ASSY | 1 | 1 | 1 | 1 | | | | |
| 17 | 3 | 129129-77400 | SHAFT | 1 | 1 | 1 | 1 | | | | |
| 18 | 3 | 129129-77410 | SPRING, COIL | 1 | 1 | 1 | 1 | | | | |
| 19 | 3 | 129129-77420 | PINION, STARTER | 1 | 1 | 1 | 1 | | | | |
| 20 | 3 | 129129-77430 | RING | 1 | 1 | 1 | 1 | | | | |
| 21 | 2 | 129129-77260 | RETAINER | 1 | 1 | 1 | 1 | | | | |
| 22 | 2 | 129129-77270 | PINION | 1 | 1 | 1 | 1 | | | | |
| 23 | 2 | 129129-77280 | HOUSING | 1 | 1 | 1 | 1 | | | | |
| 24 | 2 | 129129-77290 | FRAME | 1 | 1 | 1 | 1 | | | | |
| 25 | 2 | 129129-77300 | HOLDER ASSY | 1 | 1 | 1 | 1 | | | | |
| 26 | 3 | X9491730461 | SPRING | 4 | 4 | 4 | 4 | | | | |
| 27 | 2 | 129129-77310 | SWITCH ASSY | 1 | 1 | 1 | 1 | | | | |
| 28 | 2 | 129129-77320 | BOLT | 2 | 2 | 2 | 2 | | | | |
| 29 | 2 | 129129-77330 | BOLT | 2 | 2 | 2 | 2 | | | | |
| 30 | 2 | 129129-77340 | SPRING | 1 | 1 | 1 | 1 | | | | |
| 31 | 2 | 129129-77350 | O-RING | 2 | 2 | 2 | 2 | | | | |
| 32 | 2 | 129129-77361 | BUSH | 1 | 1 | 1 | 1 | | | | |
| 32-1 | 2 | 129129-77362 | COVER | 1 | 1 | 1 | 1 | | | | R |
| | | (A=E12915) | (B=E12951) | (C=E12840) | (D=E01796) | | | | | | |
| 34 | 2 | 129129-77380 | CAP | 1 | 1 | 1 | 1 | | | | |
| 35 | 1 | 26116-120252 | BOLT, M12X 25 PLATED | 2 | 2 | 2 | 2 | | | | |

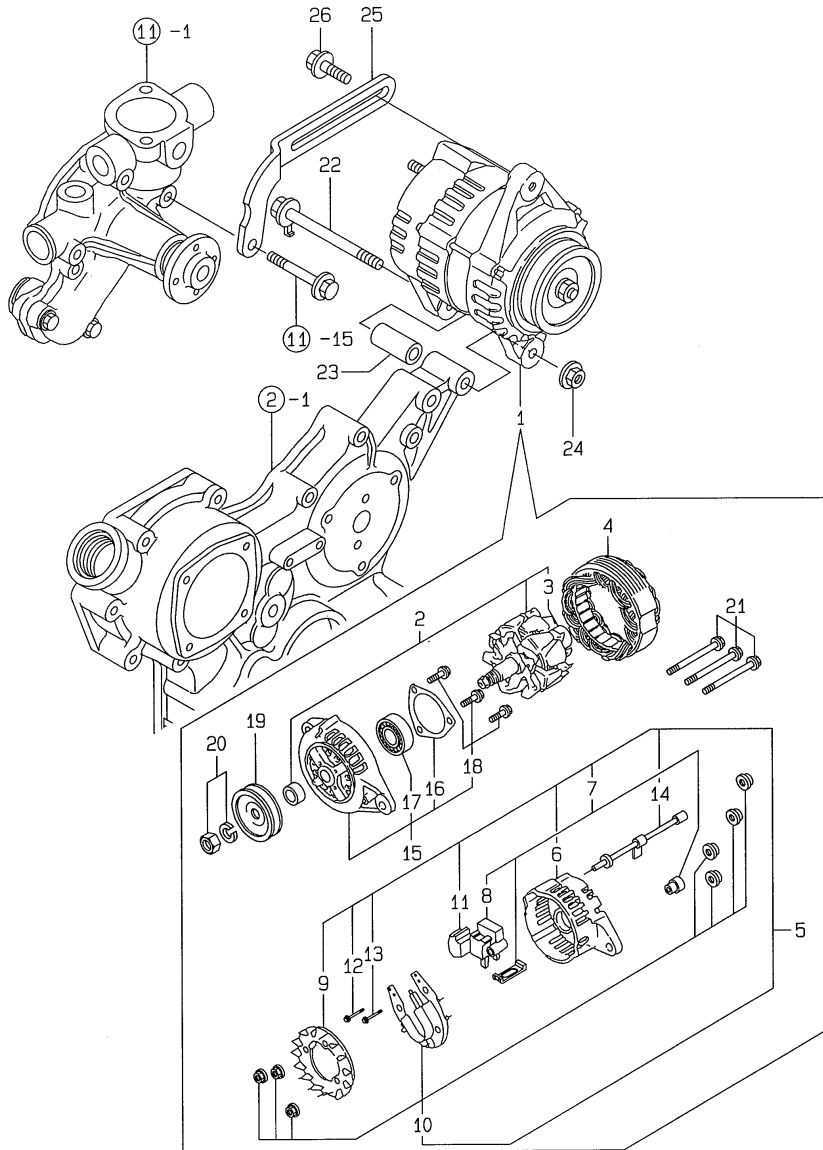

| No. | Lev. | Parts No. | Description | Qty | | | | | | I | R |
|------|------|--------------|----------------------|------------|------------|-----|-----|-----|-----|---|---|
| | | | | (A) | (B) | (C) | (D) | (E) | (F) | | |
| 1 | 1 | 119836-77200 | GENERATOR | 1 | 1 | 1 | 1 | | | | |
| 2 | 2 | 119836-77700 | ROTOR ASSY | 1 | 1 | 1 | 1 | | | | |
| 3 | 3 | 119836-77850 | BALL BEARING | 1 | 1 | 1 | 1 | | | | |
| 4 | 2 | 119836-77710 | STATOR ASSY | 1 | 1 | 1 | 1 | | | | |
| 5 | 2 | 119836-77721 | COVER ASSY, REAR | 1 | 1 | 1 | 1 | | | | |
| 6 | 3 | 119836-77730 | COVER, REAR | 1 | 1 | 1 | 1 | | | | |
| 7 | 3 | 119836-77741 | BRUSH ASSY,REGULATOR | 1 | 1 | 1 | 1 | | | | |
| 8 | 4 | 119836-77750 | BRUSH ASSY | 1 | 1 | 1 | 1 | | | | |
| 9 | 3 | 119836-77760 | GUIDE, FAN SIDE | 1 | 1 | 1 | 1 | | | | |
| 10 | 3 | 119836-77770 | DIODE ASSY | 1 | 1 | 1 | 1 | | | | |
| 11 | 3 | 119836-77780 | CONDENSER | 1 | 1 | 1 | 1 | | | | |
| 12 | 3 | 119836-77871 | BOLT (1) | 1 | 1 | 1 | 1 | | | | |
| 13 | 3 | 119836-77880 | BOLT (2) | 1 | 1 | 1 | 1 | | | | |
| 14 | 3 | 119836-77890 | WIRE ASSY, LEAD | 1 | 1 | 1 | 1 | | | | |
| 15 | 2 | 119836-77790 | COVER ASSY, FRONT | 1 | 1 | 1 | 1 | | | | |
| 16 | 3 | 119836-77800 | RETAINER, BEARING | 1 | 1 | 1 | 1 | | | | |
| 17 | 3 | 119836-77840 | BALL BEARING | 1 | 1 | 1 | 1 | | | | |
| 18 | 3 | 119836-77860 | SCREW KID | 1 | 1 | 1 | 1 | | | | |
| 19 | 2 | 119836-77810 | PULLEY | 1 | 1 | 1 | 1 | | | | |
| 20 | 2 | 119836-77820 | NUT ASSY, PULLEY | 1 | 1 | 1 | 1 | | | | |
| 21 | 2 | 119836-77830 | BOLT, THROUGH | 1 | 1 | 1 | 1 | | | | |
| 22 | 1 | 129136-77250 | BOLT M 8X105 | 1 | 1 | 1 | 1 | | | | |
| 22-1 | 1 | 129136-77251 | BOLT, M8X110 | 1 | 1 | 1 | 1 | | | | N |
| | | (A=E14548) | (B=E14653) | (C=E14549) | (D=E01873) | | | | | | |
| 23 | 1 | 119820-77340 | PIECE, DISTANCE | 1 | 1 | 1 | 1 | | | | |
| 24 | 1 | 26366-080002 | NUT, M8 | 1 | 1 | 1 | 1 | | | | |
| 25 | 1 | 129100-77330 | ADJUSTER | 1 | 1 | 1 | 1 | | | | |
| 26 | 1 | 26014-080252 | BOLT, M8X 25 | 1 | 1 | 1 | 1 | | | | |
| 26-1 | 1 | 119810-77340 | BOLT, ADJUSTER | 1 | 1 | 1 | 1 | | | | N |
| | | (A=E14548) | (B=E14653) | (C=E14549) | (D=E01873) | | | | | | |

(A)=3TNE78A-SA
(B)=3TNE78A-G1A
(C)=3TNE78A-G2A

(D)=3TNE78AC-G1A
(E)=
(F)=

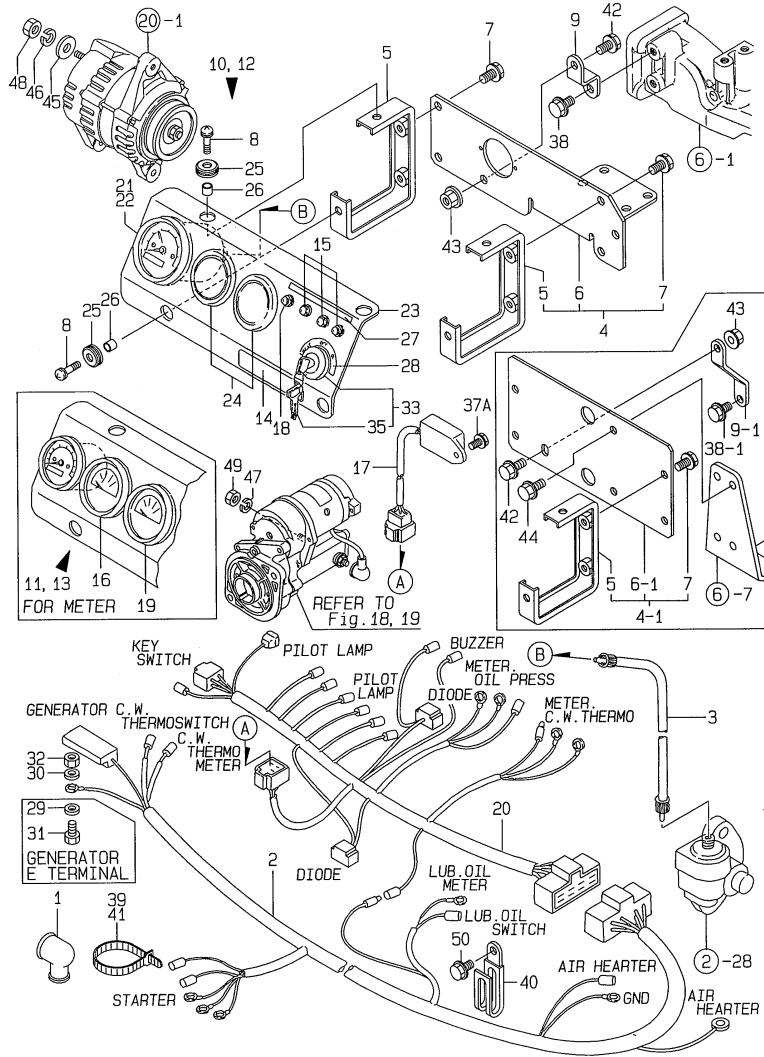

| No. | Lev. | Parts No. | Description | Q'ty | | | | | | I | R |
|------|------|---|----------------------|------|-----|-----|-----|-----|-----|---|---|
| | | | | (A) | (B) | (C) | (D) | (E) | (F) | | |
| 1 | 1 | 124550-77030 | COVER, TERMINAL | 1 | 1 | 1 | 1 | | | | |
| 2 | 1 | 119888-91022 | HARNES, WIRE | 1 | 1 | 1 | 1 | | | | |
| 3 | 1 | 124701-91140 | CABLE, L=985 | 1 | 1 | 1 | 1 | | | | |
| 4 | 1 | 119888-91150 | BRACKET ASSY | 1 | 1 | 1 | | | | | |
| 4-1 | 1 | 129608-91150 | BRACKET ASSY | 1 | 1 | 1 | 1 | | | | N |
| | | (A=E10184) (B=E10615) (C=E10201) | | | | | | | | | |
| 4-2 | 1 | 129608-91151 | BRACKET ASSY | 1 | 1 | 1 | 1 | | | | N |
| | | (A=E12915) (B=E12951) (C=E12582) (D=E01796) | | | | | | | | | |
| 5 | 2 | 119888-91120 | SUPPORT | 2 | 2 | 2 | 2 | | | | |
| 6 | 2 | 119888-91130 | BRACKET, PANEL | 1 | 1 | 1 | | | | | |
| 6-1 | 2 | 129608-91130 | BRACKET, PANEL | 1 | 1 | 1 | 1 | | | | N |
| | | (A=E10184) (B=E10615) (C=E10201) | | | | | | | | | |
| 6-2 | 2 | 129608-91131 | BRACKET, PANEL | 1 | 1 | 1 | 1 | | | | N |
| | | (A=E12915) (B=E12951) (C=E12582) (D=E01796) | | | | | | | | | |
| 7 | 2 | 26106-080122 | BOLT, M8X 12 PLATED | 4 | 4 | 4 | 4 | | | | |
| 8 | 1 | 26033-060202 | SCREW M 6X 20 | 4 | 4 | 4 | 4 | | | | |
| 9 | 1 | 119888-91141 | RETAINER, PANEL | 1 | 1 | 1 | | | | | |
| 9-1 | 1 | 129608-91140 | RETAINER, PANEL | 1 | 1 | 1 | 1 | | | | N |
| | | (A=E10184) (B=E10615) (C=E10201) | | | | | | | | | |
| 10 | 1 | 119888-91101 | PANEL ASSY | 1 | | 1 | | | | | |
| 11 | 1 | 119888-91201 | PANEL ASSY | 1 | | 1 | | | | | 1 |
| 12 | 1 | 119888-91301 | PANEL ASSY, INSTRUM | | 1 | | 1 | | | | |
| 13 | 1 | 119888-91311 | PANEL ASSY | | 1 | | 1 | | | | 1 |
| 14 | 2 | 104507-07190 | LABEL, YANMAR | 1 | 1 | 1 | 1 | | | | |
| 15 | 2 | 124732-77720 | LAMP, CHARGING | 3 | 3 | 3 | 3 | | | | |
| 16 | 2 | 171010-77850 | THERMOSTAT | 1 | 1 | 1 | 1 | | | | |
| 17 | 2 | 128300-77920 | TIMER | 1 | 1 | 1 | 1 | | | | |
| 18 | 2 | 124559-77971 | LAMP, PILOT | 1 | 1 | 1 | 1 | | | | |
| 19 | 2 | 171090-91010 | GAUGE | 1 | 1 | 1 | 1 | | | | |
| 20 | 2 | 119888-91031 | HARNES, WIRE | 1 | 1 | 1 | 1 | | | | |
| 21 | 2 | 171080-91100 | TACHOMETER | 1 | | 1 | | | | | |
| 22 | 2 | 171082-91100 | TACHOMETER | | 1 | | 1 | | | | |
| 23 | 2 | 119888-91110 | BODY, PANEL | 1 | 1 | 1 | 1 | | | | |
| 24 | 2 | 124770-91220 | COVER | 2 | 2 | 2 | 2 | | | | |
| 25 | 2 | 121400-91520 | ABSORBER | 4 | 4 | 4 | 4 | | | | |
| 26 | 2 | 121400-91530 | SPACER | 4 | 4 | 4 | 4 | | | | |
| 27 | 2 | 119888-91610 | LABEL, CW & OIL LAMP | 1 | 1 | 1 | 1 | | | | |
| 28 | 2 | 119888-91620 | LABEL, KEY SWITCH | 1 | 1 | 1 | 1 | | | | |
| 29 | 2 | 22117-050000 | WASHER, 5 | 1 | | 1 | | | | | |
| 30 | 2 | 22117-050000 | WASHER, 5 | 1 | | 1 | | | | | |
| 31 | 2 | 26116-050102 | BOLT, M5X 10 PLATED | 1 | | 1 | | | | | |
| 32 | 2 | 26716-050002 | NUT, M5 | 1 | | 1 | | | | | |
| 33 | 2 | 933110-00100 | SWITCH ASSY, STARTER | 1 | 1 | 1 | 1 | | | | |
| 35 | 3 | 933110-00301 | KEY ASSY | 1 | 1 | 1 | 1 | | | | |
| 37A | 2 | 26106-060102 | BOLT, M6X 10 PLATED | 1 | 1 | 1 | 1 | | | | W |
| | | (A=E10184) (B=E10615) (C=E10201) | | | | | | | | | |
| 38 | 1 | 26106-080122 | BOLT, M8X 12 PLATED | 1 | 1 | 1 | | | | | |
| 38-1 | 1 | 26106-080162 | BOLT, M8X 16 PLATED | 1 | 1 | 1 | 1 | | | | N |
| | | (A=E10184) (B=E10615) (C=E10201) | | | | | | | | | |
| 39 | 1 | 121750-59890 | BAND, 140 | 1 | 1 | 1 | 1 | | | | |
| 40 | 1 | 194180-51640 | CLAMP, HARNES | 1 | 1 | 1 | 1 | | | | |

Remarks

(1) WITH C.W.THERMOMETER(REF.NO.16, P/# 171010-77850) & PRESSURE GAUGE(REF.NO.19,P/# 171090-91010).

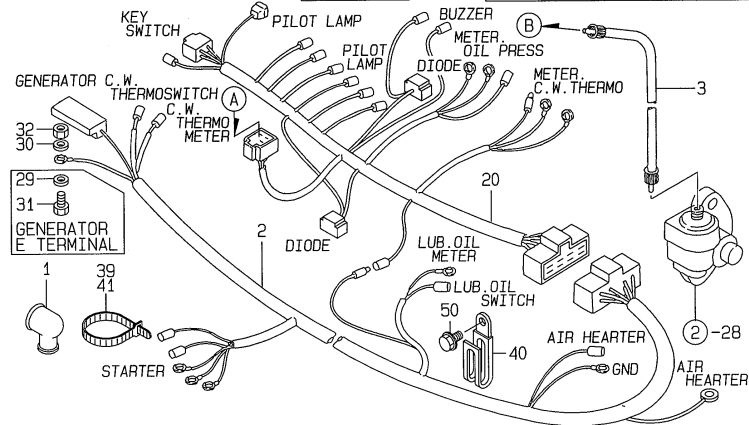
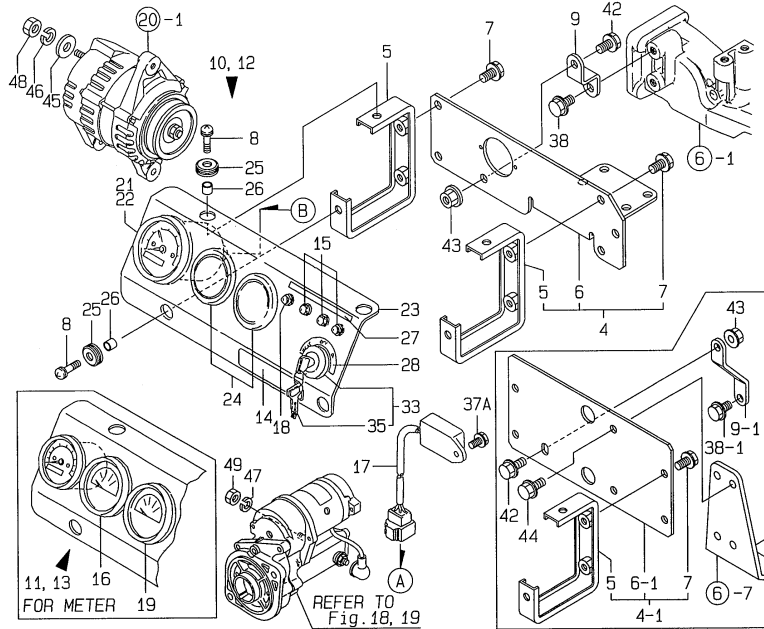

| No. | Lev. | Parts No. | Description | Q'ty | | | | | | I | R |
|------|------|--------------|----------------------|------------|------------|-----|-----|-----|-----|---|---|
| | | | | (A) | (B) | (C) | (D) | (E) | (F) | | |
| 41 | 1 | 121750-59890 | BAND, 140 | 1 | | | | | | | |
| 42 | 1 | 26106-080162 | BOLT, M8X 16 PLATED | 1 | 1 | 1 | 1 | | | | |
| 43 | 1 | 26366-080002 | NUT, M8 | 1 | 1 | 1 | 1 | | | | |
| 43-1 | 1 | 26306-080002 | NUT, M8 | 1 | 1 | 1 | 1 | | | | N |
| | | (A=E10184) | (B=E10615) | (C=E10201) | (D=E10201) | | | | | | |
| 44 | 1 | 26106-080162 | BOLT, M8X 16 PLATED | 2 | 2 | 2 | 2 | | | | W |
| | | (A=E10184) | (B=E10615) | (C=E10201) | (D=E10201) | | | | | | |
| 45 | 1 | 22117-050000 | WASHER, 5 | 1 | 1 | 1 | 1 | | | | W |
| | | (A=E10184) | (B=E10615) | (C=E10201) | (D=E10201) | | | | | | |
| 46 | 1 | 22217-050000 | WASHER, SPRING 5 | 1 | 1 | 1 | 1 | | | | W |
| | | (A=E10184) | (B=E10615) | (C=E10201) | (D=E10201) | | | | | | |
| 47 | 1 | 22217-080000 | WASHER, SPRING 8 | 1 | 1 | 1 | 1 | | | | W |
| | | (A=E10184) | (B=E10615) | (C=E10201) | (D=E10201) | | | | | | |
| 48 | 1 | 26716-050002 | NUT, M5 | 1 | 1 | 1 | 1 | | | | W |
| | | (A=E10184) | (B=E10615) | (C=E10201) | (D=E10201) | | | | | | |
| 49 | 1 | 26756-080002 | NUT, LOCK M8 | 1 | 1 | 1 | 1 | | | | W |
| | | (A=E10184) | (B=E10615) | (C=E10201) | (D=E10201) | | | | | | |
| 50 | 1 | 26106-100122 | BOLT, M10X 12 PLATED | 1 | | | | | | | W |
| | | (A=E10184) | | | | | | | | | |

Remarks
(1) WITH C.W.THERMOMETER(REF.NO.16,
P/# 171010-77850) & PRESSURE
GAUGE(REF.NO.19,P/# 171090-91010).

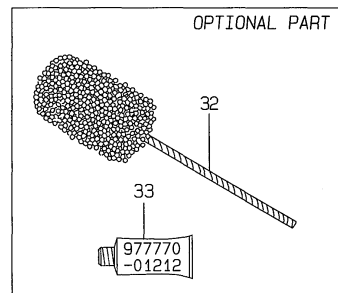
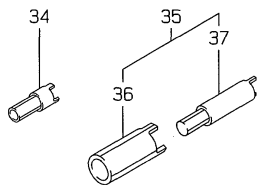
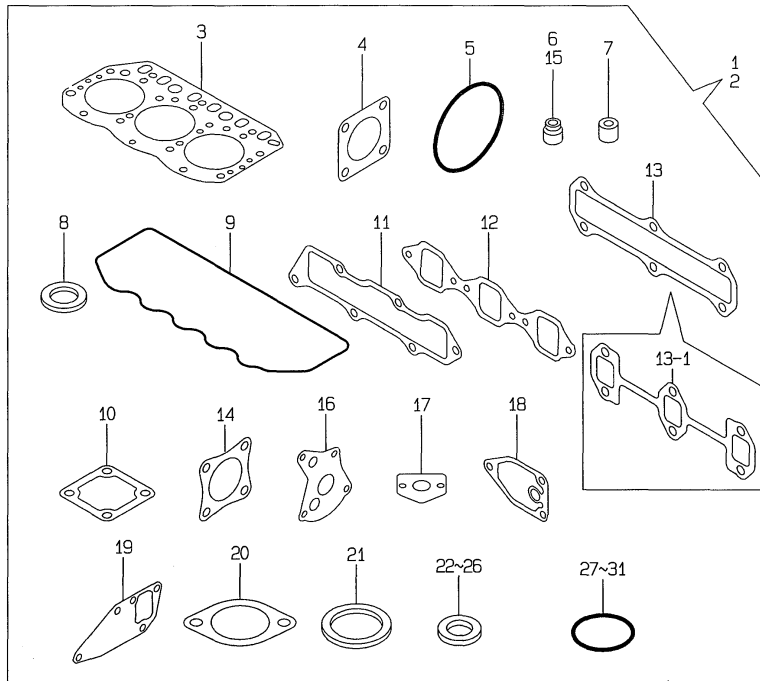

| No. | Lev. | Parts No. | Description | Q'ty | | | | | | I | R |
|------|------|---|--------------------|------|-----|-----|-----|-----|-----|---|---|
| | | | | (A) | (B) | (C) | (D) | (E) | (F) | | |
| 1 | 1 | 719822-92600 | GASKET SET | 1 | 1 | | 1 | | | | |
| 2 | 1 | 719822-92610 | GASKET SET | | | | | | | | 1 |
| 3 | 2 | 119818-01330 | GASKET, HEAD | 1 | 1 | 1 | 1 | | | | |
| 4 | 2 | 124240-01883 | GASKET | 1 | 1 | 1 | 1 | | | | |
| 5 | 2 | 121850-51960 | O-RING | 1 | 1 | 1 | 1 | | | | |
| 6 | 2 | 124160-11340 | SEAL, VALVE STEM | 3 | 3 | 3 | 3 | | | | |
| 7 | 2 | 119625-11871 | PROTECTOR, NOZZLE | 3 | 3 | 3 | 3 | | | | |
| 7-1 | 2 | 119625-11870 | PROTECTOR, NOZZLE | 3 | 3 | 3 | 3 | | | | N |
| | | (A=E10184) (B=E10615) (C=E10201) (D=E00973) | | | | | | | | | |
| 8 | 2 | 119625-11880 | SEAT, NOZZLE | 3 | 3 | 3 | 3 | | | | |
| 9 | 2 | 119865-11310 | GASKET, BONNET | 1 | 1 | 1 | 1 | | | | |
| 10 | 2 | 129150-77511 | GASKET | 1 | 1 | 1 | 1 | | | | |
| 11 | 2 | 119813-12110 | GASKET, MANIFOLD | 1 | 1 | | 1 | | | | |
| 12 | 2 | 119810-12111 | GASKET, MANIFOLD | | | | | 1 | | | |
| 13 | 2 | 119813-13110 | GASKET | 1 | 1 | 1 | 1 | | | | |
| 13-1 | 2 | 119810-13110 | GASKET | | | | | 1 | | | S |
| | | (C=FROM 1ST) | | | | | | | | | |
| 14 | 2 | 121000-13201 | GASKET, SILENCER | 1 | 1 | 1 | 1 | | | | |
| 15 | 2 | 124950-11340 | SEAL, VALVE STEM | 3 | 3 | 3 | 3 | | | | |
| 16 | 2 | 129150-32020 | GASKET, PUMP | 1 | 1 | 1 | 1 | | | | |
| 17 | 2 | 129150-35041 | GASKET | 1 | 1 | 1 | 1 | | | | |
| 18 | 2 | 129150-35111 | GASKET | 1 | 1 | 1 | 1 | | | | |
| 19 | 2 | 129150-42020 | GASKET, WATER PUMP | 1 | 1 | 1 | 1 | | | | |
| 20 | 2 | 129795-49551 | GASKET | 1 | 1 | 1 | 1 | | | | |
| 21 | 2 | 129150-49811 | GASKET, THERMOSTAT | 1 | 1 | 1 | 1 | | | | |
| 22 | 2 | 104200-59170 | GASKET, 12 | 2 | 2 | 2 | 2 | | | | |
| 22-1 | 2 | 22190-120002 | WASHER, SEAL 12 | 2 | 2 | 2 | 2 | | | | N |
| | | (A=E10184) (B=E10615) (C=E10201) (D=E00973) | | | | | | | | | |
| 23 | 2 | 22190-080002 | WASHER, SEAL 6 | 5 | 5 | 5 | 5 | | | | |
| 24 | 2 | 129150-49360 | GASKET | 1 | 1 | 1 | 1 | | | | |
| 25 | 2 | 23414-120000 | GASKET, 12X1.0 | 2 | 2 | 2 | 2 | | | | |
| 26 | 2 | 124465-44950 | GASKET, 16 | 2 | 2 | 2 | 2 | | | | |
| 27 | 2 | 24311-000120 | O-RING, 1AP12.0 | 3 | 3 | 3 | 3 | | | | |
| 28 | 2 | 24311-000160 | O-RING, 1AP16.0 | 2 | 2 | 2 | 2 | | | | |
| 29 | 2 | 24311-000320 | O-RING, 1AP32.0 | 2 | 2 | 2 | 2 | | | | |
| 30 | 2 | 24341-000240 | O-RING, 1AS24.0 | 1 | 1 | 1 | 1 | | | | |
| 31 | 2 | 24341-000500 | O-RING, 1AS50.0 | 1 | 1 | 1 | 1 | | | | |
| 32 | 1 | 129400-92420 | HONE | 1 | 1 | 1 | 1 | | | | 1 |
| 33 | 1 | 977770-01212 | GASKET, LIQUID | 1 | 1 | 1 | 1 | | | | 1 |
| 34 | 1 | 119621-99100 | TOOL, CARB IDLE | | | | | | | 1 | W |
| | | (D=E10184) | | | | | | | | | |
| 35 | 1 | 119621-99400 | BOX, TOOL | | | | | | | 1 | W |
| | | (D=E10184) | | | | | | | | | |
| 36 | 2 | 119621-99200 | TOOL, CARB A | | | | | | | 1 | W |
| | | (D=E10184) | | | | | | | | | |
| 37 | 2 | 119621-99300 | TOOL, CARB B | | | | | | | 1 | W |
| | | (D=E10184) | | | | | | | | | |

Remarks

(1) OPTIONAL PART.



Parts No. Index

| Parts No. | Fig. No. | Ref. No. |
|--------------|----------|----------|
| 101304-59020 | 16 | 13 |
| 102103-55520 | 16 | 8 |
| 103854-39140 | 16 | 12 |
| 104200-55330 | 16 | 3 |
| 104200-55750 | 16 | 5 |
| 104200-59170 | 16 | 15 |
| | 22 | 22 |
| 104200-66820 | 17 | 9 |
| 104200-66830 | 17 | 10 |
| 104200-66850 | 17 | 11 |
| 104200-66860 | 17 | 12 |
| 104211-11180 | 4 | 15 |
| | 5 | 24 |
| 104211-11370 | 4 | 19 |
| | 5 | 28 |
| 104507-07190 | 21 | 14 |
| 105025-59750 | 15 | 66 B |
| | 16 | 19 |
| 110250-55610 | 16 | 7 |
| 114250-53080 | 15 | 12 |
| 114250-53120 | 15 | 16 |
| 114250-53130 | 15 | 17 |
| 114250-53140 | 15 | 18 |
| 114250-53210 | 15 | 19 |
| 114250-53400 | 15 | 20 |
| 119131-18320 | 7 | 4 -1 |
| 119259-44570 | 12 | 5 |
| 119305-59120 | 15 | 27 |
| 119358-13640 | 7 | 13 |
| 119600-34800 | 10 | 16 |
| 119620-01750 | 3 | 7 |
| 119620-02020 | 1 | 13 |
| 119620-13501 | 7 | 8 |
| 119620-13510 | 7 | 9 |
| 119620-13520 | 7 | 10 |
| 119620-13560 | 7 | 11 |
| 119621-44500 | 12 | 4 |
| 119621-44560 | 12 | 6 |
| 119621-66610 | 14 | 94 |
| 119621-66710 | 14 | 96 |
| 119621-99100 | 22 | 34 |
| 119621-99200 | 22 | 36 |
| 119621-99300 | 22 | 37 |
| 119621-99400 | 22 | 35 |
| 119625-11870 | 4 | 20 -1 |
| | 5 | 42 -1 |
| | 22 | 7 -1 |
| 119625-11871 | 4 | 20 |
| | 5 | 42 |
| | 22 | 7 |

| Parts No. | Fig. No. | Ref. No. |
|--------------|----------|----------|
| 119625-11880 | 4 | 21 |
| | 5 | 43 |
| | 22 | 8 |
| 119625-11900 | 4 | 22 |
| | 5 | 44 |
| 119640-01640 | 3 | 14 |
| | | 20 |
| 119653-77950 | 14 | 90 |
| 119660-61901 | 14 | 65 |
| 119685-61940 | 14 | 82 A |
| 119685-61950 | 14 | 82 B |
| 119808-12520 | 6 | 16 |
| | | 23 |
| 119808-12530 | 6 | 17 |
| | | 24 |
| 119808-12540 | 6 | 18 |
| | | 26 |
| 119810-01200 | 1 | 22 |
| 119810-01730 | 3 | 17 |
| 119810-01770 | 3 | 19 |
| 119810-01780 | 3 | 28 |
| 119810-01790 | 3 | 13 |
| 119810-02800 | 1 | 14 |
| 119810-02870 | 1 | 24 |
| 119810-02930 | 1 | 17 |
| 119810-02940 | 1 | 27 |
| 119810-11100 | 4 | 12 |
| | 5 | 21 |
| 119810-11110 | 4 | 13 |
| 119810-11120 | 4 | 14 |
| | 5 | 22 |
| 119810-11130 | 5 | 23 |
| 119810-11240 | 4 | 26 |
| | 5 | 31 |
| 119810-12111 | 6 | 19 |
| | 22 | 12 |
| 119810-13110 | 7 | 2 -1 |
| | 22 | 13 -1 |
| 119810-14400 | 8 | 2 |
| 119810-14580 | 8 | 3 |
| 119810-23200 | 9 | 42 |
| 119810-23600 | 9 | 43 |
| 119810-23610 | 9 | 45 |
| 119810-23910 | 9 | 41 |
| 119810-35300 | 10 | 20 |
| 119810-35401 | 10 | 19 |
| 119810-39200 | 10 | 34 |
| 119810-42001 | 11 | 1 |
| 119810-51040 | 13 | 9 |
| 119810-55340 | 16 | 2 |

| Parts No. | Fig. No. | Ref. No. |
|--------------|----------|----------|
| 119810-55650 | 16 | 9 |
| 119810-77340 | 20 | 26 -1 |
| 119811-59810 | 15 | 34 |
| 119811-59820 | 15 | 40 |
| 119811-59830 | 15 | 46 |
| 119812-11700 | 4 | 4 |
| 119813-12100 | 6 | 1 |
| 119813-12110 | 6 | 3 |
| | 22 | 11 |
| 119813-13100 | 7 | 1 |
| 119813-13110 | 7 | 2 |
| | 22 | 13 |
| 119813-21000 | 9 | 1 |
| 119813-22300 | 9 | 35 |
| 119813-59811 | 15 | 33 |
| 119813-59812 | 15 | 33 -1 |
| 119813-59821 | 15 | 39 |
| 119813-59831 | 15 | 45 |
| 119818-01330 | 1 | 23 |
| | 22 | 3 |
| 119818-22080 | 9 | 26 |
| 119818-22090 | 9 | 27 |
| 119818-22500 | 9 | 29 |
| 119818-22510 | 9 | 30 |
| 119818-22900 | 9 | 47 |
| 119818-22950 | 9 | 49 |
| 119818-53000 | 15 | 5 |
| 119820-77340 | 20 | 23 |
| 119822-12500 | 6 | 21 |
| 119822-12510 | 6 | 22 |
| 119822-44940 | 12 | 8 |
| 119822-44950 | 12 | 44 |
| 119822-44970 | 12 | 43 |
| 119833-55620 | 16 | 1 |
| 119836-77200 | 20 | 1 |
| 119836-77700 | 20 | 2 |
| 119836-77710 | 20 | 4 |
| 119836-77721 | 20 | 5 |
| 119836-77730 | 20 | 6 |
| 119836-77741 | 20 | 7 |
| 119836-77750 | 20 | 8 |
| 119836-77760 | 20 | 9 |
| 119836-77770 | 20 | 10 |
| 119836-77780 | 20 | 11 |
| 119836-77790 | 20 | 15 |
| 119836-77800 | 20 | 16 |
| 119836-77810 | 20 | 19 |
| 119836-77820 | 20 | 20 |
| 119836-77830 | 20 | 21 |
| 119836-77840 | 20 | 17 |

| Parts No. | Fig. No. | Ref. No. |
|--------------|----------|----------|
| 119836-77850 | 20 | 3 |
| 119836-77860 | 20 | 18 |
| 119836-77871 | 20 | 12 |
| 119836-77880 | 20 | 13 |
| 119836-77890 | 20 | 14 |
| 119840-59560 | 15 | 53 |
| 119840-59570 | 15 | 54 |
| 119843-61540 | 14 | 54 |
| 119865-11200 | 4 | 24 |
| | 5 | 30 |
| 119865-11210 | 4 | 24 -1 |
| | | 25 |
| 119865-11310 | 4 | 49 |
| | 5 | 55 |
| | 22 | 9 |
| 119865-21600 | 9 | 17 |
| | | 25 |
| 119888-01600 | 3 | 2 |
| 119888-08100 | 12 | 1 |
| 119888-08110 | 12 | 2 |
| 119888-13101 | 7 | 1 -1 |
| 119888-21450 | 9 | 53 |
| 119888-21590 | 9 | 14 |
| 119888-44950 | 12 | 9 |
| 119888-44960 | 12 | 10 |
| 119888-44970 | 12 | 11 |
| 119888-44980 | 12 | 12 |
| 119888-66110 | 17 | 5 |
| 119888-66120 | 17 | 1 |
| 119888-66130 | 17 | 6 |
| 119888-66150 | 17 | 2 |
| 119888-66160 | 17 | 3 A |
| 119888-91022 | 21 | 2 |
| 119888-91031 | 21 | 20 |
| 119888-91101 | 21 | 10 |
| 119888-91110 | 21 | 23 |
| 119888-91120 | 21 | 5 |
| 119888-91130 | 21 | 6 |
| 119888-91141 | 21 | 9 |
| 119888-91150 | 21 | 4 |
| 119888-91201 | 21 | 11 |
| 119888-91301 | 21 | 12 |
| 119888-91311 | 21 | 13 |
| 119888-91610 | 21 | 27 |
| 119888-91620 | 21 | 28 |
| 119988-61070 | 14 | 9 A |
| 119988-61400 | 14 | 22 A |
| 119988-61460 | 14 | 29 A |
| 121000-13201 | 7 | 7 |
| | | 24 |



Parts No. Index

| Parts No. | Fig. No. | Ref. No. |
|--------------|----------|----------|
| 121000-13201 | 22 | 14 |
| 121023-01550 | 2 | 25 |
| 121111-21501 | 9 | 13 |
| 121120-77930 | 18 | 12 |
| 121250-44590 | 12 | 5 C |
| 121250-44901 | 11 | 33 |
| 121250-55620 | 16 | 10 |
| 121250-59550 | 15 | 52 |
| 121254-55510 | 16 | 6 |
| 121256-44600 | 12 | 29 |
| 121400-44640 | 12 | 45 |
| 121400-44650 | 12 | 7 |
| 121400-91520 | 21 | 25 |
| 121400-91530 | 21 | 26 |
| 121450-01560 | 2 | 6 |
| 121450-42450 | 11 | 29 |
| 121476-01620 | 3 | 6 |
| 121520-34810 | 10 | 17 |
| 121520-49160 | 12 | 39 |
| 121521-12400 | 6 | 6 |
| 121550-49111 | 11 | 28 |
| 121737-49160 | 12 | 38 |
| 121750-59890 | 12 | 42 |
| | 21 | 39 |
| | | 41 |
| 121850-11860 | 5 | 16 |
| 121850-21680 | 9 | 12 |
| 121850-51960 | 2 | 13 |
| | 22 | 5 |
| 121855-13821 | 7 | 14 |
| 121855-13830 | 7 | 15 |
| 122117-51560 | 13 | 57 |
| 122710-51090 | 13 | 13 |
| 123500-13840 | 7 | 16 |
| 124060-11800 | 4 | 8 |
| | 5 | 14 |
| 124066-59100 | 15 | 51 |
| 124160-01751 | 2 | 7 |
| | 4 | 59 |
| | 5 | 49 |
| 124160-01910 | 1 | 5 |
| | | 21 -1 |
| 124160-11340 | 4 | 17 |
| | 5 | 26 |
| | 22 | 6 |
| 124160-11360 | 4 | 53 |
| | 5 | 59 |
| 124160-39140 | 10 | 33 |
| 124160-39450 | 10 | 38 |
| 124240-01871 | 2 | 8 |

| Parts No. | Fig. No. | Ref. No. |
|--------------|----------|----------|
| 124240-01883 | 2 | 9 |
| | 22 | 4 |
| 124250-49351 | 11 | 31 |
| 124450-44510 | 12 | 23 |
| 124450-44530 | 12 | 25 |
| 124450-44550 | 12 | 28 |
| 124450-44560 | 12 | 26 |
| 124465-44950 | 11 | 30 |
| | | 34 |
| | 22 | 26 |
| 124520-77011 | 18 | 2 |
| 124550-21600 | 9 | 21 |
| 124550-51350 | 13 | 39 |
| 124550-51370 | 13 | 40 |
| 124550-59820 | 10 | 39 |
| 124550-59830 | 10 | 38 A |
| 124550-66370 | 14 | 67 |
| 124550-77030 | 21 | 1 |
| 124559-77971 | 21 | 18 |
| 124574-44761 | 11 | 21 |
| 124664-13580 | 7 | 12 |
| 124700-44740 | 11 | 20 |
| 124701-11911 | 7 | 7 -1 |
| 124701-91140 | 21 | 3 |
| 124732-77720 | 21 | 15 |
| 124736-07900 | 4 | 2 |
| | 5 | 5 |
| 124766-59050 | 12 | 38 A |
| | | 39 A |
| | | 40 |
| | 15 | 65 |
| | | 66 A |
| | 16 | 14 |
| | | 15 B |
| | | 18 |
| 124770-91220 | 21 | 24 |
| 124950-11340 | 4 | 18 |
| | 5 | 27 |
| | 22 | 15 |
| 124950-51190 | 13 | 22 |
| 126650-12680 | 6 | 27 |
| 126650-66020 | 17 | 4 |
| 128170-51300 | 13 | 33 |
| 128300-77920 | 21 | 17 |
| 129001-01250 | 1 | 8 -1 |
| 129001-32001 | 10 | 1 |
| 129001-35300 | 10 | 29 |
| 129001-91840 | 2 | 21 -1 |
| 129051-12530 | 6 | 25 |
| 129052-61050 | 14 | 7 |

| Parts No. | Fig. No. | Ref. No. |
|--------------|----------|----------|
| 129052-61060 | 14 | 8 |
| 129052-61070 | 14 | 9 |
| 129052-61390 | 14 | 36 |
| 129052-61500 | 14 | 37 |
| 129052-61540 | 14 | 53 |
| 129100-01580 | 3 | 1 |
| | | 25 |
| | 9 | 2 |
| 129100-25061 | 8 | 9 |
| 129100-25900 | 8 | 19 |
| 129100-51300 | 13 | 32 |
| 129100-52100 | 13 | 103 |
| 129100-59951 | 15 | 56 |
| 129100-61400 | 14 | 22 |
| 129100-61440 | 14 | 84 |
| 129100-61650 | 14 | 85 |
| 129100-77330 | 20 | 25 |
| 129102-53000 | 15 | 6 |
| 129108-51100 | 13 | 14 |
| 129116-61051 | 14 | 7 A |
| 129120-77501 | 6 | 11 |
| 129129-01600 | 3 | 3 |
| 129129-77010 | 19 | 1 |
| 129129-77210 | 19 | 6 |
| 129129-77220 | 19 | 7 |
| 129129-77230 | 19 | 8 |
| 129129-77240 | 19 | 9 |
| 129129-77250 | 19 | 10 |
| 129129-77260 | 19 | 21 |
| 129129-77270 | 19 | 22 |
| 129129-77280 | 19 | 23 |
| 129129-77290 | 19 | 24 |
| 129129-77300 | 19 | 25 |
| 129129-77310 | 19 | 27 |
| 129129-77320 | 19 | 28 |
| 129129-77330 | 19 | 29 |
| 129129-77340 | 19 | 30 |
| 129129-77350 | 19 | 31 |
| 129129-77361 | 19 | 32 |
| 129129-77362 | 19 | 32 -1 |
| 129129-77380 | 19 | 34 |
| 129129-77390 | 19 | 14 |
| 129129-77400 | 19 | 17 |
| 129129-77410 | 19 | 18 |
| 129129-77420 | 19 | 19 |
| 129129-77430 | 19 | 20 |
| 129129-77460 | 19 | 3 -1 |
| 129132-44530 | 12 | 5 B |
| 129136-77250 | 20 | 22 |
| 129136-77251 | 20 | 22 -1 |

| Parts No. | Fig. No. | Ref. No. |
|--------------|----------|----------|
| 129150-02450 | 8 | 4 |
| 129150-03020 | 4 | 44 |
| | 5 | 50 |
| 129150-03070 | 4 | 45 |
| | 5 | 51 |
| 129150-03080 | 4 | 46 |
| | 5 | 52 |
| 129150-03100 | 2 | 11 |
| 129150-11230 | 4 | 34 |
| | 5 | 38 |
| 129150-11280 | 4 | 31 |
| | 5 | 36 |
| 129150-11750 | 4 | 37 |
| | 5 | 40 |
| 129150-14101 | 8 | 7 |
| 129150-14200 | 8 | 1 |
| 129150-21200 | 9 | 5 |
| 129150-25101 | 8 | 10 |
| 129150-25900 | 8 | 15 |
| 129150-25920 | 8 | 13 |
| 129150-32020 | 10 | 14 |
| | 22 | 16 |
| 129150-35041 | 10 | 18 |
| | 22 | 17 |
| 129150-35101 | 10 | 26 |
| 129150-35111 | 10 | 27 |
| | 22 | 18 |
| 129150-35151 | 10 | 28 |
| 129150-35350 | 10 | 30 |
| 129150-42020 | 11 | 14 |
| | 22 | 19 |
| 129150-42320 | 11 | 11 |
| 129150-49080 | 12 | 34 |
| 129150-49100 | 12 | 33 |
| 129150-49360 | 11 | 32 |
| | 22 | 24 |
| 129150-49811 | 11 | 26 |
| | 22 | 21 |
| 129150-59120 | 15 | 67 |
| 129150-59131 | 15 | 30 |
| | | 70 |
| 129150-59580 | 15 | 55 |
| 129150-77511 | 6 | 12 |
| | 22 | 10 |
| 129150-91400 | 2 | 28 |
| 129155-11260 | 4 | 29 |
| | 5 | 34 |
| 129155-11270 | 4 | 30 |
| | 5 | 35 |
| 129155-42350 | 11 | 19 |



Parts No. Index

| Parts No. | Fig. No. | Ref. No. |
|--------------|----------|----------|
| 129155-49800 | 11 | 25 |
| 129155-51020 | 13 | 8 |
| 129155-51050 | 13 | 11 |
| 129155-51060 | 13 | 12 |
| 129155-51140 | 13 | 19 |
| 129155-51180 | 13 | 21 |
| 129155-51200 | 13 | 23 |
| 129155-51270 | 13 | 30 |
| 129155-51280 | 13 | 31 |
| | 14 | 4 |
| 129155-51320 | 13 | 37 |
| 129155-51340 | 13 | 38 |
| 129155-51370 | 13 | 41 |
| 129155-51380 | 13 | 42 |
| 129155-51390 | 13 | 43 |
| 129155-51400 | 13 | 44 |
| 129155-51410 | 13 | 45 |
| 129155-51420 | 13 | 46 |
| 129155-51450 | 13 | 47 |
| 129155-51500 | 13 | 52 |
| 129155-51521 | 13 | 53 |
| 129155-51530 | 13 | 54 |
| 129155-51540 | 13 | 55 |
| 129155-51550 | 13 | 56 |
| 129155-51570 | 13 | 59 |
| 129155-51580 | 13 | 60 |
| 129155-51591 | 13 | 61 |
| 129155-51600 | 13 | 62 |
| 129155-51700 | 13 | 81 |
| 129155-51710 | 13 | 82 |
| 129155-51750 | 13 | 83 |
| 129155-51760 | 13 | 84 |
| 129155-51790 | 13 | 85 |
| 129155-51930 | 13 | 87 |
| 129155-51940 | 13 | 88 |
| 129155-52050 | 13 | 102 |
| 129155-61120 | 14 | 10 |
| 129155-61130 | 14 | 11 |
| 129155-61140 | 14 | 12 |
| 129155-61201 | 14 | 13 |
| 129155-61341 | 14 | 19 |
| 129155-61350 | 14 | 20 |
| 129155-61360 | 14 | 21 |
| 129155-61430 | 14 | 25 |
| 129155-61450 | 14 | 29 |
| 129155-61460 | 14 | 30 |
| 129155-61470 | 14 | 92 |
| 129155-61480 | 14 | 31 |
| 129155-61830 | 14 | 64 |
| 129155-61950 | 14 | 66 |

| Parts No. | Fig. No. | Ref. No. |
|--------------|----------|----------|
| 129156-51910 | 13 | 86 |
| 129210-49120 | 12 | 38 B |
| 129210-49280 | 12 | 37 A |
| 129210-59040 | 16 | 15 A |
| 129210-59130 | 15 | 66 -1 |
| | 16 | 17 -1 |
| 129255-59580 | 15 | 66 |
| | 16 | 17 |
| 129350-49530 | 11 | 23 |
| 129400-01520 | 2 | 5 |
| 129400-92420 | 22 | 32 |
| 129403-42380 | 11 | 18 |
| 129411-51200 | 13 | 15 |
| 129412-61500 | 14 | 38 |
| 129470-39610 | 10 | 43 |
| 129477-61710 | 14 | 89 A |
| 129477-61720 | 14 | 88 |
| 129486-01670 | 3 | 29 -1 |
| 129500-53050 | 15 | 4 |
| 129500-61650 | 14 | 86 |
| 129500-61700 | 14 | 89 |
| 129550-21650 | 9 | 10 |
| 129555-59510 | 16 | 16 |
| 129608-12500 | 6 | 14 |
| 129608-12501 | 6 | 14 -1 |
| 129608-12510 | 6 | 15 |
| 129608-12511 | 6 | 15 -1 |
| 129608-12560 | 6 | 7 -1 |
| 129608-91130 | 21 | 6 -1 |
| 129608-91131 | 21 | 6 -2 |
| 129608-91140 | 21 | 9 -1 |
| 129608-91150 | 21 | 4 -1 |
| 129608-91151 | 21 | 4 -2 |
| 129612-01600 | 3 | 4 -1 |
| 129619-12210 | 6 | 5 |
| 129619-12560 | 6 | 7 |
| 129792-22400 | 9 | 36 |
| 129795-01800 | 2 | 4 |
| 129795-01950 | 2 | 10 |
| 129795-02411 | 1 | 20 |
| 129795-21661 | 9 | 11 |
| 129795-49551 | 11 | 24 |
| | 22 | 20 |
| 144626-91560 | 10 | 45 |
| 158552-61900 | 14 | 75 -1 |
| 170064-67210 | 17 | 22 |
| 171010-77850 | 21 | 16 |
| 171048-67010 | 17 | 7 |
| 171048-67130 | 17 | 16 |
| 171048-67140 | 17 | 17 |

| Parts No. | Fig. No. | Ref. No. |
|--------------|----------|----------|
| 171051-01921 | 1 | 6 |
| 171080-91100 | 21 | 21 |
| 171082-91100 | 21 | 22 |
| 171085-67100 | 17 | 13 |
| 171085-67110 | 17 | 14 |
| 171085-67120 | 17 | 15 |
| 171090-91010 | 21 | 19 |
| 171102-66080 | 17 | 8 |
| 171301-01600 | 3 | 4 |
| 171301-12701 | 6 | 20 |
| 171301-21580 | 9 | 22 |
| 171301-21590 | 9 | 18 |
| 171301-21650 | 9 | 9 |
| 171301-49010 | 12 | 30 |
| 171301-49020 | 12 | 31 |
| 171350-03090 | 4 | 1 |
| | 5 | 1 |
| 171353-61700 | 14 | 87 |
| 171375-39600 | 10 | 42 |
| 171375-39601 | 10 | 42 -1 |
| 171420-01600 | 3 | 5 |
| 171420-34820 | 10 | 16 -1 |
| 171488-61200 | 14 | 14 |
| 171488-61440 | 14 | 84 -1 |
| 174307-51170 | 13 | 20 |
| 174307-51560 | 13 | 58 |
| 174307-51700 | 14 | 39 |
| 194180-51640 | 21 | 40 |
| 194990-22050 | 7 | 5 |
| | | 23 |
| 22117-040000 | 14 | 68 |
| 22117-050000 | 21 | 29 |
| | | 30 |
| | | 45 |
| 22117-060000 | 17 | 27 A |
| 22117-100000 | 17 | 23 |
| 22137-080000 | 12 | 13 |
| | | 13 -1 |
| 22137-100000 | 17 | 23 -1 |
| 22190-060002 | 14 | 69 |
| 22190-060003 | 14 | 69 -1 |
| 22190-080002 | 2 | 12 |
| | | 23 |
| | 10 | 39 A |
| | | 41 |
| | | 41 -1 |
| | 22 | 23 |
| 22190-100002 | 14 | 70 |
| 22190-120002 | 14 | 71 |
| | 16 | 15 -1 |

| Parts No. | Fig. No. | Ref. No. |
|--------------|----------|----------|
| 22190-120002 | 22 | 22 -1 |
| 22190-160002 | 13 | 97 |
| 22190-220002 | 3 | 16 |
| | | 22 |
| 22217-050000 | 13 | 104 |
| | 21 | 46 |
| 22217-060000 | 13 | 89 |
| 22217-080000 | 21 | 47 |
| 22217-100000 | 12 | 14 |
| | 17 | 24 |
| 22217-120000 | 8 | 16 |
| 22272-000050 | 17 | 25 |
| 22287-120000 | 14 | 72 |
| 22351-020006 | 17 | 18 |
| 22351-040010 | 9 | 8 |
| 22351-050010 | 13 | 90 |
| 22351-060012 | 4 | 23 |
| | 5 | 29 |
| 22372-040000 | 14 | 73 |
| 22411-200150 | 17 | 19 |
| 22512-070140 | 8 | 8 |
| | 9 | 6 |
| 23000-060000 | 6 | 8 |
| 23010-038000 | 12 | 32 |
| 23061-070230 | 12 | 27 |
| 23161-020100 | 10 | 44 |
| 23414-100000 | 10 | 40 |
| 23414-120000 | 15 | 64 |
| | 22 | 25 |
| 23871-010000 | 1 | 7 |
| 23871-030000 | 5 | 17 |
| | 11 | 12 |
| 23876-010000 | 1 | 7 -1 |
| 23876-030000 | 5 | 17 -1 |
| | 11 | 12 -1 |
| 23887-100002 | 14 | 74 |
| 23887-120002 | 1 | 21 |
| 24101-063034 | 13 | 91 |
| 24104-062054 | 9 | 54 |
| 24311-000120 | 4 | 54 |
| | 5 | 60 |
| | 22 | 27 |
| 24311-000160 | 2 | 14 |
| | 10 | 31 |
| | 22 | 28 |
| 24311-000320 | 2 | 15 |
| | 4 | 60 |
| | 5 | 56 |
| | 22 | 29 |
| 24311-240100 | 16 | 4 |



Parts No. Index

| Parts No. | Fig. No. | Ref. No. |
|--------------|----------|----------|
| 24341-000160 | 13 | 92 |
| 24341-000240 | 2 | 26 |
| | | 30 |
| | 22 | 30 |
| 24341-000280 | 14 | 75 |
| 24341-000500 | 4 | 51 |
| | 5 | 57 |
| | 22 | 31 |
| 25132-003900 | 11 | 17 |
| 26013-080222 | 6 | 9 -1 |
| | | 10 -1 |
| 26014-080162 | 12 | 5 D |
| 26014-080252 | 20 | 26 |
| 26014-080702 | 16 | 11 |
| 26022-050102 | 13 | 93 |
| 26022-060162 | 13 | 94 |
| 26033-060202 | 21 | 8 |
| 26106-060102 | 14 | 76 |
| | | 77 |
| | | 78 |
| | 17 | 26 |
| | 21 | 37 A |
| 26106-060142 | 14 | 79 |
| 26106-060162 | 2 | 27 |
| | | 31 |
| 26106-060202 | 11 | 22 |
| | 14 | 80 |
| 26106-060402 | 7 | 22 |
| 26106-080122 | 2 | 16 |
| | 12 | 15 |
| | 21 | 7 |
| | | 38 |
| 26106-080142 | 4 | 3 |
| | 5 | 6 |
| | 8 | 18 -1 |
| 26106-080162 | 2 | 17 |
| | | 24 |
| | 3 | 23 |
| | 4 | 52 |
| | 5 | 58 |
| | 8 | 18 |
| | 12 | 16 |
| | | 41 |
| | 17 | 28 |
| | 21 | 38 -1 |
| | | 42 |
| | | 44 |
| 26106-080182 | 6 | 9 |
| | | 10 |
| 26106-080202 | 2 | 18 |

| Parts No. | Fig. No. | Ref. No. |
|--------------|----------|----------|
| 26106-080202 | 10 | 32 |
| | 11 | 27 |
| | 12 | 17 |
| 26106-080222 | 9 | 55 |
| | 11 | 27 -1 |
| 26106-080252 | 4 | 39 |
| | 5 | 45 |
| | 6 | 4 |
| | 12 | 18 |
| 26106-080302 | 3 | 29 |
| 26106-080352 | 3 | 30 |
| | 6 | 13 |
| | 10 | 25 |
| | 11 | 15 |
| 26106-080452 | 2 | 19 |
| | 3 | 24 |
| | 8 | 14 |
| 26106-080502 | 4 | 40 |
| | 5 | 46 |
| 26106-080552 | 2 | 20 |
| | 7 | 17 |
| | 11 | 16 |
| 26106-080602 | 7 | 3 |
| 26106-080852 | 2 | 21 |
| 26106-100122 | 21 | 50 |
| 26106-100202 | 12 | 3 |
| 26116-050102 | 21 | 31 |
| 26116-050302 | 13 | 95 |
| 26116-060082 | 17 | 20 |
| 26116-120252 | 18 | 1 |
| | 19 | 35 |
| 26206-100202 | 3 | 8 |
| 26206-100252 | 3 | 9 |
| | | 12 |
| 26206-100302 | 3 | 10 |
| 26206-120302 | 12 | 19 |
| 26216-060302 | 4 | 10 |
| | 5 | 18 |
| 26216-080222 | 7 | 4 |
| 26216-080602 | 7 | 6 |
| 26226-080182 | 4 | 38 |
| | 5 | 41 |
| 26306-080002 | 2 | 22 -1 |
| | 7 | 5 -2 |
| | | 20 -1 |
| | | 23 -2 |
| | 12 | 20 -1 |
| | 21 | 43 -1 |
| 26347-040002 | 7 | 18 |
| 26347-060002 | 7 | 19 |

| Parts No. | Fig. No. | Ref. No. |
|--------------|----------|----------|
| 26366-060002 | 4 | 41 |
| | 5 | 47 |
| 26366-080002 | 2 | 22 |
| | 7 | 5 -1 |
| | | 20 |
| | | 23 -1 |
| | 12 | 20 |
| | | 46 |
| | 14 | 83 |
| | 20 | 24 |
| | 21 | 43 |
| 26367-120002 | 3 | 11 |
| 26450-060252 | 10 | 15 |
| 26557-040352 | 7 | 21 |
| 26657-100002 | 17 | 27 |
| 26687-120002 | 14 | 91 |
| 26716-050002 | 21 | 32 |
| | | 48 |
| 26716-060002 | 13 | 96 |
| 26716-100002 | 12 | 21 |
| 26716-120002 | 8 | 17 |
| 26756-050002 | 17 | 3 |
| 26756-060002 | 14 | 81 |
| 26756-080002 | 21 | 49 |
| 26756-100002 | 12 | 22 |
| 26776-120002 | 14 | 82 |
| 26921-050122 | 17 | 21 |
| 27231-500000 | 1 | 8 |
| 27241-120000 | 1 | 9 |
| 27241-220000 | 5 | 19 |
| 27241-300000 | 1 | 10 |
| 27241-400000 | 4 | 11 |
| | 5 | 20 |
| 27310-070001 | 4 | 16 |
| | 5 | 25 |
| 719810-01500 | 2 | 1 |
| 719810-01650 | 3 | 26 |
| 719810-11520 | 4 | 42 |
| | 5 | 48 |
| 719810-11650 | 4 | 32 |
| | 5 | 37 |
| 719810-11660 | 4 | 32 -1 |
| | | 33 |
| 719810-23100 | 9 | 37 |
| 719818-11700 | 5 | 7 |
| 719818-53100 | 15 | 2 |
| 719822-01560 | 1 | 1 |
| 719822-51310 | 13 | 3 A |
| 719822-51370 | 13 | 1 |
| 719822-51400 | 13 | 3 |

| Parts No. | Fig. No. | Ref. No. |
|--------------|----------|----------|
| 719822-92600 | 22 | 1 |
| 719822-92610 | 22 | 2 |
| 719989-51310 | 13 | 2 |
| 729102-53100 | 15 | 3 |
| 729500-53200 | 15 | 1 |
| 933110-00100 | 21 | 33 |
| 933110-00301 | 21 | 35 |
| 977770-01212 | 2 | 32 |
| | 3 | 31 |
| | 22 | 33 |
| X0280210230 | 18 | 5 |
| | 19 | 11 |
| X0280630011 | 18 | 3 |
| X0280992761 | 18 | 4 |
| X0281003751 | 18 | 13 |
| X0282001531 | 18 | 14 |
| X0283060061 | 18 | 17 |
| | 19 | 2 |
| X0283270140 | 18 | 6 |
| | 19 | 12 |
| X0283711420 | 18 | 18 |
| X0283712350 | 18 | 7 |
| X0283810040 | 18 | 8 |
| X0284004910 | 18 | 19 |
| X0285040631 | 18 | 20 |
| X0285100460 | 18 | 21 |
| X0289030010 | 19 | 3 |
| X0534006460 | 18 | 23 |
| X0534040320 | 18 | 24 |
| X0534490120 | 18 | 25 |
| | | 26 |
| X0534490230 | 18 | 27 |
| | | 28 |
| X0535050620 | 18 | 29 |
| X0535130241 | 18 | 30 |
| X0535130320 | 18 | 31 |
| X0536600401 | 18 | 32 |
| X2411365340 | 12 | 5 A |
| X9019008651 | 18 | 42 |
| X9025808001 | 18 | 43 |
| X9151005141 | 18 | 33 |
| X9490071810 | 18 | 44 |
| X9490071970 | 18 | 45 |
| X9490170900 | 18 | 34 |
| | | 35 |
| X9490423330 | 18 | 46 |
| X9490441303 | 18 | 36 |
| X9490441312 | 18 | 37 |
| X9490502820 | 18 | 38 |
| | | 39 |



Parts No. Index

| Parts No. | Fig. No. | Ref. No. |
|-------------|----------|----------|
| X9490561370 | 18 | 47 |
| | 19 | 4 |
| X9490721080 | 18 | 9 |
| X9491001360 | 18 | 15 |
| X9491001860 | 18 | 16 |
| X9491200240 | 18 | 48 |
| | 19 | 5 |
| X9491402100 | 18 | 40 |
| | | 41 |
| X9491703371 | 18 | 10 |
| | 19 | 13 |
| X9491703380 | 18 | 49 |
| X9491704260 | 18 | 11 |
| X9491730461 | 18 | 22 |
| | 19 | 26 |

| Parts No. | Fig. No. | Ref. No. |
|-----------|----------|----------|
|-----------|----------|----------|

| Parts No. | Fig. No. | Ref. No. |
|-----------|----------|----------|
|-----------|----------|----------|

| Parts No. | Fig. No. | Ref. No. |
|-----------|----------|----------|
|-----------|----------|----------|